

R3G310-RR12-P1

EC centrifugal fan - RadiCal

backward curved, single inlet

for railway applications



R3G310-RR12-P1 ebmpapst Datasheet

sales@fansco.com

www.fansco.com

Limited partnership · Headquarters Mulfingen
County court Stuttgart · HRA 590344

General partner Elektrobau Mulfingen GmbH · Headquarters Mulfingen
County court Stuttgart · HRB 590142

Nominal data

Type	R3G310-RR12-P1	
Motor	M3G084-DF	
Nominal voltage	VDC	110
Nominal voltage range	VDC	77 .. 138
Type of data definition		ml
Speed (rpm)	min ⁻¹	2260
Power input	W	465
Current draw	A	4.2
Min. ambient temperature	°C	-40
Max. ambient temperature	°C	60

ml = Max. load · me = Max. efficiency · fa = Running at free air · cs = Customer specs · cu = Customer unit
Subject to alterations

Data in accordance with ecodesign regulation EU 327/2011 (EN 17166)

		Actual	Request 2015			
01 Overall efficiency η_{es}	%	65.9	48	09 Power input P_e	kW	0.46
02 Measurement category		A		09 Air flow q_v	m ³ /h	2105
03 Efficiency category		Static		09 Pressure increase p_{fs}	Pa	472
04 Efficiency grade N		79.9	62	10 Speed (rpm) n	min ⁻¹	2260
05 Variable speed drive		Yes		11 Specific ratio*		1.00

Data definition with optimum efficiency.

* Specific ratio = $1 + p_{fs} / 100\,000\text{ Pa}$

LU-160428

The indicated efficiency values for obtaining conformity with the Ecodesign Directive EU 327/2011 were achieved with defined air conduction components (e.g. inlet nozzles). The dimensions are to be requested from ebm-papst. If other air guide geometries are used on the installation side, the ebm-papst evaluation loses its validity/conformity must be confirmed again. The product does not fall within the scope of Regulation (EU) 2019/1781 due to the exception specified in Article 2(2a) (motors completely integrated into a product).



Technical features

Mass	4.6 kg
Size	310 mm
Motor size	84
Surface of rotor	Coated in black
Material of electronics housing	Die-cast aluminium
Material of impeller	PA UL94 V0 plastic
Number of blades	6
Direction of rotation	Clockwise, seen on rotor
Type of protection	IP55
Insulation class	"F"
Humidity (F) / environmental protection class (H)	H3
Max. permissible ambient motor temp. (transp./ storage)	+80 °C
Min. permissible ambient motor temp. (transp./storage)	-40 °C
Mounting position	Shaft horizontal or rotor on bottom; rotor on top on request
Condensation drainage holes	Rotor-side
Operation mode	S1
Motor bearing	Ball bearing; (sealed)
Technical features	<ul style="list-style-type: none"> - Output 10 VDC, max. 10 mA - Operation and alarm display - Alarm relay - Integrated PID controller - Run monitoring - Output limit - Motor current limit - RS485 MODBUS RTU - Soft start -Maximum EEPROM write cycles 100,000 - Control input 0-10 VDC / PWM - Control interface with SELV potential safely disconnected from the mains - Overvoltage detection - Over-temperature protected electronics / motor - Line undervoltage detection
EMC directives	According to EN 50121-3-2
Motor protection	Thermal overload protector (TOP) wired internally
Cable exit	Lateral
Safety classification	<p>I; If a protective earth is connected by the customer</p> <p>This component to be built-in can have several local protection class ratings. The specification refers to the basic design of this component.</p> <p>The final protection class is based on the intended installation and connection of the component.</p>
Product conforming to standard	EN 15085-1, CPC3; EN 45545-2, HL3; EN 50155; EN 61373, Cat. 1B; CE
Approval	EAC
Remark	<p>If voltage (e.g. 230 VAC) is passed through the alarm relay, the SELV signal wires lose their increased insulation, meaning they only have basic insulation</p> <p>The SELV property (increased insulation) is not lost when voltages of up to 110 VDC are passed through the alarm relay.</p>

EC centrifugal fan - RadiCal

backward curved, single inlet
for railway applications

Product drawing

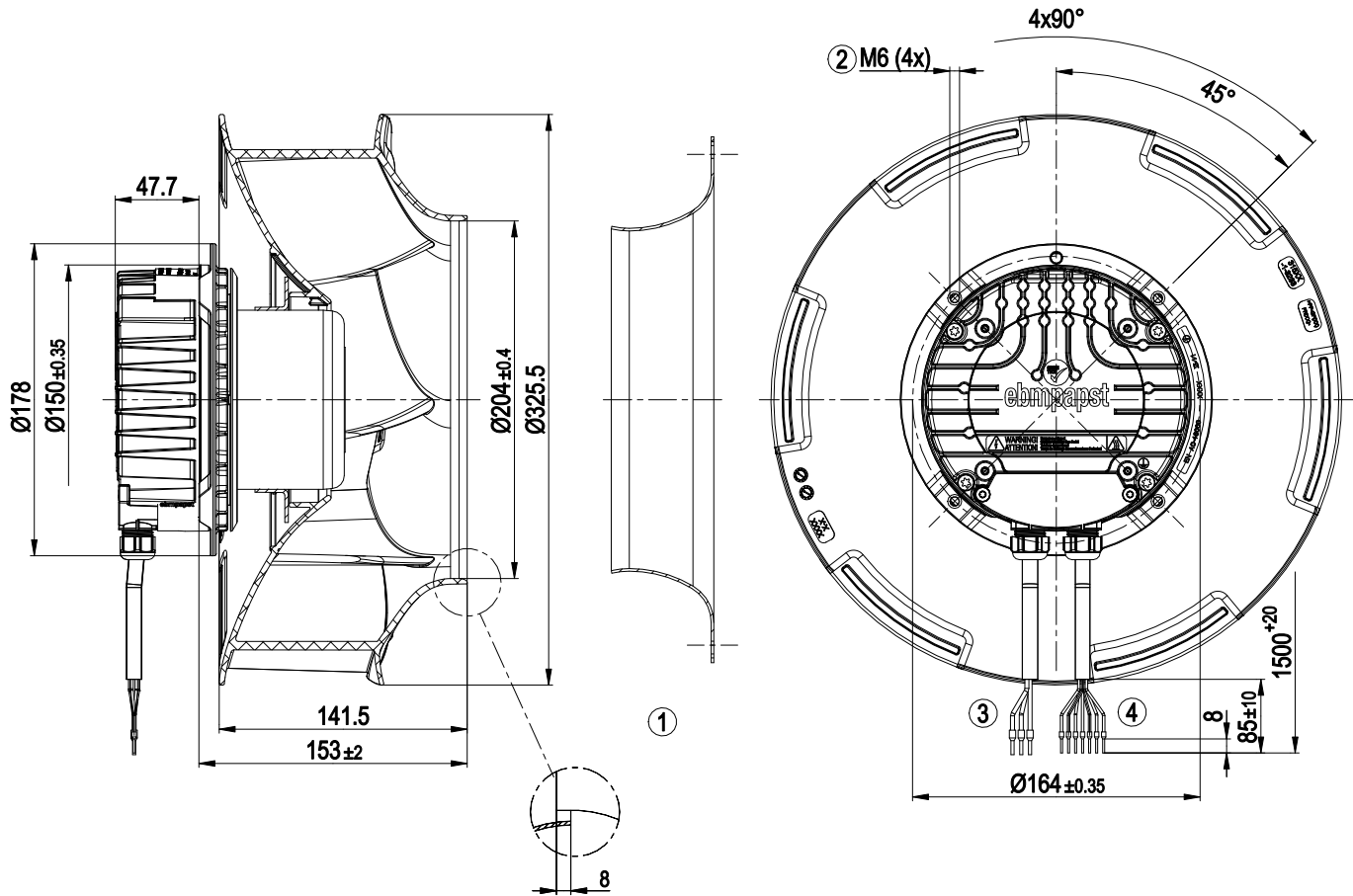

1	Accessory part: Inlet nozzle 31000-2-4013 not included in scope of delivery
2	Thread reach max. 16 mm
3	Connection line, halogen-free, railway application EN 45545, 4G 1.5 mm ² 3x core-end sleeve, 1x lead not brought out
4	Connection line, halogen-free, railway application EN 45545, 7x 0.5 mm ² 7x core-end sleeve



EC centrifugal fan - RadiCal

backward curved, single inlet

for railway applications

Accessory part

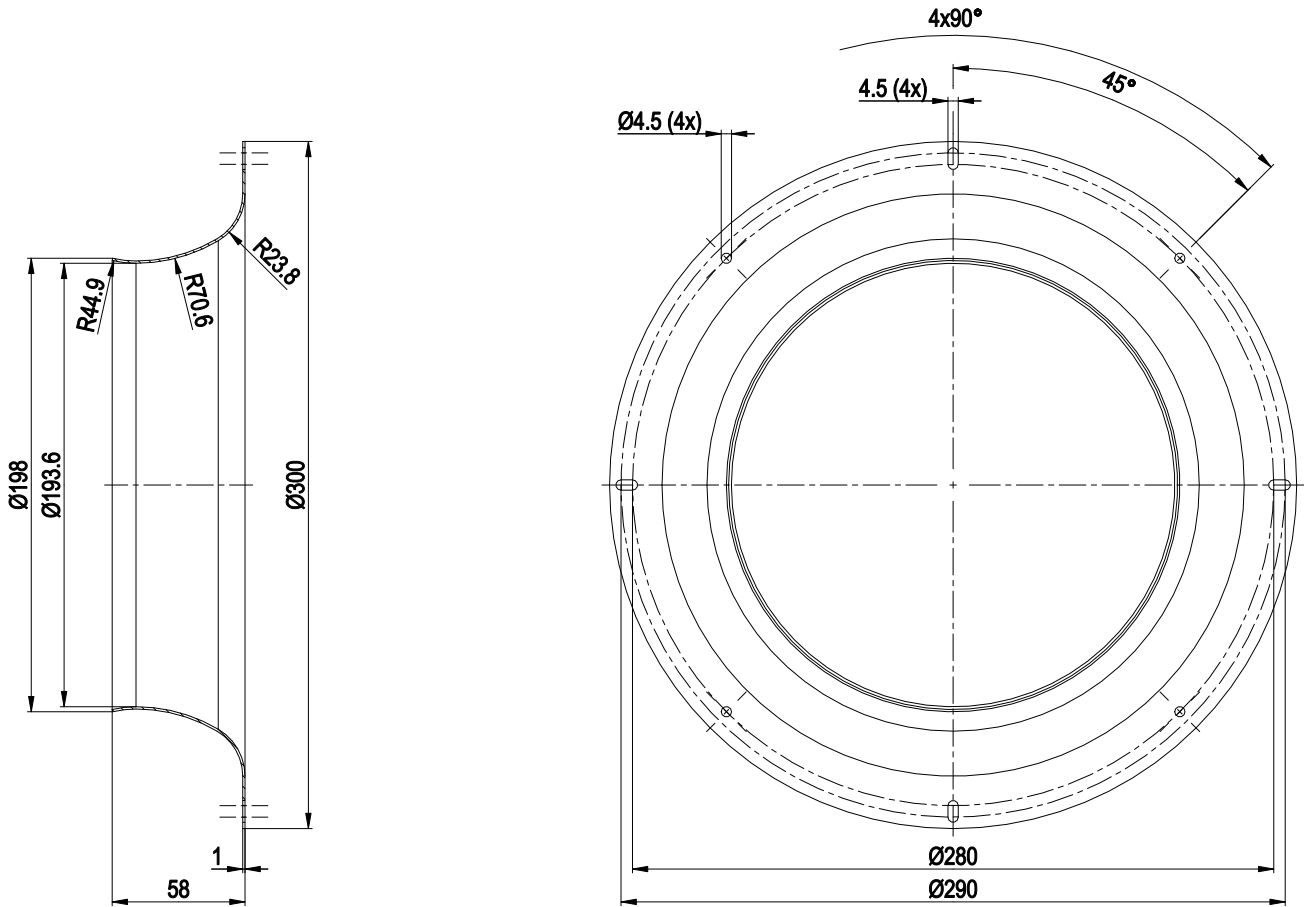

Inlet nozzle 31000-2-4013



EC centrifugal fan - RadiCal

backward curved, single inlet

for railway applications

Connection screen

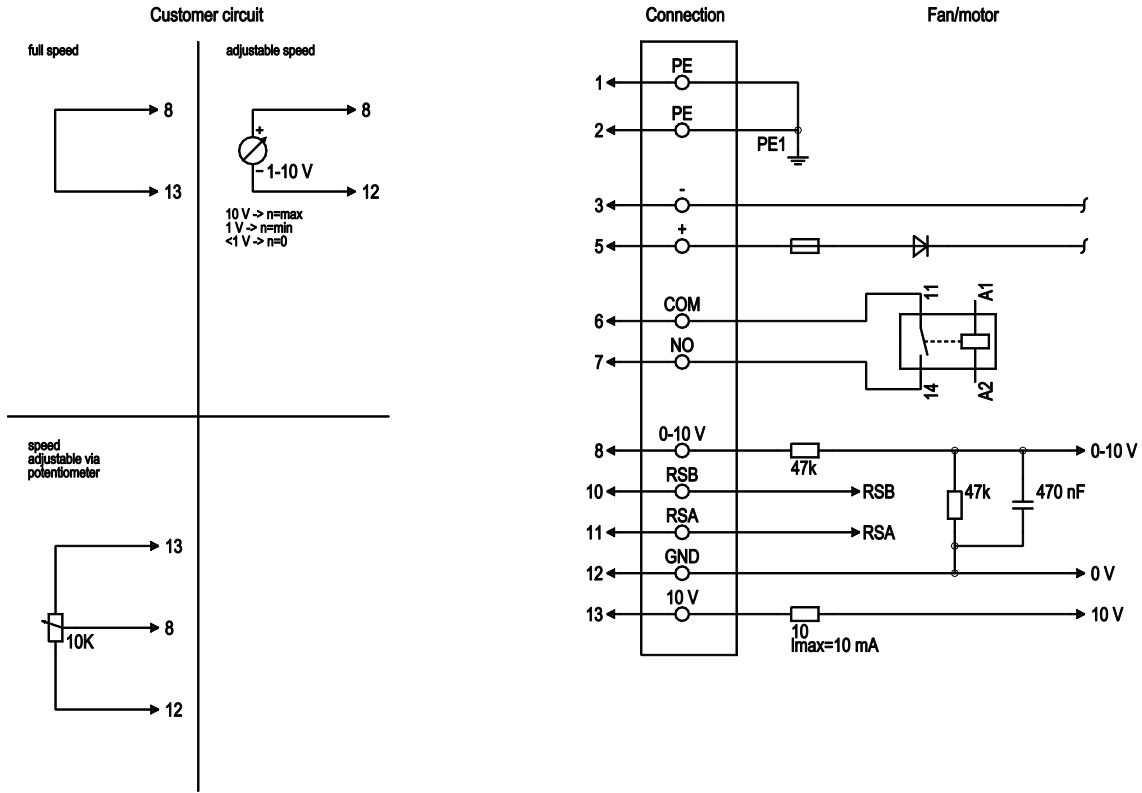

No.	Conn.	Designation	Colour	Function / assignment
1	1	PE	green/yellow	Protective earth
1	2	PE	-	not brought out via lead
1	3	-	black	Power supply, GND, see type plate for voltage range
1	5	+	brown	Power supply, see type plate for voltage range
2	6	COM	grey	Status relay, floating status contact, common connection, contact rating 250 VAC/ 30 VDC max. 2 A (AC1), min. 1 mA/5 VDC, reinforced insulation with respect to control interface, basic insulation on mains side in accordance with EN 50124-1
2	7	NO	orange	Status relay, floating status contact, make contact, contact rating 250 VAC/30 VDC max. 2 A (AC1), min. 1 mA/5 VDC, reinforced insulation with respect to control interface, basic insulation on mains side in accordance with EN 50124-1
2	8	0-10 V	yellow	Analogue input (set value) SELV, 0-10 V, R _i =100kΩ, parametrisable curve
2	10	RSB	brown	RS 485 interface for MODBUS, RSB; SELV, bus termination resistor provided by customer
2	11	RSA	white	RS 485 interface for MODBUS, RSA; SELV, bus termination resistor provided by customer
2	12	GND	blue	Reference ground for control interface; SELV
2	13	+10 V	red	Fixed voltage output 10 VDC, SELV, +10 V +/-3%, max. 10 mA, short-circuit-proof, power supply for external devices (e.g. potentiometers)



Charts: Air flow

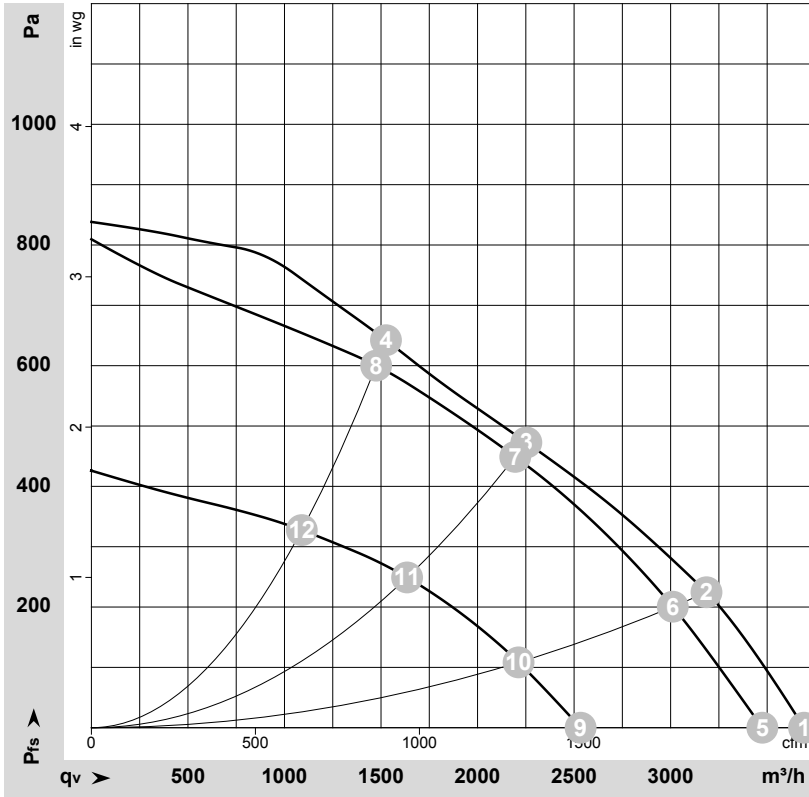

$\rho = 1.15 \text{ kg/m}^3 \pm 2 \%$

Measurement: LU-172392-1
 Measurement: LU-160428-1
 Measurement: LU-172391-1

Air performance measured as per ISO 5801 Installation category A. For detailed information on the measuring set-up, please contact ebm-papst. Suction-side noise levels: LwA measured as per ISO 13347 / LpA measured with 1m distance to fan axis. The values given are valid under the measuring conditions mentioned above and may vary according to the actual installation situation. With any deviation from the standard set-up, the specific values have to be checked and reviewed with the unit installed.

Measured values

	Conn.	U	n	P _{ed}	I	q _v	P _{fs}	q _v	P _{fs}
		V	min ⁻¹	W	A	m ³ /h	Pa	cfm	in. wg
1	Y	138	2505	436	3.16	3690	0	2170	0.00
2	Y	138	2440	513	3.71	3185	225	1875	0.90
3	Y	138	2325	513	3.72	2255	473	1325	1.90
4	Y	138	2370	512	3.71	1525	643	900	2.58
5	Y	110	2355	356	3.24	3475	0	2045	0.00
6	Y	110	2295	428	3.89	3010	200	1770	0.80
7	Y	110	2260	465	4.20	2195	450	1290	1.81
8	Y	110	2290	450	4.09	1475	600	870	2.41
9	Y	77	1735	152	1.97	2535	0	1490	0.00
10	Y	77	1705	180	2.34	2210	110	1300	0.44
11	Y	77	1690	198	2.58	1635	249	960	1.00
12	Y	77	1695	191	2.49	1090	328	640	1.32

Conn. = Connection · U = Supply voltage · n = Speed (rpm) · P_{ed} = Power input · I = Current draw · q_v = Air flow · P_{fs} = Pressure increase

