

R3G310-RP04-B1 ebmpapst Datasheet

sales@fansco.com

www.fansco.com

Limited partnership · Headquarters Muldingen

Amtsgericht (court of registration) Stuttgart · HRA 590344

General partner Elektrobau Muldingen GmbH · Headquarters Muldingen

Amtsgericht (court of registration) Stuttgart · HRB 590142



Nominal data

| | | |
|--------------------------|-------------------|------------|
| Type | R3G310-RP04-B1 | |
| Motor | M3G084-FA | |
| Phase | | 1~ |
| Nominal voltage | VAC | 230 |
| Nominal voltage range | VAC | 200 .. 277 |
| Frequency | Hz | 50/60 |
| Method of obtaining data | | ml |
| Speed (rpm) | min ⁻¹ | 2560 |
| Power consumption | W | 715 |
| Current draw | A | 3.2 |
| Min. ambient temperature | °C | -25 |
| Max. ambient temperature | °C | 40 |

ml = Max. load · me = Max. efficiency · fa = Free air · cs = Customer specification · ce = Customer equipment
Subject to change

Data according to ErP Directive

| | | Actual | Req. 2015 | | | |
|-----------------------------------|---|--------|-----------|-------------------------------|-------------------|------|
| 01 Overall efficiency η_{es} | % | 64.9 | 49.9 | 09 Power consumption P_{ed} | kW | 0.7 |
| 02 Measurement category | | A | | 09 Air flow q_v | m ³ /h | 2250 |
| 03 Efficiency category | | Static | | 09 Pressure increase p_{fs} | Pa | 670 |
| 04 Efficiency grade N | | 77 | 62 | 10 Speed (rpm) n | min ⁻¹ | 2565 |
| 05 Variable speed drive | | Yes | | 11 Specific ratio* | | 1.01 |

Data obtained at optimum efficiency level.

The ErP data is determined using a motor-impeller combination in a standardized measurement setup.

* Specific ratio = $1 + p_{fs} / 100\,000\text{ Pa}$

LU-138000



Technical description

| | |
|--|---|
| Weight | 5.8 kg |
| Fan size | 310 mm |
| Rotor surface | Painted black |
| Electronics housing material | Die-cast aluminum |
| Impeller material | PP plastic |
| Number of blades | 6 |
| Direction of rotation | Clockwise, viewed toward rotor |
| Degree of protection | IP54 |
| Insulation class | "B" |
| Moisture (F) / Environmental (H) protection class | F3-1 |
| Max. permitted ambient temp. for motor (transport/storage) | +80 °C |
| Min. permitted ambient temp. for motor (transport/storage) | -40 °C |
| Installation position | Shaft horizontal or rotor on top; rotor on bottom on request |
| Condensation drainage holes | None |
| Mode | S1 |
| Motor bearing | Ball bearing |
| Technical features | <ul style="list-style-type: none"> - Output 10 VDC, max. 10 mA - Output 20 VDC, max. 50 mA - Output for slave 0-10 V - Input for sensor 0-10 V or 4-20 mA - Alarm relay - Motor current limitation - PFC, active - RS-485 MODBUS-RTU - Soft start - Control input 0-10 VDC / PWM - Control interface with SELV potential safely disconnected from supply - Thermal overload protection for electronics/motor - Line undervoltage / phase failure detection |
| EMC immunity to interference | According to EN 61000-6-2 (industrial environment) |
| EMC circuit feedback | According to EN 61000-3-2/3 |
| EMC interference emission | According to EN 61000-6-3 (household environment) |
| Touch current according to IEC 60990 (measuring circuit Fig. 4, TN system) | <= 3.5 mA |
| Electrical hookup | Via terminal box |
| Motor protection | Thermal overload protector (TOP) internally connected |
| Protection class | I (if protective earth is connected by customer to the housing's connection point) |
| Conformity with standards | EN 61800-5-1; CE |
| Approval | EAC; CCC |

Product drawing

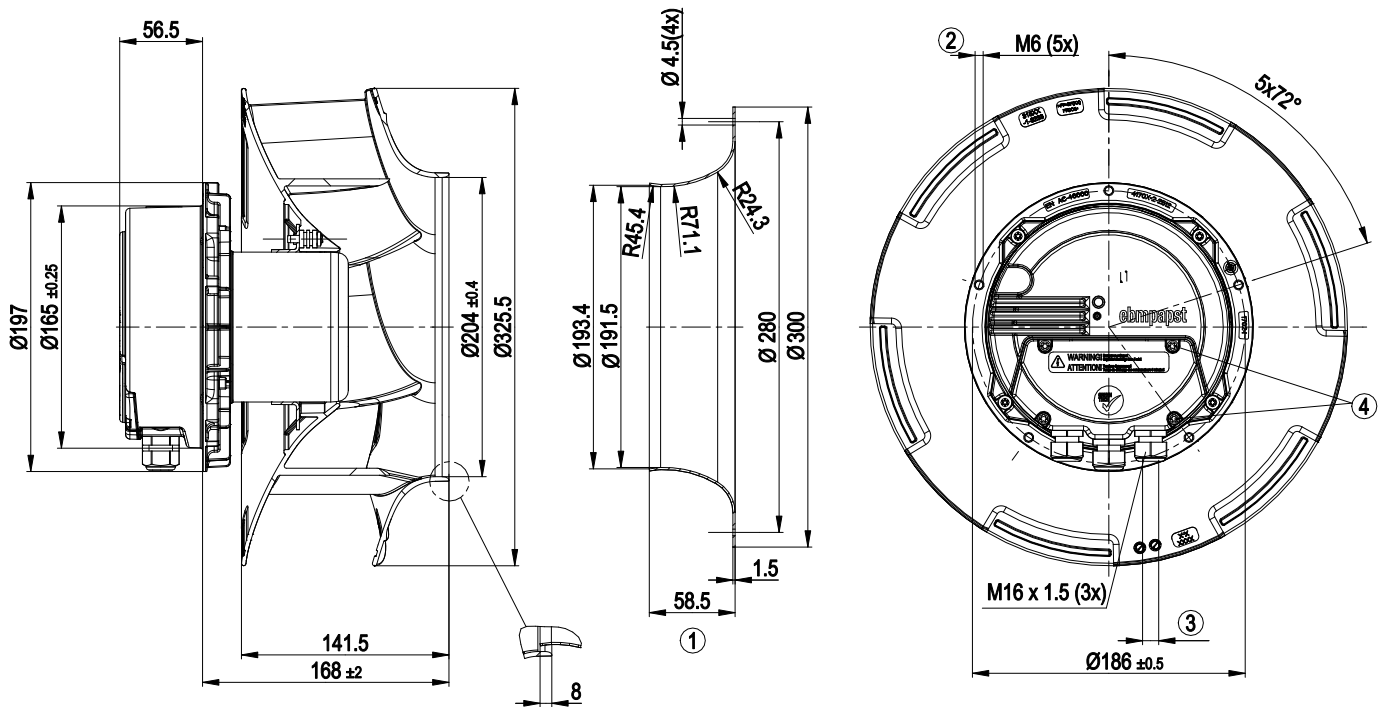

| | |
|---|--|
| 1 | Accessory part: Inlet ring 31000-2-4013 not included in scope of delivery. |
| 2 | Max. clearance for screw 16 mm |
| 3 | Cable diameter min. 4 mm, max. 10 mm, tightening torque 2.5 ± 0.4 Nm |
| 4 | Tightening torque 3.5 ± 0.5 Nm |



Connection diagram

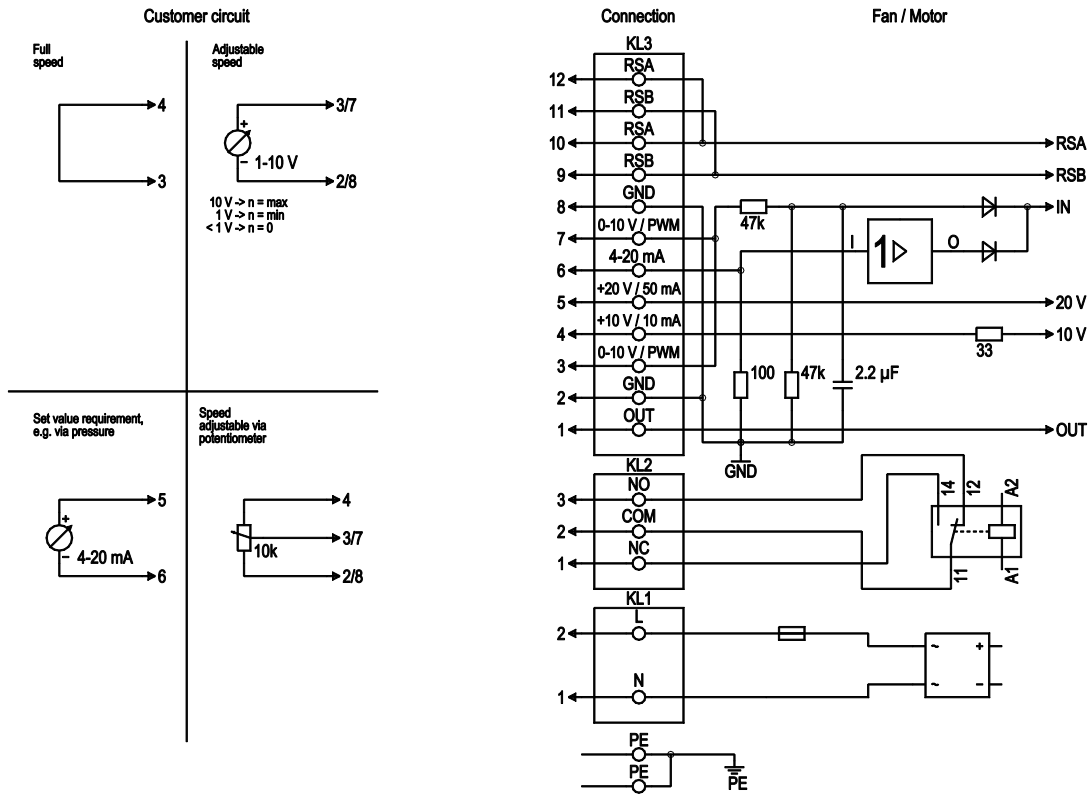

| No. | Conn. | Designation | Function/assignment |
|-----|--------|-------------|---|
| PE | - | PE | Protective earth terminal |
| KL1 | 1, 2 | N, L | Power supply 50/60 Hz |
| KL2 | 1 | NC | Floating status contact, break for failure |
| KL2 | 2 | COM | Floating status contact, changeover contact, common connection (2 A, max. 250 VAC, min. 10 mA, AC1) |
| KL2 | 3 | NO | Floating status contact, make for failure |
| KL3 | 1 | OUT | Analog output, 0-10 VDC, max. 3 mA, SELV output of current motor modulation level: 1 V corresponds to 10% modulation level. 10 V corresponds to 100% modulation level. |
| KL3 | 2, 8 | GND | Reference ground for control interface, SELV |
| KL3 | 3, 7 | 0-10 V | Control/current sensor value input 0-10 VDC, impedance 100 kΩ, use only as alternative to 4-20 mA input, SELV |
| KL3 | 4 | +10 V | Voltage output 10 VDC (+/- 3%), max. 10 mA, power supply for ext. devices (e.g. potentiometer), SELV |
| KL3 | 5 | +20 V | Voltage output 20 VDC (+25%/-10%), max. 50 mA power supply for ext. devices (e.g. sensors), SELV |
| KL3 | 6 | 4-20 mA | Control/current sensor value input 4-20 mA, impedance 100 Ω, use only as alternative to 0-10 V input, SELV |
| KL3 | 9, 11 | RSB | RS485 interface for MODBUS, RSB |
| KL3 | 10, 12 | RSA | RS485 interface for MODBUS, RSA |

Curves: Air performance 50 Hz

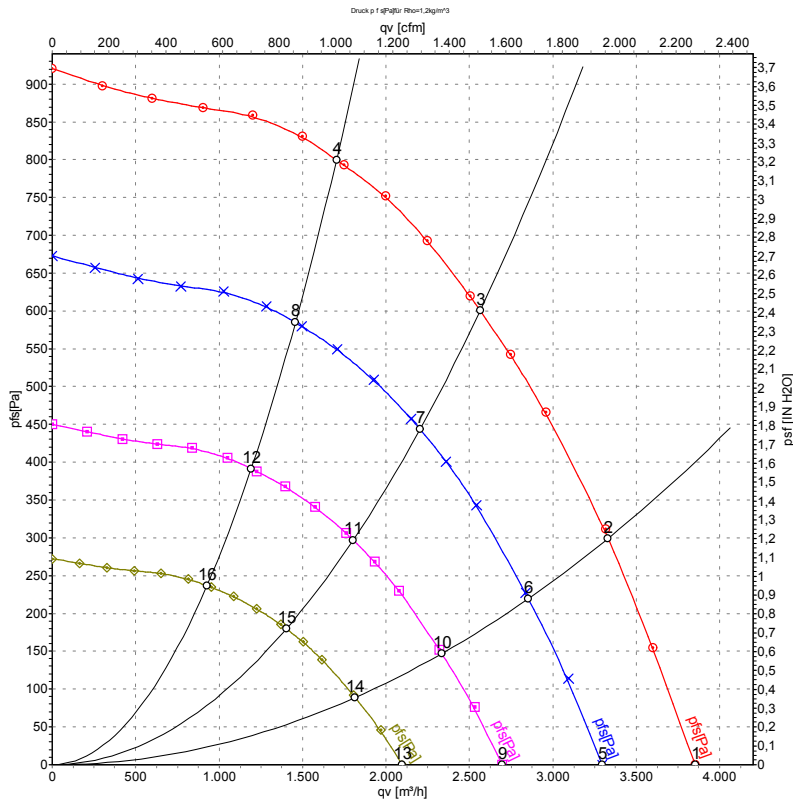

Measurement: LU-138000-1

Air performance measured according to ISO 5801 installation category A. For detailed information on the measurement setup, contact ebmpapst. Intake sound level: Sound power level according to ISO 13347 / sound pressure level measured at 1 m distance from fan axis. The values given are valid under the specified measuring conditions and may vary due to conditions of installation. For deviations from the standard configuration, the parameters have to be checked on the installed unit.

Measured values

| | U | f | n | P _{ed} | I | LpA _{in} | LwA _{in} | qv | p _{fs} | qv | p _{fs} |
|----|-----|----|-------------------|-----------------|------|-------------------|-------------------|------|-----------------|------|-----------------|
| | V | Hz | min ⁻¹ | W | A | dB(A) | dB(A) | m³/h | Pa | CFM | inH2O |
| 1 | 230 | 50 | 2560 | 488 | 2.21 | 74 | 82 | 3850 | 0 | 2265 | 0.00 |
| 2 | 230 | 50 | 2560 | 623 | 2.77 | 71 | 78 | 3330 | 300 | 1960 | 1.20 |
| 3 | 230 | 50 | 2560 | 715 | 3.20 | 65 | 72 | 2565 | 600 | 1510 | 2.41 |
| 4 | 230 | 50 | 2560 | 665 | 2.95 | 68 | 76 | 1705 | 800 | 1005 | 3.21 |
| 5 | 230 | 50 | 2200 | 305 | 1.38 | 70 | 78 | 3295 | 0 | 1940 | 0.00 |
| 6 | 230 | 50 | 2200 | 390 | 1.73 | 67 | 74 | 2850 | 221 | 1680 | 0.89 |
| 7 | 230 | 50 | 2200 | 453 | 2.01 | 61 | 68 | 2205 | 444 | 1295 | 1.78 |
| 8 | 230 | 50 | 2200 | 416 | 1.84 | 64 | 72 | 1455 | 585 | 860 | 2.35 |
| 9 | 230 | 50 | 1800 | 167 | 0.76 | 65 | 73 | 2695 | 0 | 1585 | 0.00 |
| 10 | 230 | 50 | 1800 | 214 | 0.95 | 62 | 69 | 2335 | 148 | 1375 | 0.59 |
| 11 | 230 | 50 | 1800 | 248 | 1.10 | 56 | 63 | 1805 | 297 | 1060 | 1.19 |
| 12 | 230 | 50 | 1800 | 228 | 1.01 | 59 | 67 | 1190 | 392 | 700 | 1.57 |
| 13 | 230 | 50 | 1400 | 79 | 0.36 | 59 | 66 | 2095 | 0 | 1235 | 0.00 |
| 14 | 230 | 50 | 1400 | 100 | 0.45 | 55 | 63 | 1815 | 89 | 1070 | 0.36 |
| 15 | 230 | 50 | 1400 | 117 | 0.52 | 50 | 57 | 1405 | 180 | 825 | 0.72 |
| 16 | 230 | 50 | 1400 | 107 | 0.48 | 53 | 60 | 925 | 237 | 545 | 0.95 |

U = Power supply · f = Frequency · n = Speed (rpm) · P_{ed} = Power consumption · I = Current draw · LpA_{in} = Sound pressure level intake side · LwA_{in} = Sound power level intake side
 qv = Air flow · p_{fs} = Pressure increase

