

R3G310-RO38-A8 ebmpapst Datasheet

sales@fansco.com

www.fansco.com

Limited partnership · Headquarters Mulfingen

Amtsgericht (court of registration) Stuttgart · HRA 590344

General partner Elektrobau Mulfingen GmbH · Headquarters Mulfingen

Amtsgericht (court of registration) Stuttgart · HRB 590142

Nominal data

Type	R3G310-RO38-A8	
Motor	M3G084-DF	
Phase		1~
Nominal voltage	VAC	230
Nominal voltage range	VAC	200 .. 277
Frequency	Hz	50/60
Method of obtaining data		ml
Speed (rpm)	min ⁻¹	2180
Power consumption	W	450
Current draw	A	2.0
Min. ambient temperature	°C	-25
Max. ambient temperature	°C	40

ml = Max. load · me = Max. efficiency · fa = Free air · cs = Customer specification · ce = Customer equipment
Subject to change

Data according to Commission Regulation (EU) 327/2011

		Actual	Req. 2015			
01 Overall efficiency η_{es}	%	62.5	47.9	09 Power consumption P_{ed}	kW	0.45
02 Measurement category		A		09 Air flow q_v	m ³ /h	1805
03 Efficiency category		Static		09 Pressure increase p_{fs}	Pa	509
04 Efficiency grade N		76.6	62	10 Speed (rpm) n	min ⁻¹	2175
05 Variable speed drive		Yes		11 Specific ratio [*]		1.01

Data obtained at optimum efficiency level.

The ErP data is determined using a motor-impeller combination in a standardized measurement setup.

^{*} Specific ratio = $1 + p_{fs} / 100\,000\text{ Pa}$

LU-136514



Technical description

Weight	4.7 kg
Fan size	310 mm
Rotor surface	Painted black
Electronics housing material	Die-cast aluminum
Impeller material	PP plastic
Number of blades	6
Direction of rotation	Clockwise, viewed toward rotor
Degree of protection	IP54
Insulation class	"B"
Moisture (F) / Environmental (H) protection class	F3-1
Max. permitted ambient temp. for motor (transport/storage)	+80 °C
Min. permitted ambient temp. for motor (transport/storage)	-40 °C
Installation position	Shaft horizontal or rotor on top; rotor on bottom on request
Condensation drainage holes	None
Mode	S1
Motor bearing	Ball bearing
Technical features	<ul style="list-style-type: none"> - Output 10 VDC, max. 10 mA - Tach output - Motor current limitation - PFC, active - Soft start - Control input 0-10 VDC / PWM - Control interface with SELV potential safely disconnected from the mains - Thermal overload protection for electronics/motor - Line undervoltage / phase failure detection
EMC immunity to interference	According to EN 61000-6-2 (industrial environment)
EMC circuit feedback	According to EN 61000-3-2/3
EMC interference emission	According to EN 61000-6-3 (household environment)
Touch current according to IEC 60990 (measuring circuit Fig. 4, TN system)	<= 3.5 mA
Motor protection	Thermal overload protector (TOP) internally connected
With cable	Variable
Protection class	I (with customer connection of protective earth)
Conformity with standards	EN 61800-5-1; CE
Approval	C22.2 No.77 + CAN/CSA-E60730-1; UL1004-3 +60730

Product drawing

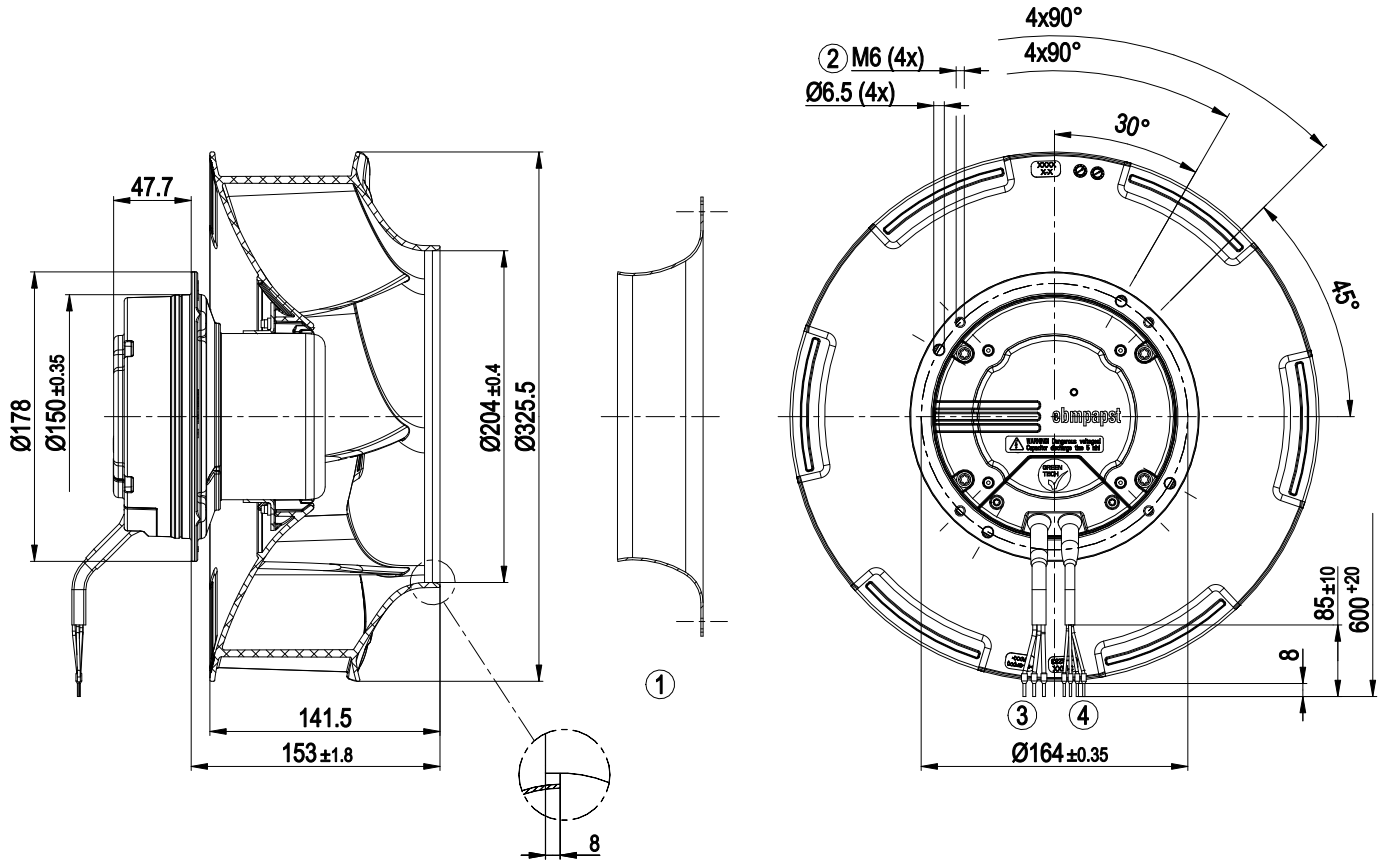

1	Accessory part: inlet ring 31000-2-4013 not included in scope of delivery
2	Max. clearance for screw 10 mm
3	Cable PVC AWG18, 3x crimped ferrules
4	Cable PVC AWG22, 4x crimped ferrules

Accessory part

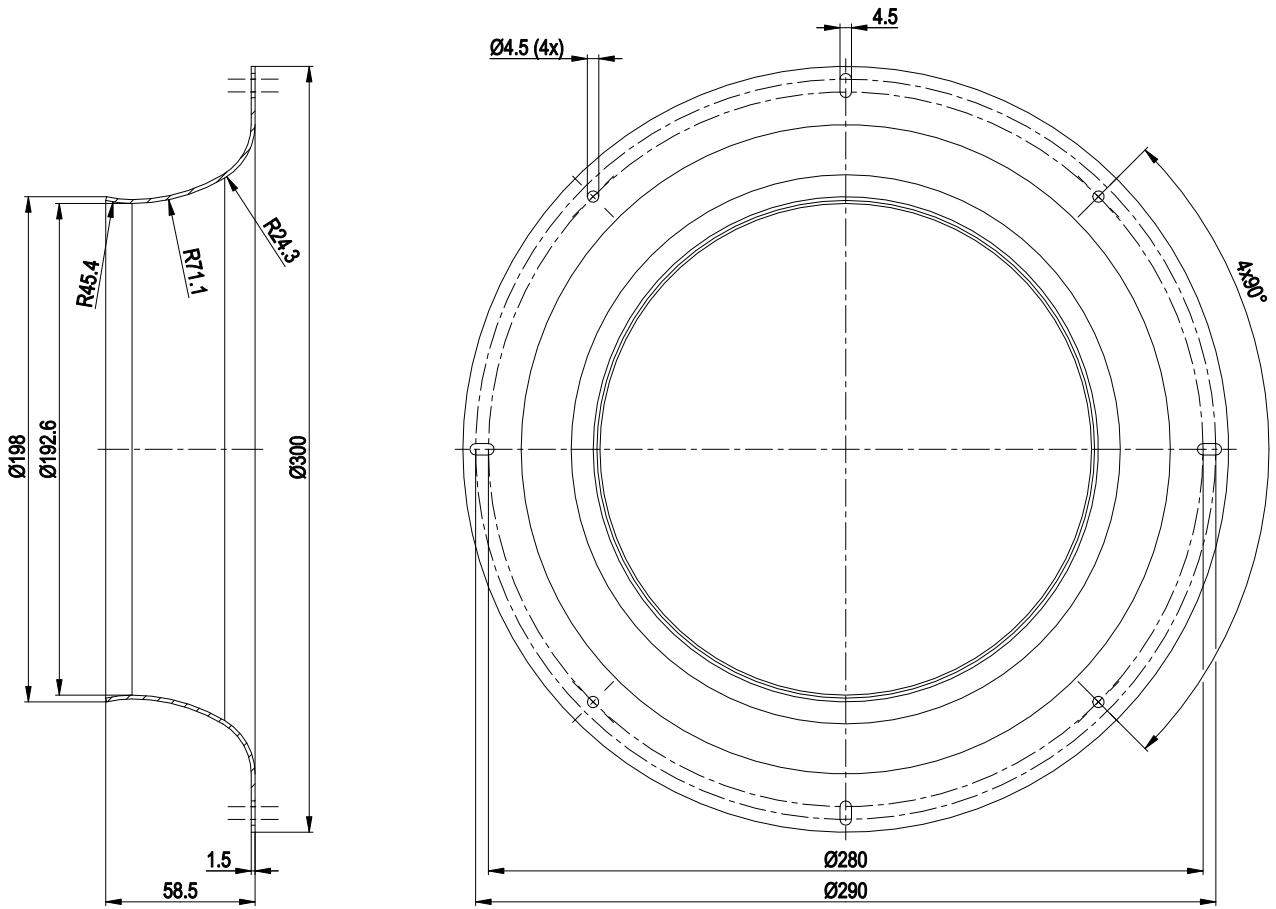

Accessory part: inlet ring 31000-2-4013 not included in scope of delivery

Connection diagram

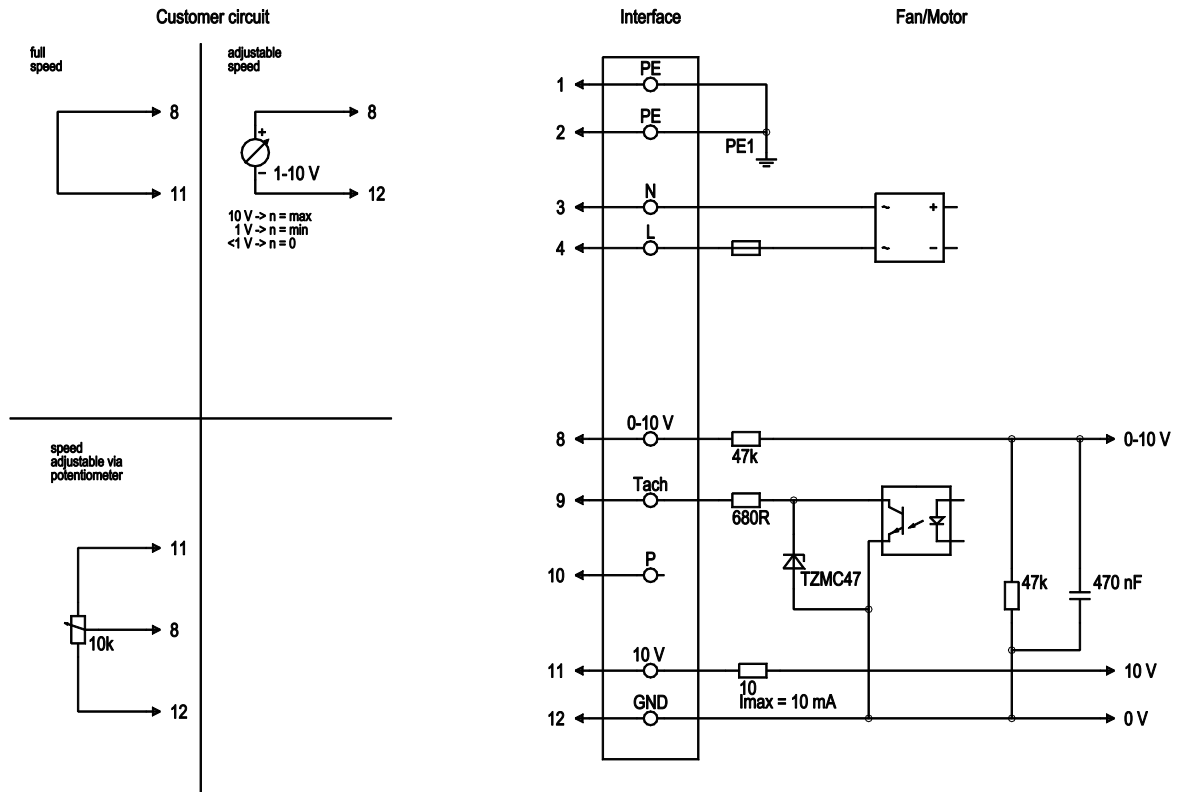

No.	Conn.	Designation	Color	Function/assignment
1	1, 2	PE	green/yellow	Protective earth
1	3	N	blue	Power supply, neutral conductor, 50/60 Hz
1	4	L	black	Power supply, phase, 50/60 Hz
2	8	0-10V	yellow	Control input, set value 0-10 VDC, impedance 100 kohms, SELV
2	9	Tach	white	Tach output: Open collector, 1 pulse per revolution, electrically isolated, Isink max. 10 mA
2	10	P		not used
2	11	10 VDC	red	Voltage output 10 VDC (+/- 3%), max. 10 mA, power supply for ext. devices (e.g. potentiometers), SELV
2	12	GND	blue	Reference ground for control interface, SELV



Curves: Air performance 50 Hz

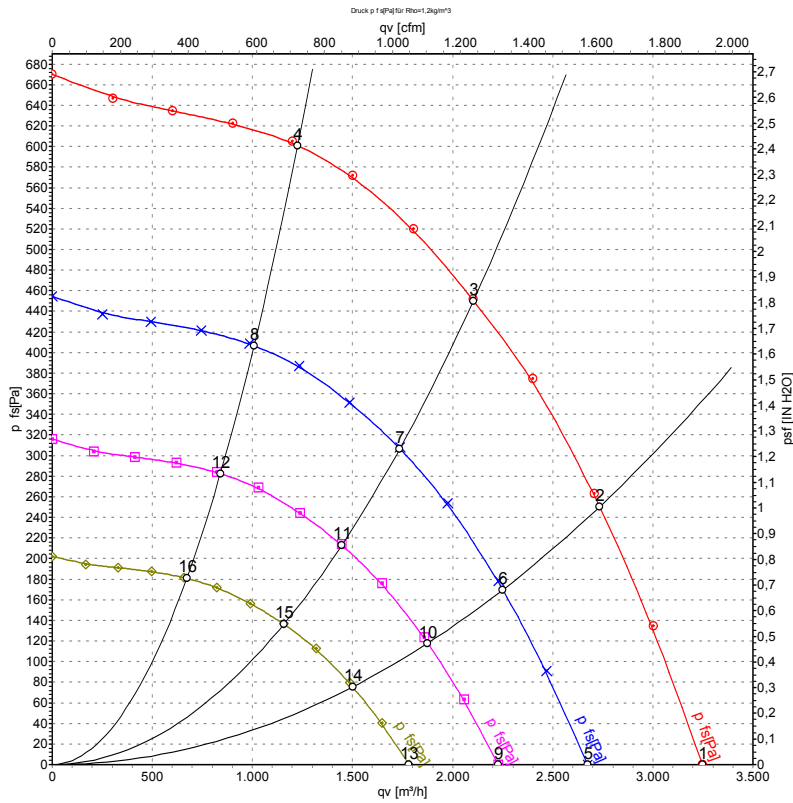

Measurement: LU-138323-1

Air performance measured according to ISO 5801 installation category A. For detailed information on the measurement setup, contact ebmpapst. Intake sound level: Sound power level according to ISO 13347 / sound pressure level measured at 1 m distance from fan axis. The values given are valid under the specified measuring conditions and may vary due to conditions of installation. For deviations from the standard configuration, the parameters have to be checked on the installed unit.

Measured values

	U	f	n	P _{ed}	I	LpA _{in}	LwA _{in}	q _v	p _{fs}	q _v	p _{fs}
	V	Hz	min ⁻¹	W	A	dB(A)	dB(A)	m ³ /h	Pa	cfm	inH ₂ O
1	230	50	2180	307	1.36	71	78	3250	0	1910	0.00
2	230	50	2180	404	1.77	66	73	2735	250	1610	1.00
3	230	50	2180	450	2.00	61	67	2105	450	1240	1.81
4	230	50	2180	399	1.75	64	72	1225	600	720	2.41
5	230	50	1800	171	0.76	66	73	2675	0	1575	0.00
6	230	50	1800	225	0.99	61	68	2250	171	1325	0.69
7	230	50	1800	254	1.11	56	63	1735	308	1020	1.24
8	230	50	1800	222	0.97	59	67	1010	407	595	1.63
9	230	50	1500	99	0.44	62	69	2230	0	1310	0.00
10	230	50	1500	130	0.57	57	63	1875	119	1105	0.48
11	230	50	1500	147	0.64	52	58	1445	214	850	0.86
12	230	50	1500	128	0.56	55	62	840	283	495	1.14
13	230	50	1200	51	0.23	56	63	1780	0	1050	0.00
14	230	50	1200	67	0.29	51	58	1500	76	885	0.31
15	230	50	1200	75	0.33	46	52	1155	137	680	0.55
16	230	50	1200	66	0.29	49	57	670	181	395	0.73

U = Power supply · f = Frequency · n = Speed (rpm) · P_{ed} = Power consumption · I = Current draw · LpA_{in} = Sound pressure level intake side · LwA_{in} = Sound power level intake side
 q_v = Air flow · p_{fs} = Pressure increase

