

R3G310-RO38-54 ebmpapst Datasheet  
 sales@fansco.com  
 www.fansco.com

Limited partnership · Headquarters Muldingen  
 Amtsgericht (court of registration) Stuttgart · HRA 590344  
 General partner Elektrobau Muldingen GmbH · Headquarters Muldingen  
 Amtsgericht (court of registration) Stuttgart · HRB 590142

## Nominal data

Type	R3G310-RO38-54	
Motor	M3G084-DF	
Phase		1~
Nominal voltage	VAC	230
Nominal voltage range	VAC	200 .. 277
Frequency	Hz	50/60
Method of obtaining data		ml
Speed (rpm)	min <sup>-1</sup>	2100
Power consumption	W	410
Current draw	A	1.8
Min. ambient temperature	°C	0
Max. ambient temperature	°C	40

ml = Max. load · me = Max. efficiency · fa = Free air · cs = Customer specification · ce = Customer equipment  
 Subject to change

## Data according to Commission Regulation (EU) 327/2011

		Actual	Req. 2015			
01 Overall efficiency $\eta_{es}$	%	62.8	47.3	09 Power consumption $P_{ed}$	kW	0.4
02 Measurement category		A		09 Air flow $q_v$	m <sup>3</sup> /h	1750
03 Efficiency category		Static		09 Pressure increase $p_{fs}$	Pa	466
04 Efficiency grade N		77.5	62	10 Speed (rpm) n	min <sup>-1</sup>	2110
05 Variable speed drive		Yes		11 Specific ratio*		1.00

Data obtained at optimum efficiency level.

The ErP data is determined using a motor-impeller combination in a standardized measurement setup.

\* Specific ratio =  $1 + p_{fs} / 100\,000\text{ Pa}$

LU-161250



## Technical description

Weight	4.6 kg
Size	310 mm
Motor size	84
Rotor surface	Painted black
Electronics housing material	Die-cast aluminum
Impeller material	PP plastic
Number of blades	6
Direction of rotation	Clockwise, viewed toward rotor
Degree of protection	IP20
Insulation class	"B"
Moisture (F) / Environmental (H) protection class	H0 - dry environment
Max. permitted ambient temp. for motor (transport/storage)	+80 °C
Min. permitted ambient temp. for motor (transport/storage)	-40 °C
Installation position	Shaft horizontal or rotor on top; rotor on bottom on request
Condensation drainage holes	None
Mode	S1
Motor bearing	Ball bearing
Technical features	<ul style="list-style-type: none"> <li>- Operation and alarm display with LED</li> <li>- Integrated PID controller</li> <li>- Motor current limitation</li> <li>- PFC, active</li> <li>- RS485 ebmBUS with DCI function</li> <li>- Soft start</li> <li>- Control interface with SELV potential safely disconnected from the mains</li> <li>- Thermal overload protection for electronics/motor</li> <li>- Line undervoltage / phase failure detection</li> </ul>
EMC immunity to interference	According to EN 61000-6-2 (industrial environment)
EMC circuit feedback	According to EN 61000-3-2/3
EMC interference emission	According to EN 61000-6-4 (industrial environment)
Touch current according to IEC 60990 (measuring circuit Fig. 4, TN system)	<= 3.5 mA
Electrical hookup	Connector with cable
Motor protection	Thermal overload protector (TOP) internally connected
With cable	Variable
Protection class	I (with customer connection of protective earth)
Conformity with standards	EN 61800-5-1; CE
Approval	EAC; UL 1004-3 + 60730-1; CSA C22.2 No. 77 + CAN/CSA-E60730-1

Product drawing

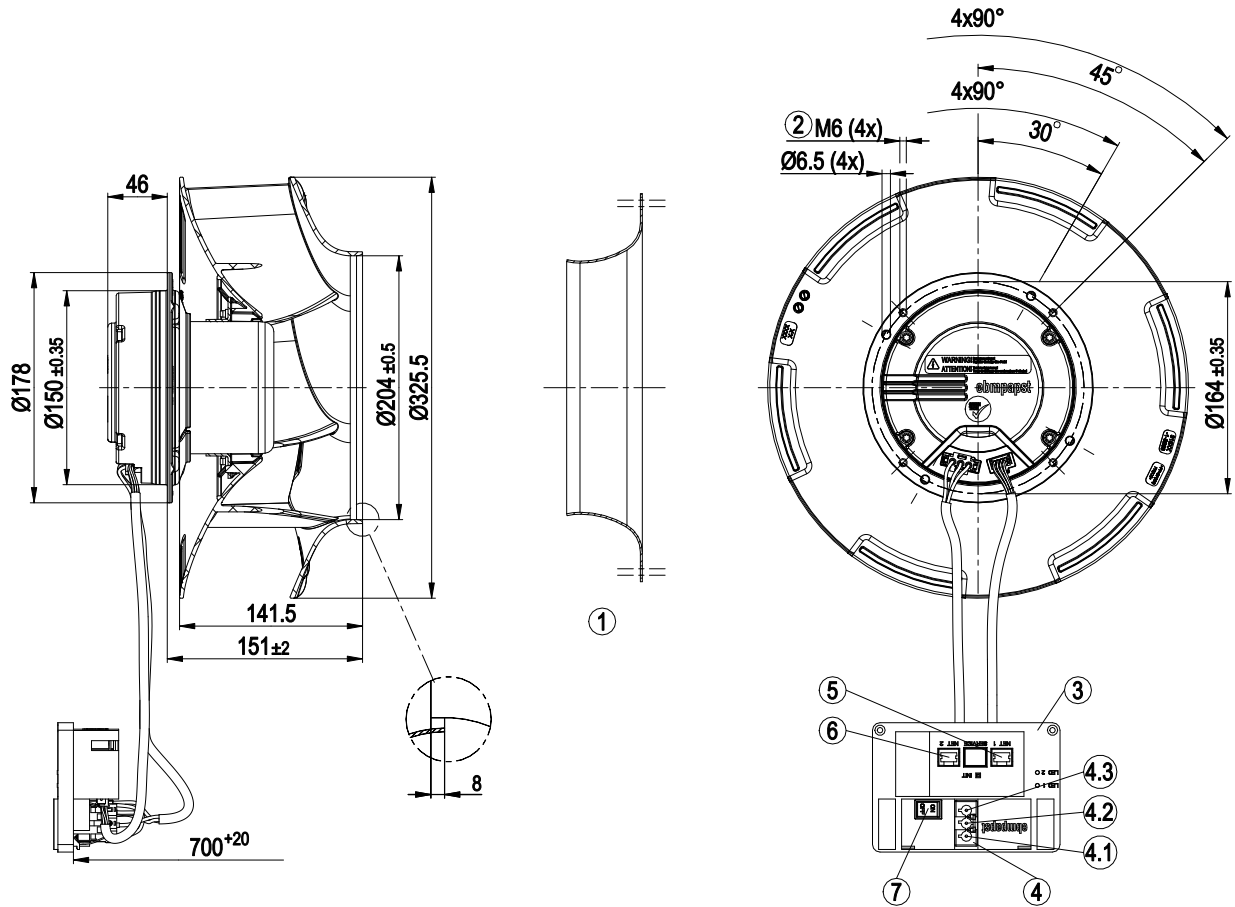

1	Accessory part: inlet ring 31000-2-4013 not included in scope of delivery
2	Max. clearance for screw 10 mm
3	Terminal box
4	Connector housing 3-pole GST18/3 Wieland 92.032.9058.1
4.1	N
4.2	PE
4.3	L
5	8-pole connector housing TE 100616-2
6	8-pole connector housing TE 100616-2
7	Switch, ARCOLECTRIC SWITCHES P L C (no. H8550VBACF) As-delivered condition end customer switch set to "OFF"



## Accessory part

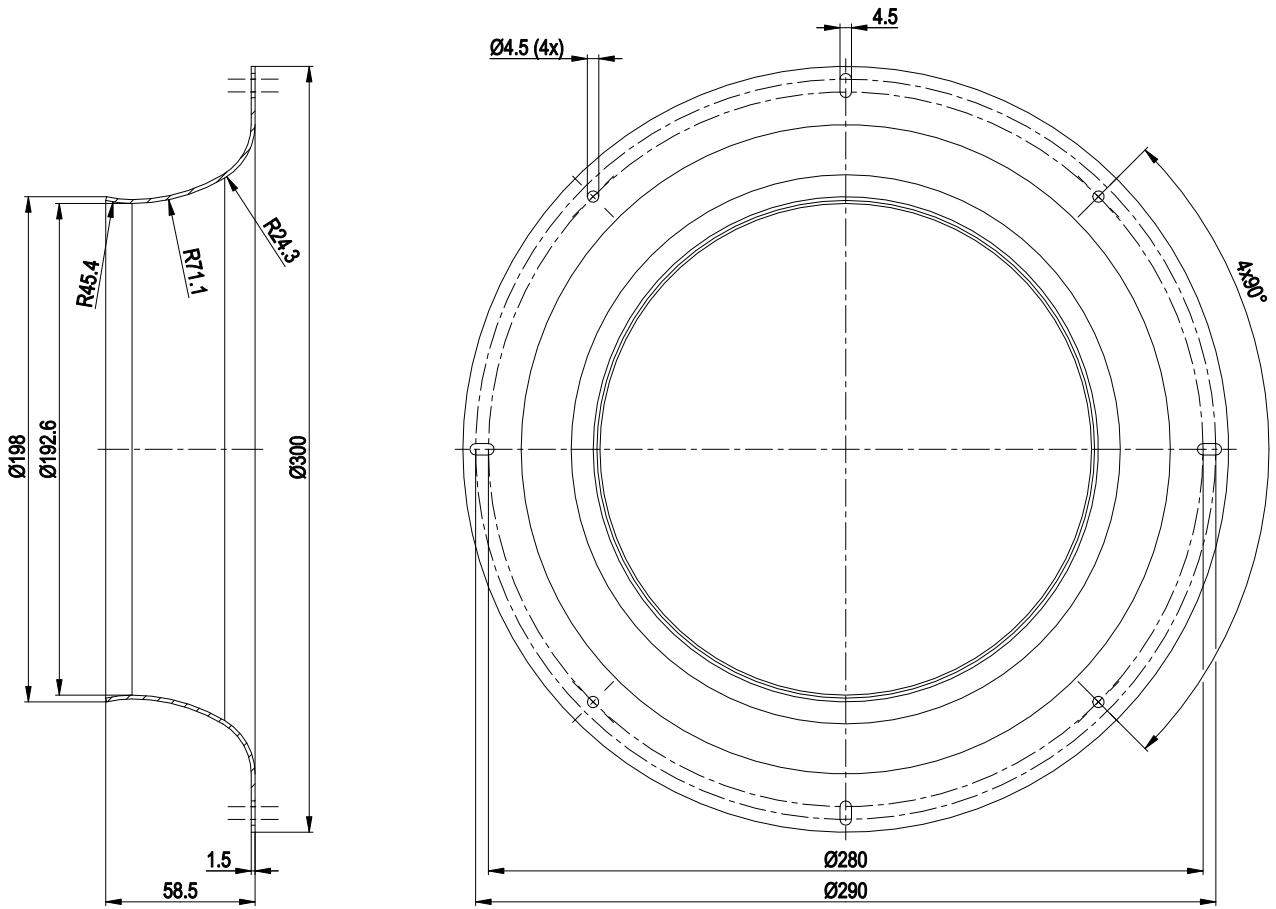

Accessory part: inlet ring 31000-2-4013 not included in scope of delivery

## Connection diagram

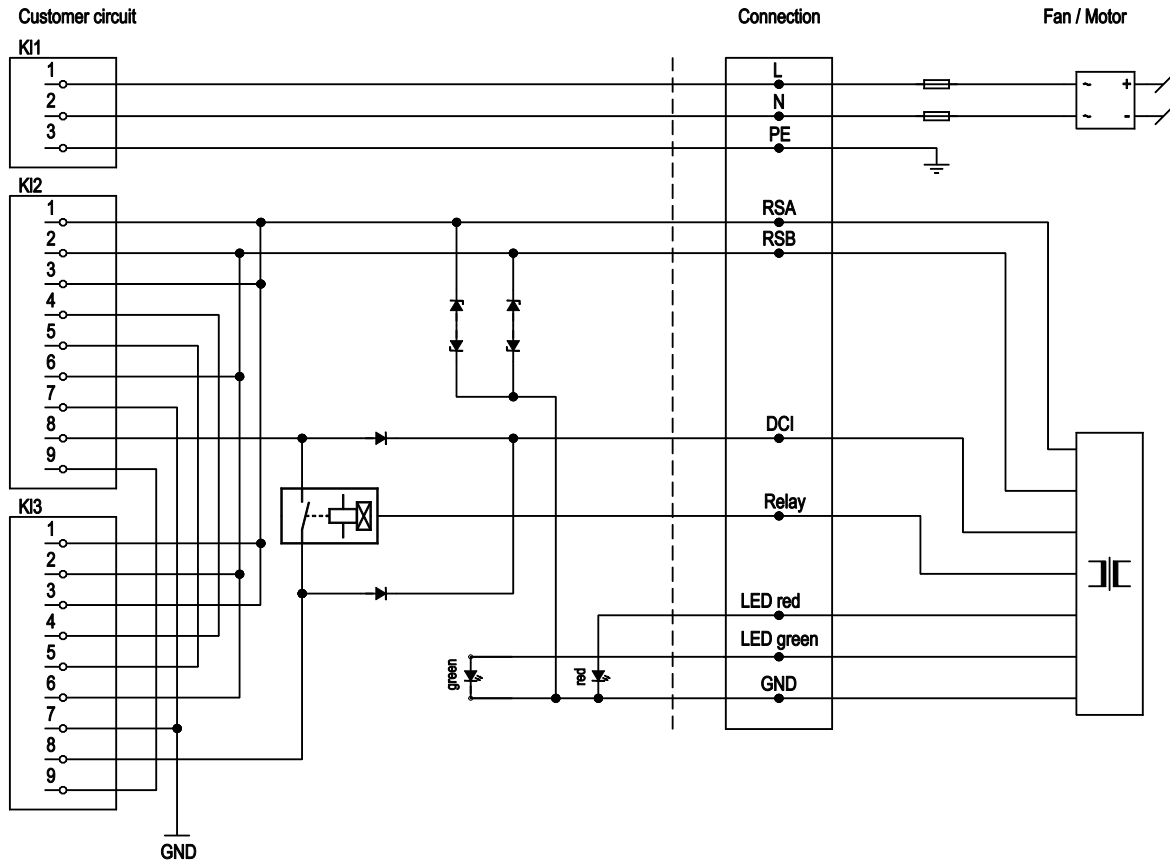

### LED1 / LED2

Status	Priority	Address S/N	Speed	green LED	red LED
Malfunction	1	S/N any	any	off	flashing 1 Hz
Flashing	2	S/N = 1/1	any	flashing 10 Hz	on
Flashing	2	S/N < 1	any	flashing 10 Hz	off
after set value change	3	S/N = 1/1	any	flashing 3 times at 2.5 Hz	on
after set value change	3	S/N < 1	any	flashing 3 times at 2.5 Hz	off
Fan speed 0	4	S/N = 1/1	n = 0	flashing 1 Hz	on
Fan speed 0	4	S/N < 1	n = 0	flashing 1 Hz	off
Fan speed > 0	4	S/N = 1/1	n > 0	off	on
Fan speed > 0	4	S/N < 1	n > 0	on	off

No.	Conn.	Designation	Function/assignment
KL1	1	L	Power supply, phase, 50/60 Hz
KL1	2	N	Power supply, neutral conductor, 50/60 Hz
KL1	3	PE	Protective earth
KL2/KL3	1	RSA	RS485 interface for ebmBUS, RSA
KL2/KL3	2	RSB	RS485 interface for ebmBUS, RSB
KL2/KL3	3	RSA	RS485 interface for ebmBUS, RSA
KL2/KL3	4	-	Bridge KL2-KL3
KL2/KL3	5	-	Bridge KL2-KL3
KL2/KL3	6	RSB	RS485 interface for ebmBUS, RSB
KL2/KL3	7	GND	Reference ground
KL2/KL3	8	DCI	Daisy chain signal
KL2/KL3	9	Schirm	Shield for RJ45 CAT5 wire (not used)



## Curves: Air performance 50 Hz

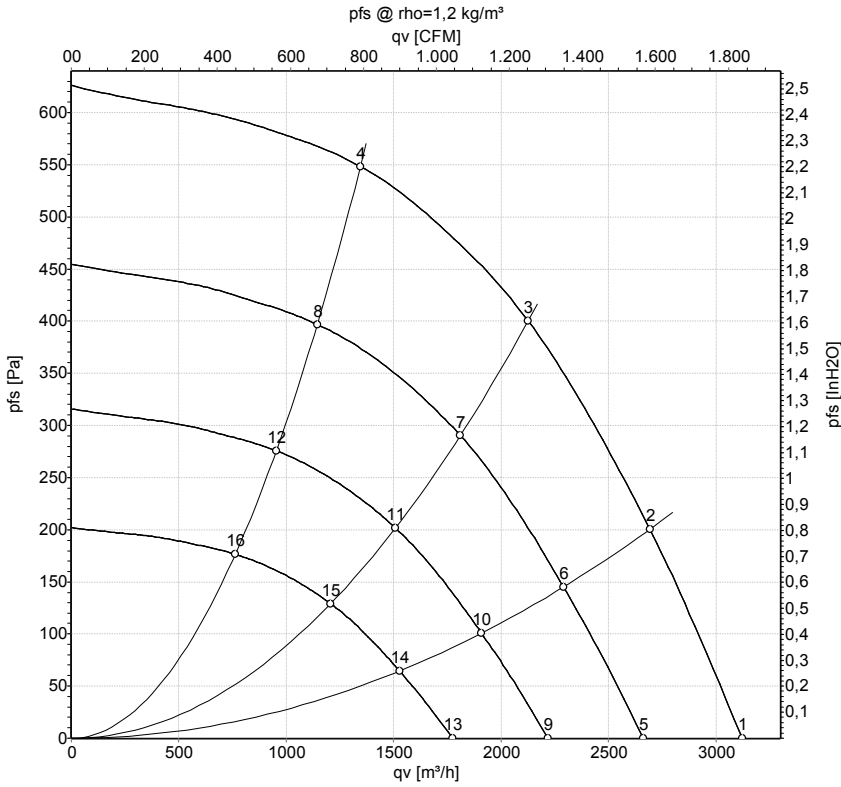

Measurement: LU-161250-1

Air performance measured according to ISO 5801 installation category A. For detailed information on the measurement setup, contact ebm-papst. Intake sound level: Sound power level according to ISO 13347 / sound pressure level measured at 1 m distance from fan axis. The values given are valid under the specified measuring conditions and may vary due to conditions of installation. For deviations from the standard configuration, the parameters have to be checked on the installed unit.

## Measured values

	U	f	n	P <sub>ed</sub>	I	q <sub>v</sub>	P <sub>fs</sub>	q <sub>v</sub>	P <sub>fs</sub>
	V	Hz	min <sup>-1</sup>	W	A	m <sup>3</sup> /h	Pa	cfm	in. wg
1	230	50	2100	281	1.23	3120	0	1840	0.00
2	230	50	2100	359	1.57	2695	200	1585	0.80
3	230	50	2100	410	1.80	2125	400	1250	1.61
4	230	50	2100	376	1.64	1345	550	790	2.21
5	230	50	1800	174	0.76	2660	0	1565	0.00
6	230	50	1800	221	0.97	2290	145	1350	0.58
7	230	50	1800	254	1.11	1810	290	1065	1.16
8	230	50	1800	232	1.01	1145	397	675	1.59
9	230	50	1500	101	0.44	2220	0	1305	0.00
10	230	50	1500	128	0.56	1910	101	1125	0.41
11	230	50	1500	147	0.64	1510	202	890	0.81
12	230	50	1500	134	0.59	955	276	560	1.11
13	230	50	1200	52	0.23	1775	0	1045	0.00
14	230	50	1200	65	0.29	1525	65	900	0.26
15	230	50	1200	75	0.33	1205	129	710	0.52
16	230	50	1200	69	0.30	765	176	450	0.71

U = Voltage · f = Frequency · n = Speed (rpm) · P<sub>ed</sub> = Power consumption · I = Current draw · q<sub>v</sub> = Air flow · p<sub>s</sub> = Pressure increase

