

R3G310-RO36-81 ebmpapst Datasheet

sales@fansco.com

www.fansco.com

**Nominal data**

<b>Type</b>	<b>R3G310-RO36-81</b>	
<b>Motor</b>	<b>M3G084-DF</b>	
Phase		1~
Nominal voltage	VAC	115
Nominal voltage range	VAC	100 .. 130
Frequency	Hz	50/60
Type of data definition		ml
Speed	min <sup>-1</sup>	2010
Power input	W	345
Current draw	A	3.0
Min. ambient temperature	°C	-25
Max. ambient temperature	°C	50

ml = Max. load · me = Max. efficiency · fa = Running at free air · cs = Customer specs · cu = Customer unit  
Subject to alterations



## Technical features

Mass	4.6 kg
Size	310 mm
Surface of rotor	Coated in black
Material of electronics housing	Die-cast aluminium
Material of impeller	PP plastic
Number of blades	6
Direction of rotation	Clockwise, seen on rotor
Type of protection	IP 54
Insulation class	"B"
Humidity class	F3-1
Max. permissible ambient motor temp. (transp./ storage)	+80 °C
Min. permissible ambient motor temp. (transp./storage)	-40 °C
Mounting position	Any
Condensate discharge holes	None
Operation mode	S1
Motor bearing	Ball bearing
Technical features	<ul style="list-style-type: none"> <li>- Output 10 VDC, max. 10 mA</li> <li>- Alarm relay</li> <li>- Motor current limit</li> <li>- PFC, active</li> <li>- Soft start</li> <li>- Control input 0-10 VDC / PWM</li> <li>- Control interface with SELV potential safely disconnected from the mains</li> <li>- Over-temperature protected electronics / motor</li> <li>- Line undervoltage / phase failure detection</li> </ul>
EMC interference immunity	Acc. to EN 61000-6-2 (industrial environment)
EMC harmonics	Acc. to EN 61000-3-2/3
EMC interference emission	Acc. to EN 61000-6-4 (industrial environment)
Touch current acc. IEC 60990 (measuring network Fig. 4, TN system)	<= 3.5 mA
Motor protection	Thermal overload protector (TOP) wired internally
Cable exit	Variable
Protection class	I (if protective earth is connected by customer)
Product conforming to standard	EN 61800-5-1
Approval	CSA C22.2 Nr.77; EAC; UL 2111

Product drawing

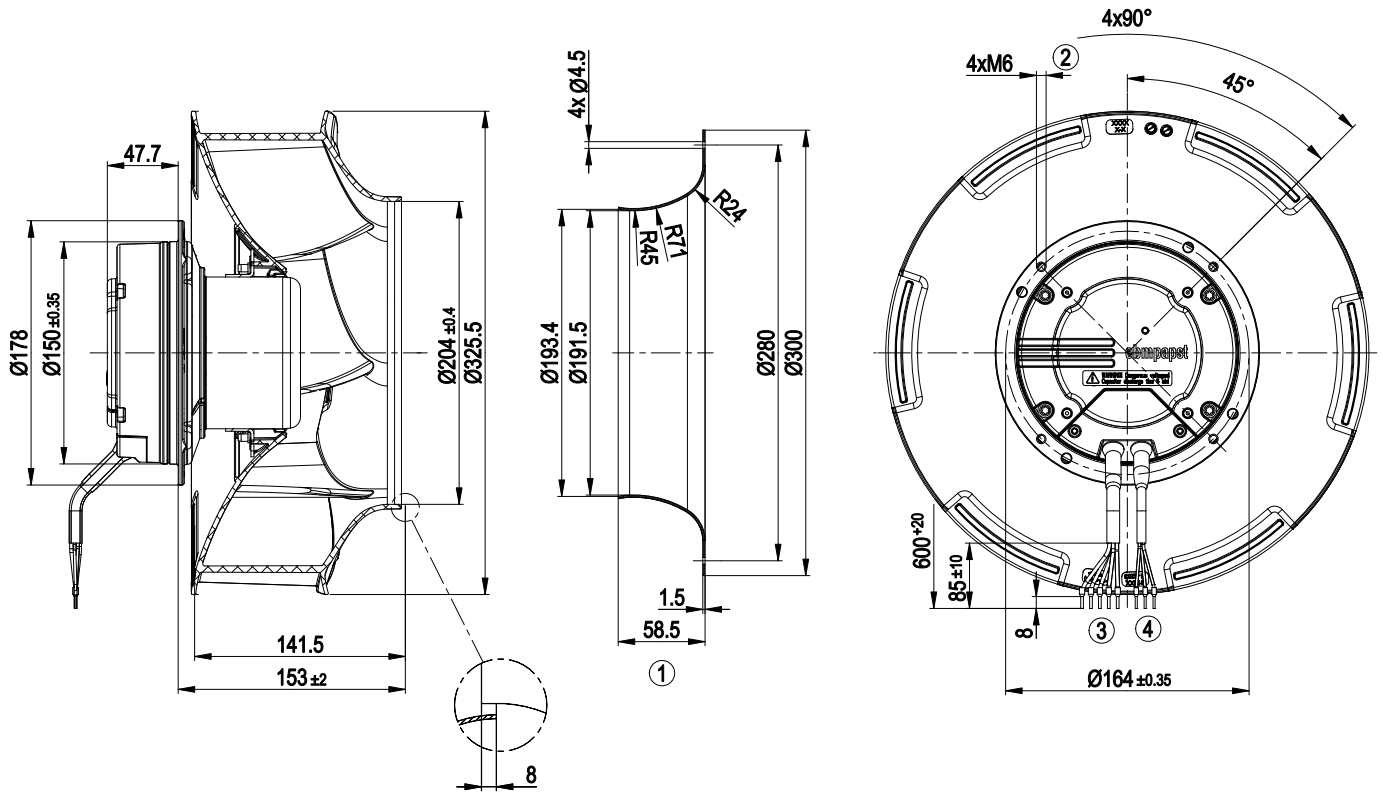

1	Accessory part: Inlet nozzle 31000-2-4013 not included in scope of delivery
2	Thread reach max. 10 mm
3	Connection line, PVC AWG18, 5x crimped core-end sleeves
4	Connection line, PVC AWG22, 3x crimped core-end sleeves

## Connection screen

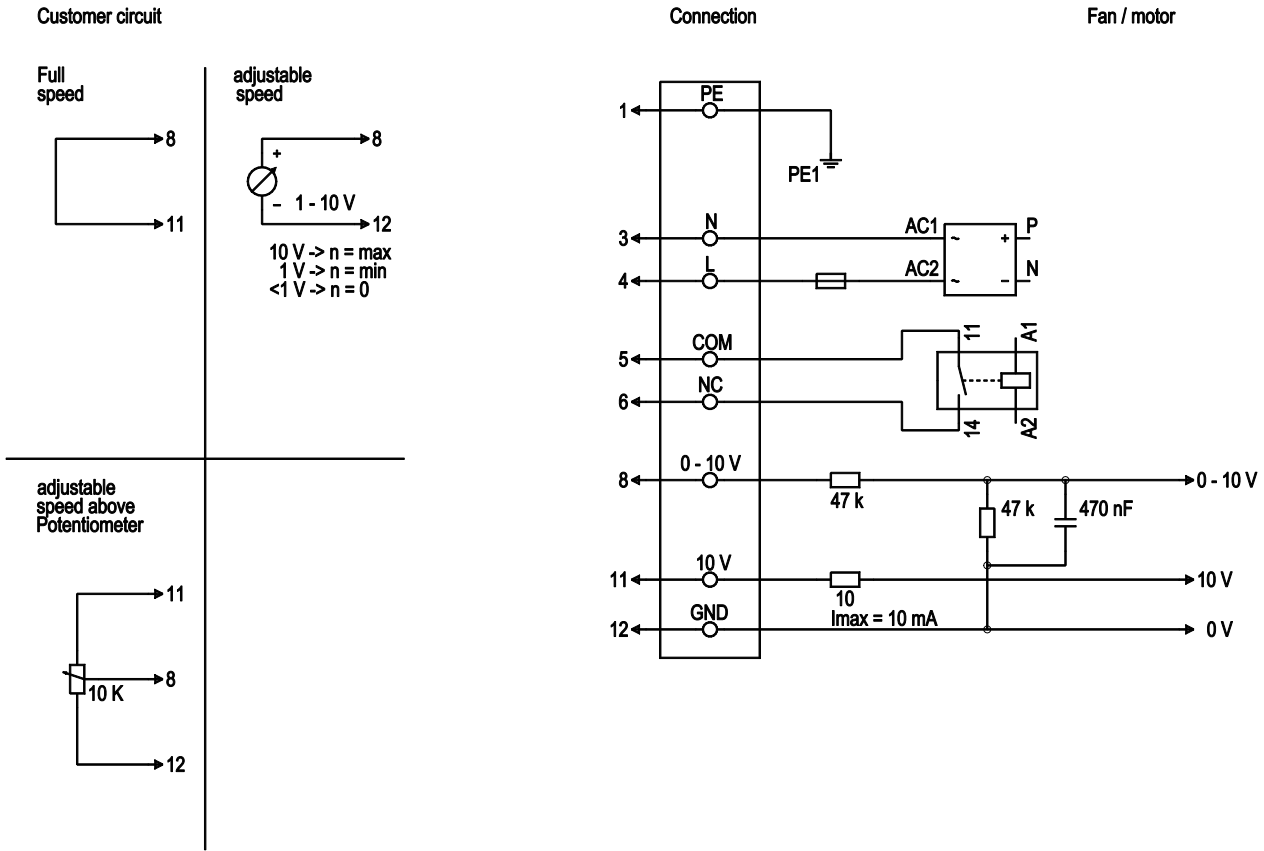

No.	Conn.	Designation	Colour	Function / assignment
1	1	PE	green/yellow	Protective earth
1	3	N	blue	Supply voltage, neutral conductor, 50/60 Hz
1	4	L	black	Supply voltage, phase, 50/60 Hz
1	5	COM	white 1	Floating status message contact, normally closed for error (2 A, max. 250 VAC, min. 10 mA)
1	6	NC	white 2	Floating status message contact, normally closed for error
2	8	0 - 10 V	yellow	Control input, set value 0 - 10 VDC, impedance 100 kΩ, SELV
2	11	10 VDC	red	Voltage output 10 VDC (+/-3%), max. 10 mA, supply voltage for external devices (e.g. potentiometer), SELV
2	12	GND	blue	Reference mass for control interface, SELV

## Charts: Air flow 50 Hz

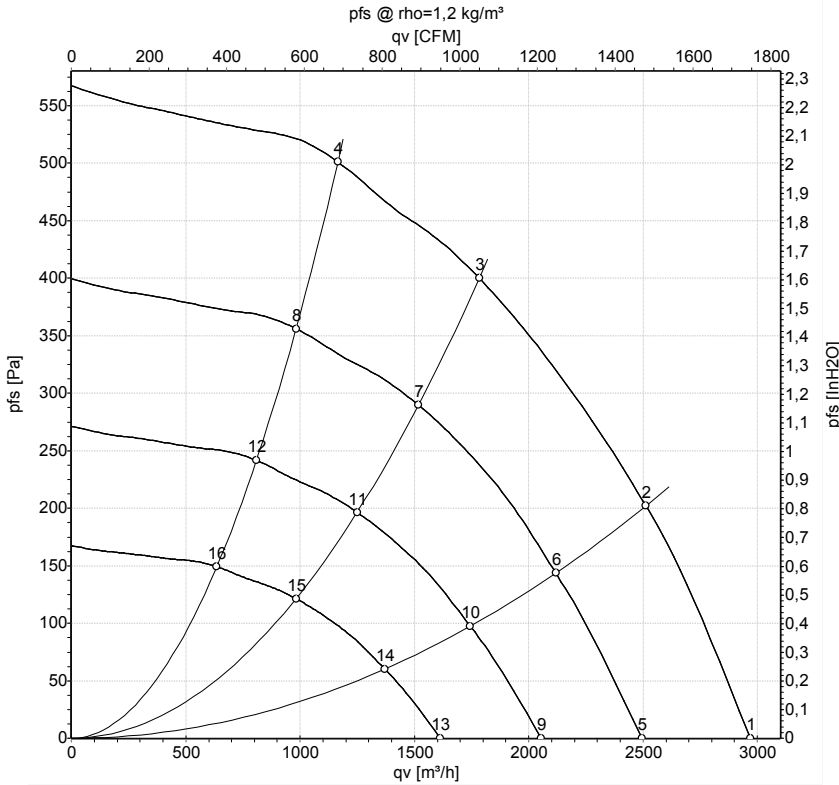

Measurement: LU-156646

Air performance measured as per ISO 5801 Installation category A. For detailed information on the measuring set-up, please contact ebm-papst. Suction-side noise levels: LwA measured as per ISO 13347 / LpA measured with 1m distance to fan axis. The values given are valid under the measuring conditions mentioned above and may vary according to the actual installation situation. With any deviation from the standard set-up, the specific values have to be checked and reviewed with the unit installed.

## Measured values

	U	f	n	P <sub>ed</sub>	I	LpA <sub>in</sub>	LwA <sub>in</sub>	qv	p <sub>fs</sub>
	V	Hz	min <sup>-1</sup>	W	A	dB(A)	dB(A)	m <sup>3</sup> /h	Pa
1	115	50	2010	253	2.20	68	76	2970	0
2	115	50	2010	320	2.79	65	72	2510	200
3	115	50	2010	345	3.00	64	70	1785	400
4	115	50	2010	319	2.78	64	71	1165	500
5	115	50	1700	150	1.31	64	71	2495	0
6	115	50	1700	192	1.67	61	68	2120	144
7	115	50	1700	213	1.85	60	66	1520	290
8	115	50	1700	191	1.67	60	67	985	356
9	115	50	1400	84	0.73	59	66	2055	0
10	115	50	1400	107	0.93	56	63	1745	97
11	115	50	1400	119	1.04	55	61	1250	197
12	115	50	1400	107	0.93	55	62	810	242
13	115	50	1100	41	0.35	53	60	1615	0
14	115	50	1100	52	0.45	50	57	1370	60
15	115	50	1100	58	0.50	49	55	980	121
16	115	50	1100	52	0.45	49	56	635	149

U = Supply voltage · f = Frequency · n = Speed · P<sub>ed</sub> = Power input · I = Current draw · LpA<sub>in</sub> = Sound pressure level inlet side · LwA<sub>in</sub> = Sound power level inlet side · qv = Air flow  
p<sub>fs</sub> = Pressure increase

