

R3G310-RB01-04 ebmpapst Datasheet

sales@fansco.com

www.fansco.com

Limited partnership · Headquarters Muldingen
County court Stuttgart · HRA 590344

General partner Elektrobau Muldingen GmbH · Headquarters Muldingen
County court Stuttgart · HRB 590142

Nominal data

Type	R3G310-RB01-04	
Motor	M3G074-CF	
Phase		1~
Nominal voltage	VAC	230
Nominal voltage range	VAC	200 .. 240
Frequency	Hz	50/60
Type of data definition		ml
Speed (rpm)	min ⁻¹	1525
Power input	W	150
Current draw	A	1.2
Min. ambient temperature	°C	-25
Max. ambient temperature	°C	60

ml = Max. load · me = Max. efficiency · fa = Running at free air · cs = Customer specs · cu = Customer unit
Subject to alterations

Data according to ErP directive

		Actual	Request 2015			
01 Overall efficiency η_{es}	%	65.9	42.5	09 Power input P_{ed}	kW	0.14
02 Measurement category		A		09 Air flow q_v	m ³ /h	1355
03 Efficiency category		Static		09 Pressure increase p_{fs}	Pa	229
04 Efficiency grade N		85.4	62	10 Speed (rpm) n	min ⁻¹	1520
05 Variable speed drive		Yes		11 Specific ratio [*]		1.00

Data definition with optimum efficiency.

The ErP data is determined using a motor-impeller combination in a standardised measurement configuration.

^{*} Specific ratio = $1 + p_{fs} / 100\,000\text{ Pa}$

LU-137969



Technical features

Mass	3.0 kg
Size	310 mm
Material of impeller	PP plastic
Number of blades	6
Direction of rotation	Clockwise, seen on rotor
Type of protection	IP 54
Insulation class	"B"
Humidity (F)/environmental protection class (H)	F3-1
Max. permissible ambient motor temp. (transp./ storage)	+ 80 °C
Min. permissible ambient motor temp. (transp./storage)	- 40 °C
Mounting position	Any
Cooling bore / aperture	Rotor-side
Operation mode	S1
Motor bearing	Ball bearing
Technical features	<ul style="list-style-type: none"> - Output 10 VDC, max. 10 mA - Tach output - Output limit - Motor current limit - Soft start - Control input 0-10 VDC / PWM - Control interface with SELV potential safely disconnected from the mains - Overvoltage detection - Over-temperature protected electronics / motor - Line undervoltage detection
Touch current acc. IEC 60990 (measuring network Fig. 4, TN system)	<= 3.5 mA
Motor protection	PTC resistor
Cable exit	Variable
Protection class	I (if protective earth is connected by customer)
Product conforming to standard	CE

Product drawing

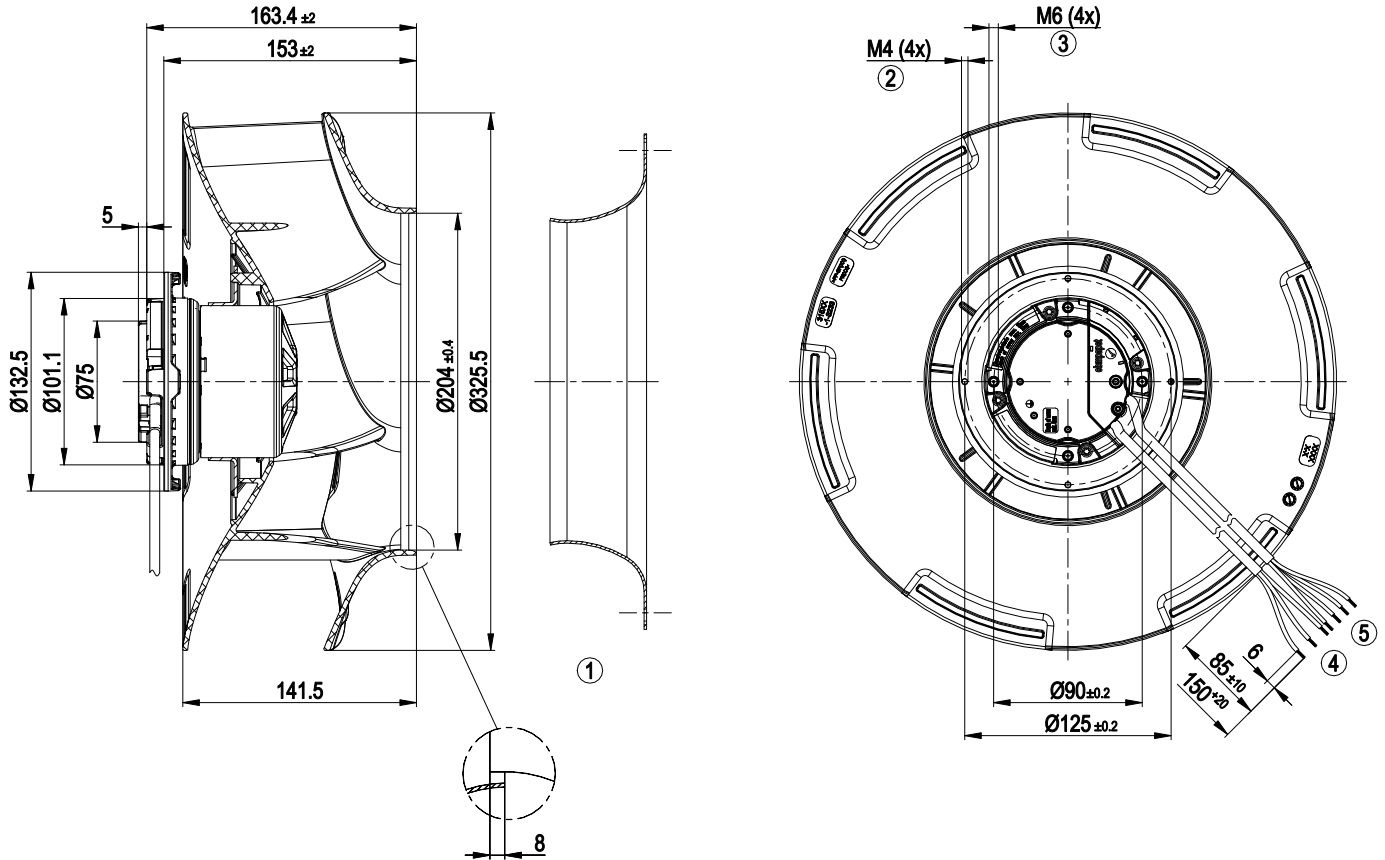

1	Accessory part: Inlet nozzle 31000-2-4013 not included in scope of delivery, other inlet nozzles on request
2	Thread reach max. 10 mm
3	Thread reach max. 10 mm
4	Connection line PVC AWG20, 3x lead tips crimped
5	Connection line PVC AWG22, 4x lead tips crimped



Accessory part

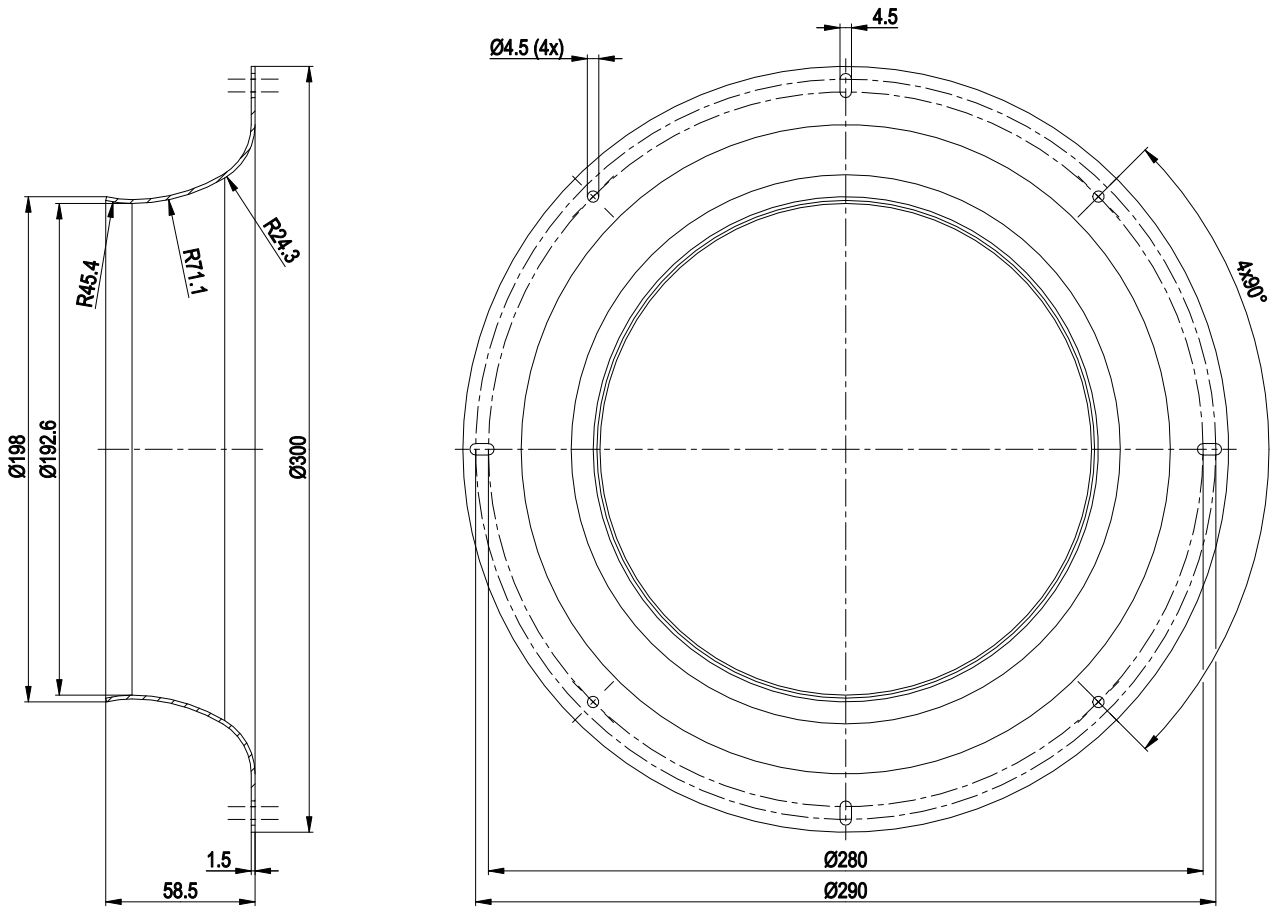

Accessory part: Inlet nozzle 31000-2-4013 not included in scope of delivery

Connection screen

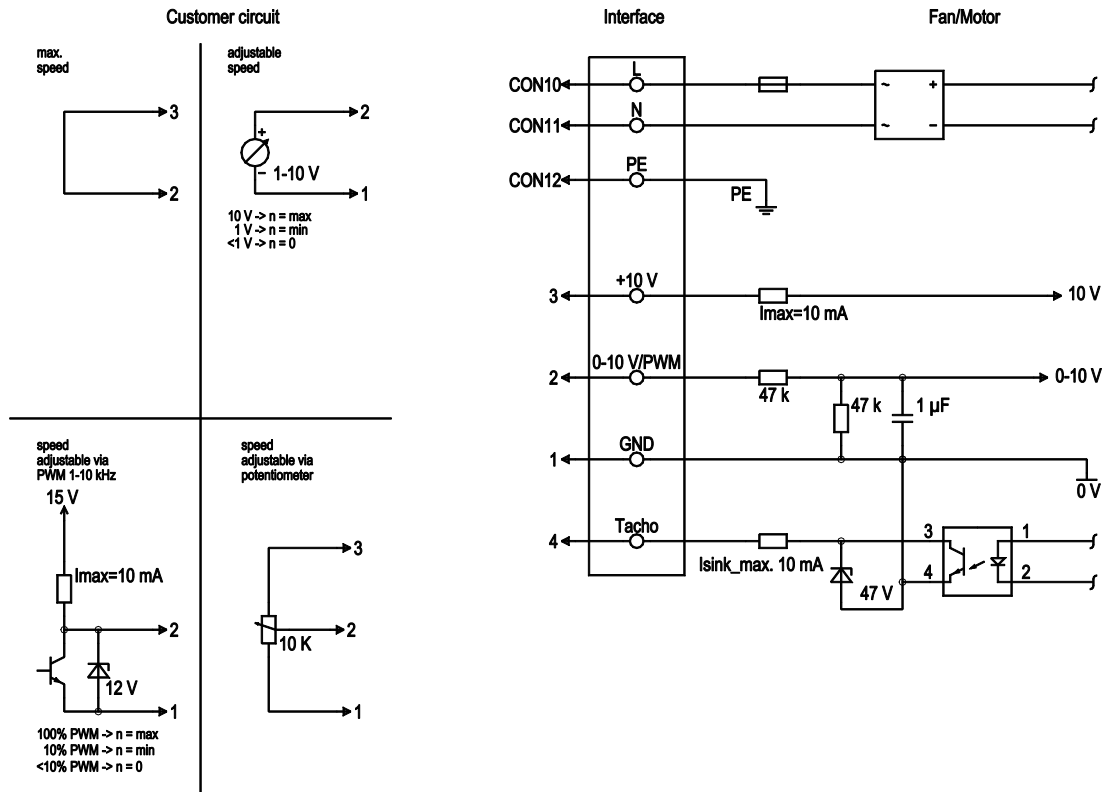

No.	Conn.	Designation	Colour	Function / assignment
	CON10	L	black	Mains connection, power supply, phase, see type plate for voltage range
	CON11	N	blue	Mains connection, power supply, neutral conductor, see type plate for voltage range
	CON12	PE	green/yellow	Earth connection
	2	0- 10V PWM	yellow	0-10 V/PWM control input, R _i =100 kΩ, SELV
	4	Tach	white	Speed monitoring output, open collector, 1 pulse per revolution, I _{sink max} = 10 mA, SELV
	3	+10 V	red	Fixed voltage output 10 VDC +/-3 %, I _{max} . 10 mA, short-circuit-proof, power supply for ext. devices (e.g. potentiometer), SELV
	1	GND	blue	Signal ground for control interface, SELV

Charts: Air flow 50 Hz

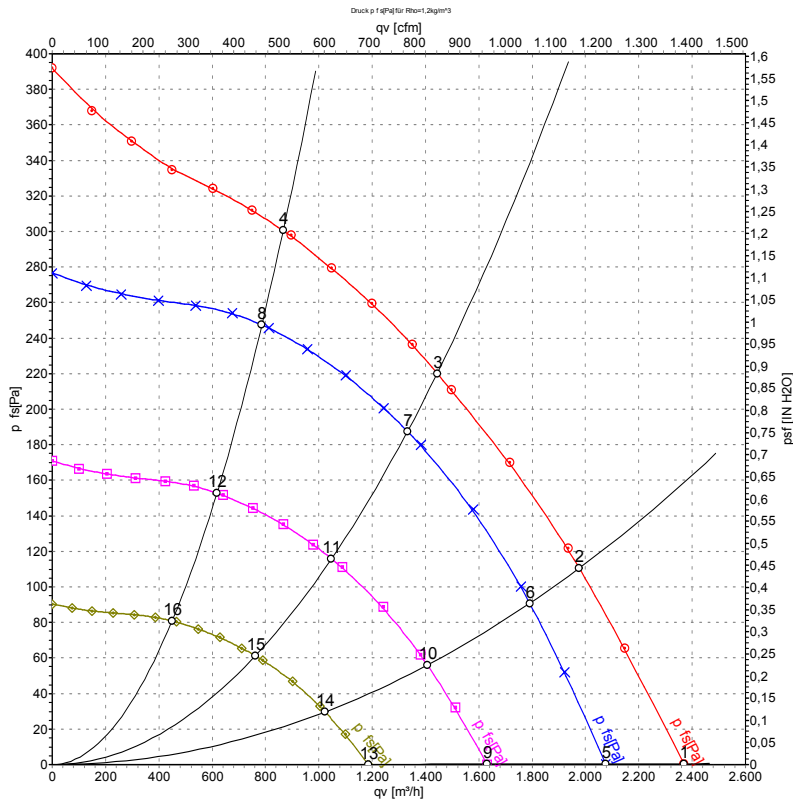

Measurement: LU-137969-1

Air performance measured as per ISO 5801 Installation category A. For detailed information on the measuring set-up, please contact ebmpapst. Suction-side noise levels: LwA measured as per ISO 13347 / LpA measured with 1m distance to fan axis. The values given are valid under the measuring conditions mentioned above and may vary according to the actual installation situation. With any deviation from the standard set-up, the specific values have to be checked and reviewed with the unit installed.

Measured values

	U	f	n	P _{ed}	I	LpA _{in}	LwA _{in}	q _v	P _{fs}	q _v	P _{fs}
	V	Hz	min ⁻¹	W	A	dB(A)	dB(A)	m ³ /h	Pa	cfm	inH2O
1	230	50	1600	115	0.95	62	69	2370	0	1395	0.00
2	230	50	1545	137	1.12	57	65	1975	110	1165	0.44
3	230	50	1525	150	1.20	52	59	1445	220	850	0.88
4	230	50	1545	137	1.13	55	62	865	300	510	1.20
5	230	50	1400	77	0.64	59	66	2075	0	1220	0.00
6	230	50	1400	102	0.84	55	63	1790	91	1055	0.37
7	230	50	1400	118	0.97	50	57	1335	188	785	0.75
8	230	50	1400	102	0.84	53	60	785	248	465	1.00
9	230	50	1100	37	0.31	54	61	1630	0	960	0.00
10	230	50	1100	50	0.41	50	57	1405	56	830	0.22
11	230	50	1100	57	0.47	45	52	1045	116	615	0.47
12	230	50	1100	50	0.41	47	55	620	153	365	0.61
13	230	50	800	14	0.12	47	54	1185	0	700	0.00
14	230	50	800	19	0.16	43	50	1025	30	600	0.12
15	230	50	800	22	0.18	38	45	760	61	450	0.24
16	230	50	800	19	0.16	40	48	450	81	265	0.33

U = Supply voltage · f = Frequency · n = Speed (rpm) · P_{ed} = Power input · I = Current draw · LpA_{in} = Sound pressure level inlet side · LwA_{in} = Sound power level inlet side · q_v = Air flow
 P_{fs} = Pressure increase

