

R3G310-FS10-J1 ebmpapst Datasheet

sales@fansco.com

www.fansco.com

## Nominal data

Type	R3G310-FS10-J1	
Motor	M3G084-FA	
Phase		3~
Nominal voltage	VAC	400
Nominal voltage range	VAC	380 .. 480
Frequency	Hz	50/60
Method of obtaining data		ml
Speed (rpm)	min <sup>-1</sup>	3100
Power consumption	W	1100
Current draw	A	1.7
Min. ambient temperature	°C	-40
Max. ambient temperature	°C	40

ml = Max. load · me = Max. efficiency · fa = Free air · cs = Customer specification · ce = Customer equipment  
Subject to change

## Data according to Commission Regulation (EU) 327/2011 (EN 17166)

		Actual	Req. 2015			
01 Overall efficiency $\eta_{es}$	%	69.5	51.8	09 Power consumption $P_{ed}$	kW	1.06
02 Measurement category		A		09 Air flow $q_v$	m <sup>3</sup> /h	3205
03 Efficiency category		Static		09 Pressure increase $p_{fs}$	Pa	770
04 Efficiency grade N		79.7	62	10 Speed (rpm) n	min <sup>-1</sup>	3105
05 Variable speed drive		Yes		11 Specific ratio*		1.01

Data obtained at optimum efficiency level.

The ErP data is determined using a motor-impeller combination in a standardized measurement setup.

\* Specific ratio =  $1 + p_{fs} / 100\,000\text{ Pa}$

LU-208726



## Technical description

<b>Weight</b>	5.54 kg
<b>Size</b>	310 mm
<b>Motor size</b>	84
<b>Rotor surface</b>	Painted black
<b>Electronics housing material</b>	Die-cast aluminum
<b>Impeller material</b>	PP plastic
<b>Number of blades</b>	6
<b>Direction of rotation</b>	Clockwise, viewed toward rotor
<b>Degree of protection</b>	IP55
<b>Insulation class</b>	"F"
<b>Moisture (F) / Environmental (H) protection class</b>	H1
<b>Ambient temperature note</b>	Occasional start-up at temperatures between -40°C and -25°C is permitted. For continuous operation at ambient temperatures below -25°C (such as refrigeration applications), use must be made of a fan design with special low-temperature bearings.
<b>Max. permitted ambient temp. for motor (transport/storage)</b>	+80 °C
<b>Min. permitted ambient temp. for motor (transport/storage)</b>	-40 °C
<b>Installation position</b>	Shaft horizontal or rotor on bottom; rotor on top on request
<b>Condensation drainage holes</b>	On rotor side
<b>Mode</b>	S1
<b>Motor bearing</b>	Ball bearing
<b>Technical features</b>	<ul style="list-style-type: none"> <li>- Output 10 VDC, max. 10 mA</li> <li>- Operation and alarm display</li> <li>- External 24 V input (parameter setting)</li> <li>- Alarm relay</li> <li>- Integrated PID controller</li> <li>- Motor current limitation</li> <li>- PFC, passive</li> <li>- RS-485 MODBUS-RTU</li> <li>- Soft start</li> <li>- EEPROM write cycles: 100,000 maximum</li> <li>- Control input 0-10 VDC / PWM</li> <li>- Control interface with SELV potential safely disconnected from the mains</li> <li>- Thermal overload protection for electronics/motor</li> <li>- Line undervoltage / phase failure detection</li> </ul>
<b>EMC immunity to interference</b>	According to EN 61000-6-2 (industrial environment)
<b>EMC interference emission</b>	According to EN 61000-6-3 (household environment), except EN 61000-3-2 for professionally used equipment with a total rated power greater than 1 kW
<b>Touch current according to IEC 60990 (measuring circuit Fig. 4, TN system)</b>	<= 3.5 mA
<b>Motor protection</b>	Thermal overload protector (TOP) internally connected
<b>With cable</b>	Variable
<b>Protection class</b>	I (with customer connection of protective earth)
<b>Conformity with standards</b>	EN 61800-5-1; CE
<b>Approval</b>	CSA C22.2 No. 77 + CAN/CSA-E60730-1; EAC; UL 1004-7 + 60730-1

Product drawing

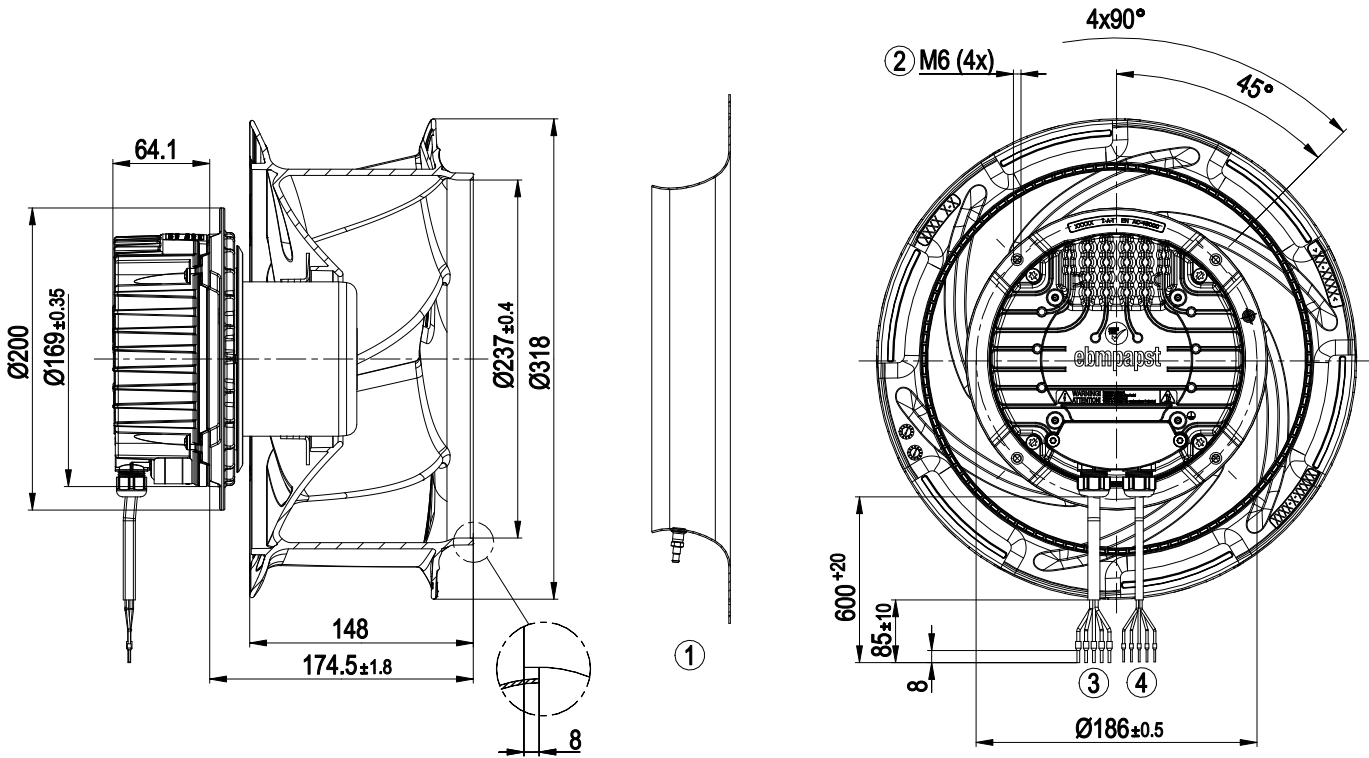

1	Accessory part: Inlet ring 31555-2-4013 with pressure tap (k-factor: 128) not included in scope of delivery
2	Max. clearance for screw 10 mm
3	Cable PVC AWG18 6x wire-end ferrule
4	Cable PVC AWG22 5x wire-end ferrule



## Accessory part

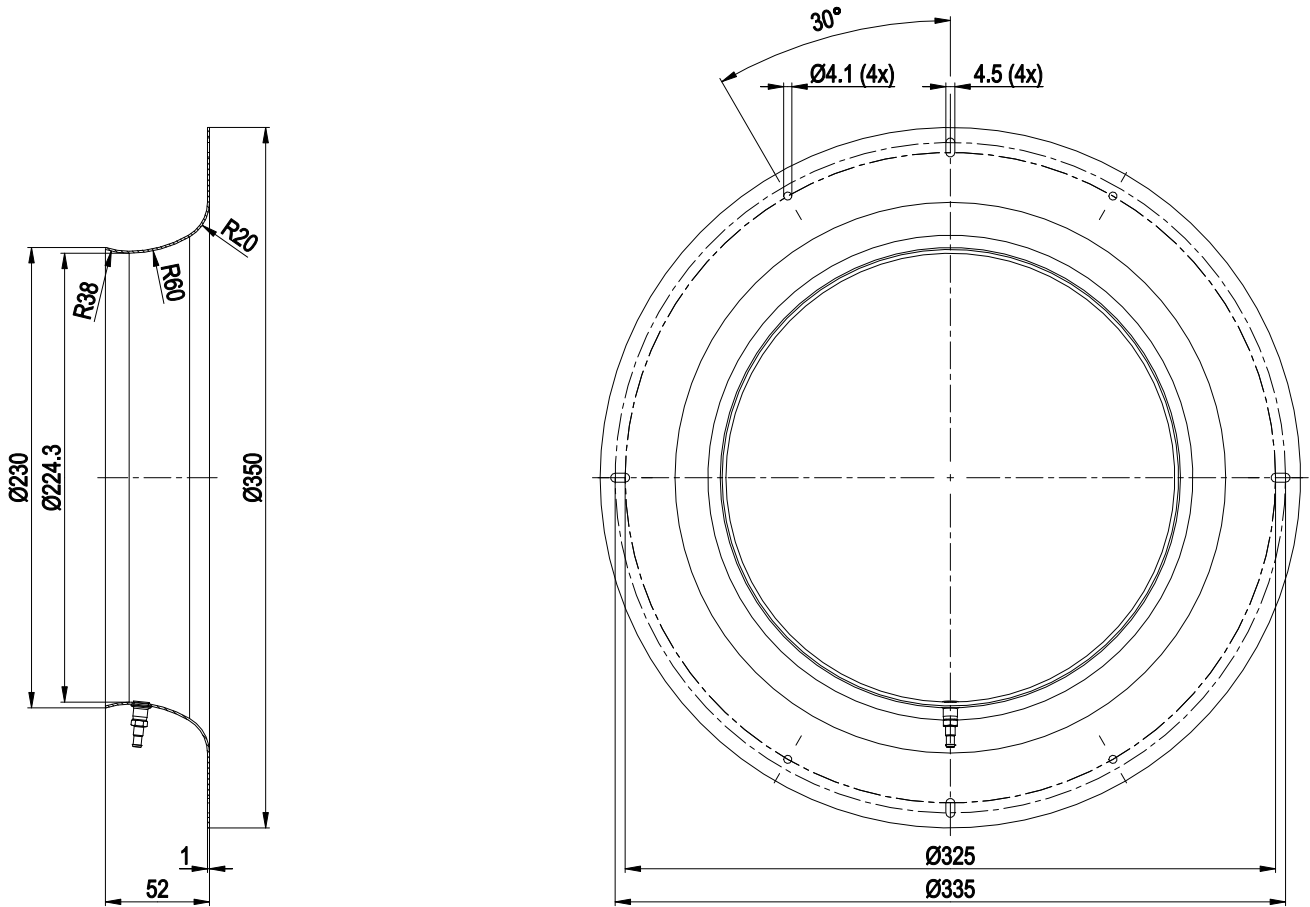

Inlet ring 31555-2-4013 with pressure tap (k-factor: 128)

## Connection diagram

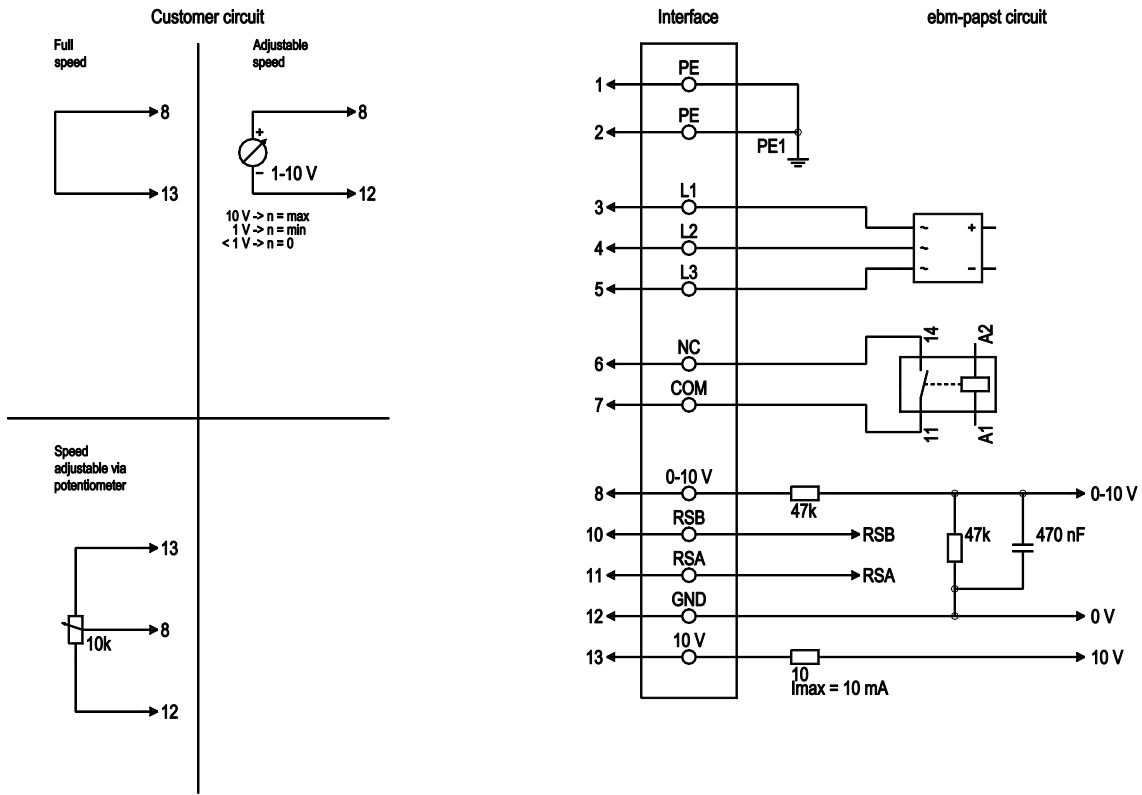

No.	Conn.	Designation	Color	Function/assignment
1	1, 2	PE	green/yellow	Protective earth
1	3	L1	black	Power supply
1	4	L2	black	Power supply
1	5	L3	black	Power supply
1	6	NC	white 1	Status relay, floating status contact, break for failure, contact rating 250 VAC / 2 A (AC1) / min. 10 mA; reinforced insulation on supply side and basic insulation on control interface side
1	7	COM	white 2	Status relay, floating status contact, break for failure, contact rating 250 VAC / 2 A (AC1) / min. 10 mA; reinforced insulation on supply side and basic insulation on control interface side
2	8	0-10V	yellow	Analog input (set value), 0-10 V, $R_i = 100\text{ k}\Omega$ , adjustable curve, SELV
2	10	RSB	brown	RS485 interface for MODBUS, RSB; SELV
2	11	RSA	white	RS485 interface for MODBUS, RSA; SELV
2	12	GND	blue	Reference ground for control interface, SELV
2	13	+10V	red	Fixed voltage output 10 VDC, $+10\text{ V} \pm 3\%$ , max. 10 mA, short-circuit-proof power supply for external devices (e.g. pot), SELV fixed voltage input 24 VDC for setting parameters via MODBUS without line voltage supply



## Curves: Air performance 50 Hz

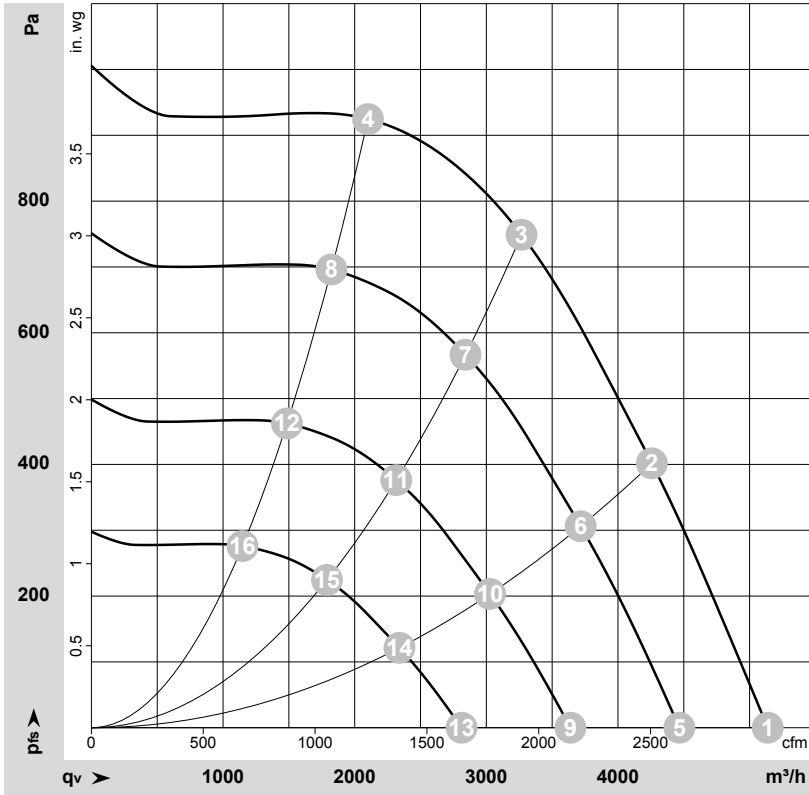

$\rho = 1.15 \text{ kg/m}^3 \pm 2 \%$

Measurement: LU-208726-1

Air performance measured according to ISO 5801 installation category A. For detailed information on the measurement setup, contact ebmpapst. Intake sound level: Sound power level according to ISO 13347 / sound pressure level measured at 1 m distance from fan axis. The values given are valid under the specified measuring conditions and may vary due to conditions of installation. For deviations from the standard configuration, the parameters have to be checked on the installed unit.

## Measured values

	Wired	U	f	n	P <sub>ed</sub>	I	LpA <sub>in</sub>	LwA <sub>in</sub>	q <sub>v</sub>	P <sub>fs</sub>	q <sub>v</sub>	P <sub>fs</sub>
		V	Hz	min <sup>-1</sup>	W	A	dB(A)	dB(A)	m <sup>3</sup> /h	Pa	cfm	in. wg
1	3~	400	50	3100	718	1.13	80	86	5140	0	3025	0.00
2	3~	400	50	3100	974	1.51	76	82	4260	400	2505	1.61
3	3~	400	50	3100	1100	1.70	72	78	3265	750	1925	3.01
4	3~	400	50	3100	995	1.54	75	82	2100	925	1235	3.71
5	3~	400	50	2700	472	0.74	76	83	4465	0	2630	0.00
6	3~	400	50	2700	648	1.00	72	78	3715	306	2190	1.23
7	3~	400	50	2700	702	1.08	68	75	2840	568	1675	2.28
8	3~	400	50	2700	650	1.01	71	78	1825	697	1075	2.80
9	3~	400	50	2200	255	0.40	71	78	3640	0	2140	0.00
10	3~	400	50	2200	350	0.54	67	73	3030	203	1780	0.81
11	3~	400	50	2200	380	0.59	63	70	2315	377	1365	1.51
12	3~	400	50	2200	352	0.54	66	73	1485	463	875	1.86
13	3~	400	50	1700	118	0.19	64	71	2810	0	1655	0.00
14	3~	400	50	1700	162	0.25	61	67	2340	121	1375	0.49
15	3~	400	50	1700	175	0.27	57	63	1790	225	1055	0.90
16	3~	400	50	1700	162	0.25	60	67	1150	276	675	1.11

Wired = Wiring · U = Voltage · f = Frequency · n = Speed (rpm) · P<sub>ed</sub> = Power consumption · I = Current draw · LpA<sub>in</sub> = Sound pressure level intake side · LwA<sub>in</sub> = Sound power level intake side  
 q<sub>v</sub> = Air flow · P<sub>fs</sub> = Pressure increase

