

EC centrifugal fan

backward-curved, single-intake

for rail applications

R3G310-BE90-N6 ebmpapst Datasheet

sales@fansco.com

www.fansco.com

Limited partnership · Headquarters Muldingen

Amtsgericht (court of registration) Stuttgart · HRA 590344

General partner Elektrobau Muldingen GmbH · Headquarters Muldingen

Amtsgericht (court of registration) Stuttgart · HRB 590142

Nominal data

Type	R3G310-BE90-N6	
Motor	M3G112-EA	
Phase		3~
Nominal voltage	VAC	400
Nominal voltage range	VAC	380 .. 480
Frequency	Hz	50/60
Method of obtaining data		ml
Status		prelim.
Speed (rpm)	min ⁻¹	2900
Power consumption	W	1300
Current draw	A	2.0
Min. ambient temperature	°C	-40
Max. ambient temperature	°C	60

ml = Max. load · me = Max. efficiency · fa = Free air · cs = Customer specification · ce = Customer equipment
Subject to change



EC centrifugal fan

backward-curved, single-intake

for rail applications

Technical description

Weight	8.5 kg
Size	310 mm
Motor size	112
Rotor surface	Painted black
Electronics housing material	Die-cast aluminum
Impeller material	Sheet aluminum
Number of blades	7
Direction of rotation	Counterclockwise, viewed toward rotor
Degree of protection	IP55
Insulation class	"F"
Moisture (F) / Environmental (H) protection class	H3
Ambient temperature note	Occasional start-up at temperatures between -40°C and -25°C is permitted. For continuous operation at ambient temperatures below -25°C (such as refrigeration applications), use must be made of a fan design with special low-temperature bearings.
Max. permitted ambient temp. for motor (transport/storage)	+80 °C
Min. permitted ambient temp. for motor (transport/storage)	-40 °C
Installation position	Shaft horizontal or rotor on bottom; rotor on top on request
Condensation drainage holes	On rotor side
Mode	S1
Motor bearing	Ball bearing; (sealed)
Technical features	<ul style="list-style-type: none"> - Output 10 VDC, max. 10 mA - Alarm relay - Integrated PID controller - Run monitoring - Power limiter - Motor current limitation - Emergency operation - PFC, passive - RS-485 MODBUS-RTU - Soft start - EEPROM write cycles: 100,000 maximum - Control input 0-10 VDC / PWM - Control interface with SELV potential safely disconnected from the mains - Overvoltage detection - Thermal overload protection for electronics/motor - Line undervoltage / phase failure detection
EMC regulations	According to EN 50121-3-2
Touch current according to IEC 60990 (measuring circuit Fig. 4, TN system)	<= 3.5 mA
Motor protection	Thermal overload protector (TOP) internally connected
With cable	Lateral
Protection class	I (if protective earth is connected by customer to the housing's connection point)
Conformity with standards	EN 15085-1, CPC3: 2013; EN 45545-2, HL3: 2013; EN 50155: 2008; EN 61373, Cat. 1B: 2010
Approval	EAC



EC centrifugal fan

backward-curved, single-intake

for rail applications

Comment

A prerequisite for operation is a Class 1 vehicle electrical system architecture according to EN 50533; if supply potential (e.g. 230 VAC) is passed through the alarm relay, the SELV signal wires lose their property of reinforced insulation and they then have only basic insulation

The SELV property (reinforced insulation) is not lost when voltages of up to 110 VDC are passed through the alarm relay.



EC centrifugal fan

backward-curved, single-intake
for rail applications

Product drawing

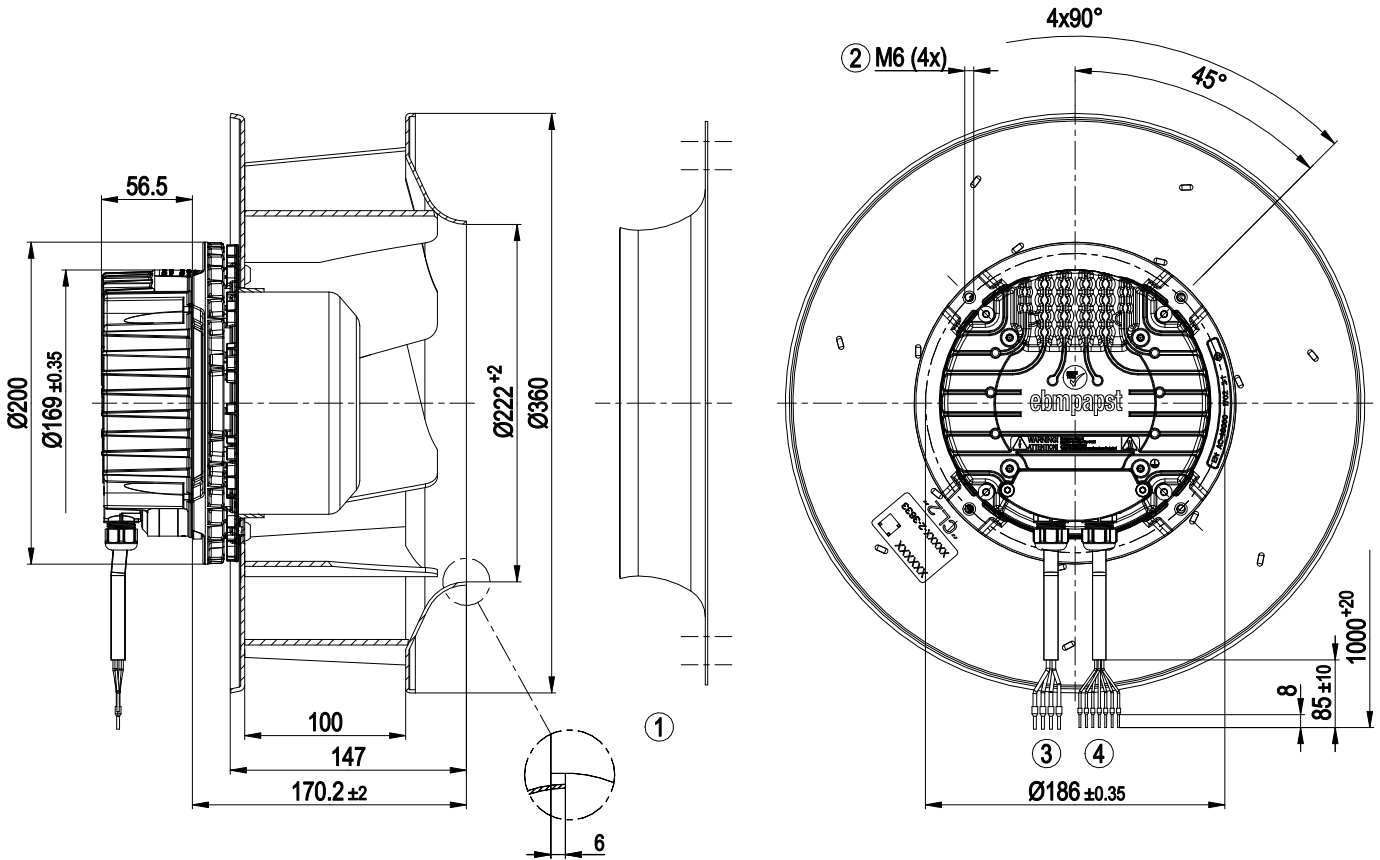

1	Accessory part: inlet ring 31570-2-4013 not included in scope of delivery
2	Max. clearance for screw 16 mm
3	Cable halogen-free, BETAtans® 3 GKW flex, 4G 1.5 mm ² 4x wire-end ferrule
4	Cable halogen-free, BETAtans® 3 GKW flex, 7x 0.5 mm ² 7x wire-end ferrule



EC centrifugal fan

backward-curved, single-intake
for rail applications

Connection diagram

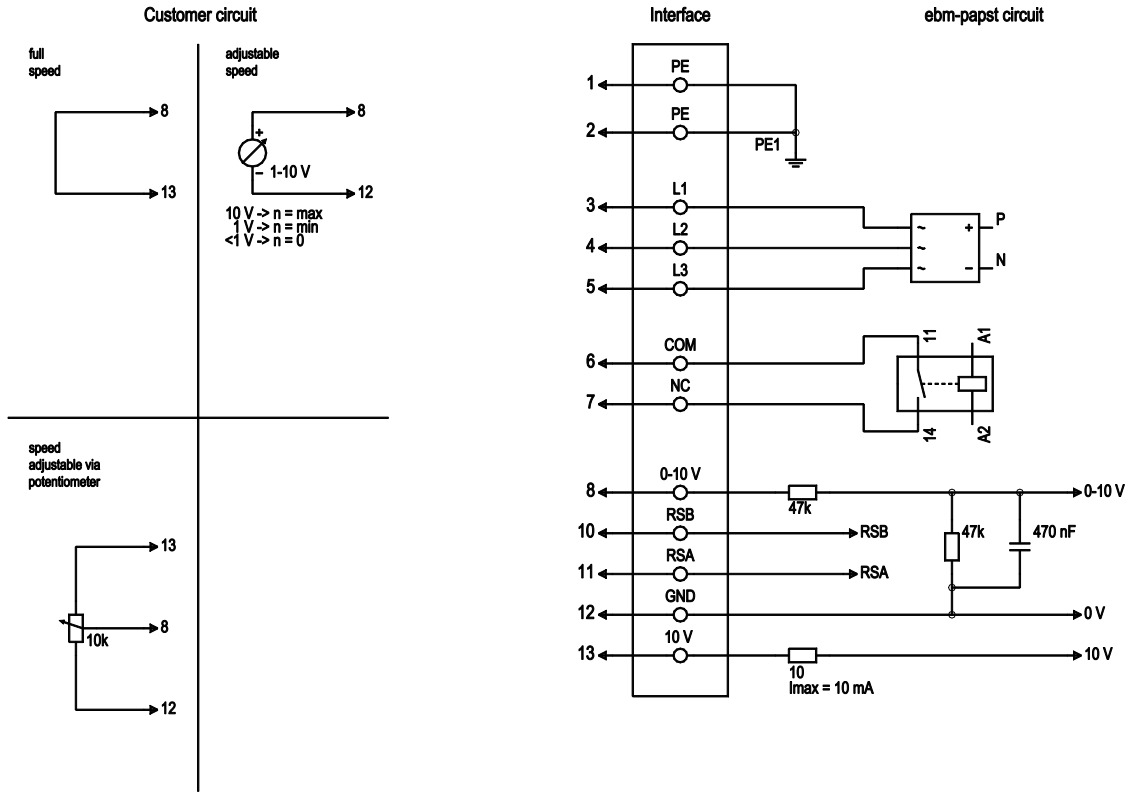

No.	Conn.	Designation	Function/assignment
1	1, 2	PE	Protective earth
1	3	L1	Power supply, phase
1	4	L2	Power supply, phase
1	5	L3	Power supply, phase
2	6	COM	Status relay, floating status contact, common connection, contact rating 250 VAC / 30 VDC 5 A minimum contact separation 1 mA / 5 VDC, reinforced insulation on supply side, basic insulation on control interface side
2	7	NC	Status relay, floating status contact, break for failure, contact rating 250 VAC / 30 VDC 5 A minimum contact separation 1 mA / 5 VDC, reinforced insulation on supply side, basic insulation on control interface side
2	8	0-10 V	Analog input (set value) SELV, 0-10 V, $R_i = 100\text{ k}\Omega$, adjustable curve
2	10	RSB	RS485 interface for MODBUS, RSB; SELV
2	11	RSA	RS485 interface for MODBUS, RSA; SELV
2	12	GND	Reference ground for interface, SELV
2	13	+10 V	Fixed voltage output 10 VDC, SELV, +10 V $\pm 3\%$, max. 10 mA, short-circuit-proof, power supply for external devices (e.g. potentiometers)



Curves: Air performance 50 Hz

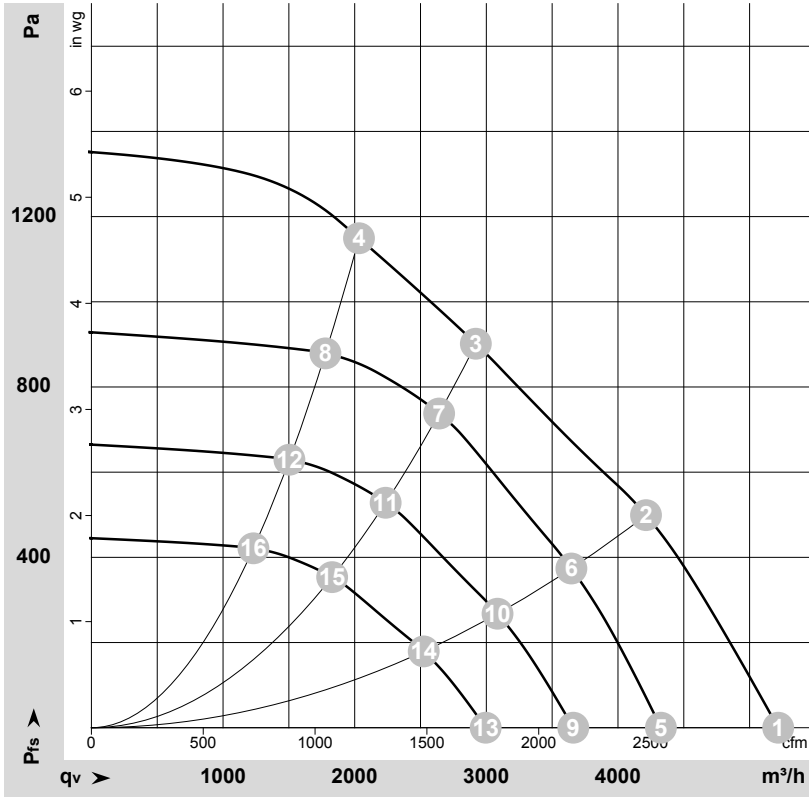

$\rho = 1.15 \text{ kg/m}^3 \pm 2 \%$

Measurement: LU-179252-1

Air performance measured according to ISO 5801 installation category A. For detailed information on the measurement setup, contact ebmpapst. Intake sound level: Sound power level according to ISO 13347 / sound pressure level measured at 1 m distance from fan axis. The values given are valid under the specified measuring conditions and may vary due to conditions of installation. For deviations from the standard configuration, the parameters have to be checked on the installed unit.

Measured values

	U	f	n	P _{ed}	I	LpA _{in}	LwA _{in}	LwA _{out}	q _v	P _{fs}	q _v	P _{fs}
	V	Hz	min ⁻¹	W	A	dB(A)	dB(A)	dB(A)	m ³ /h	Pa	cfm	in. wg
1	400	50	3135	1229	1.89	82	90	96	5215	0	3070	0.00
2	400	50	3005	1300	2.00	76	85	91	4215	500	2480	2.01
3	400	50	2900	1300	2.00	72	80	86	2920	900	1720	3.61
4	400	50	2970	1300	2.00	76	85	90	2035	1150	1195	4.62
5	400	50	2600	701	1.08	77	85	91	4325	0	2545	0.00
6	400	50	2600	842	1.29	73	81	88	3645	379	2145	1.52
7	400	50	2600	940	1.44	69	77	84	2640	738	1555	2.96
8	400	50	2600	866	1.33	72	82	86	1780	881	1045	3.54
9	400	50	2200	425	0.65	73	81	87	3660	0	2155	0.00
10	400	50	2200	510	0.78	68	77	83	3085	271	1815	1.09
11	400	50	2200	569	0.87	65	73	79	2235	529	1315	2.12
12	400	50	2200	524	0.81	68	77	82	1505	631	885	2.53
13	400	50	1800	233	0.36	68	76	82	2995	0	1765	0.00
14	400	50	1800	279	0.43	63	72	78	2525	181	1485	0.73
15	400	50	1800	312	0.48	60	68	74	1830	354	1075	1.42
16	400	50	1800	287	0.44	63	72	77	1230	422	725	1.69

U = Voltage · f = Frequency · n = Speed (rpm) · P_{ed} = Power consumption · I = Current draw · LpA_{in} = Sound pressure level intake side · LwA_{in} = Sound power level intake side
LwA_{out} = Sound power level outlet side · q_v = Air flow · P_{fs} = Pressure increase

