

R3G310-BE84-S1

# EC centrifugal fan - RadiPac

backward curved, single inlet

for railway applications



R3G310-BE84-S1 ebmpapst Datasheet

sales@fansco.com

www.fansco.com

Limited partnership · Headquarters Mulfingen  
County court Stuttgart · HRA 590344

General partner Elektrobau Mulfingen GmbH · Headquarters Mulfingen  
County court Stuttgart · HRB 590142

## Nominal data

Type	R3G310-BE84-S1	
Motor	M3G112-EA	
Nominal voltage	VDC	110
Nominal voltage range	VDC	77 .. 138
Type of data definition		ml
Speed (rpm)	min <sup>-1</sup>	2650
Power input	W	995
Current draw	A	9.0
Min. ambient temperature	°C	-40
Max. ambient temperature	°C	60

ml = Max. load · me = Max. efficiency · fa = Running at free air · cs = Customer specs · cu = Customer unit  
Subject to alterations

## Data in accordance with ecodesign regulation EU 327/2011 (EN 17166)

		Actual	Request 2015			
01 Overall efficiency $\eta_{es}$	%	60.1	51.5	09 Power input $P_e$	kW	1
02 Measurement category		A		09 Air flow $q_v$	m <sup>3</sup> /h	2515
03 Efficiency category		Static		09 Pressure increase $p_{fs}$	Pa	796
04 Efficiency grade N		70.6	62	10 Speed (rpm) n	min <sup>-1</sup>	2635
05 Variable speed drive		Yes		11 Specific ratio*		1.01

Data definition with optimum efficiency.

\* Specific ratio =  $1 + p_{fs} / 100\,000\text{ Pa}$

LU-181121

The indicated efficiency values for obtaining conformity with the Ecodesign Directive EU 327/2011 were achieved with defined air conduction components (e.g. inlet nozzles). The dimensions are to be requested from ebm-papst. If other air guide geometries are used on the installation side, the ebm-papst evaluation loses its validity/conformity must be confirmed again. The product does not fall within the scope of Regulation (EU) 2019/1781 due to the exception specified in Article 2(2a) (motors completely integrated into a product).



### Technical features

Mass	8.78 kg
Size	310 mm
Motor size	112
Surface of rotor	Coated in black
Material of impeller	Aluminium sheet
Housing material	Die-cast aluminium
Number of blades	7
Direction of rotation	Clockwise, seen on rotor
Type of protection	IP55
Insulation class	"F"
Humidity (F) / environmental protection class (H)	H3
Max. permissible ambient motor temp. (transp./ storage)	+80 °C
Min. permissible ambient motor temp. (transp./storage)	-40 °C
Mounting position	Rotor on top
Condensation drainage holes	Rotor-side
Operation mode	S1
Motor bearing	Ball bearing; (sealed)
Technical features	<ul style="list-style-type: none"> <li>- Output 10 VDC, max. 10 mA</li> <li>- Operation and alarm display</li> <li>- Alarm relay</li> <li>- Motor current limit</li> <li>- RS485 MODBUS RTU</li> <li>- Soft start</li> <li>-Maximum EEPROM write cycles 100,000</li> <li>- Control input 0-10 VDC / PWM</li> <li>- Control interface with SELV potential safely disconnected from the mains</li> <li>- Overvoltage detection</li> <li>- Over-temperature protected electronics / motor</li> <li>- Line undervoltage detection</li> </ul>
EMC directives	According to EN 50121-3-2
Motor protection	Thermal overload protector (TOP) wired internally
Cable exit	Lateral
Safety classification	<p>I; If a protective earth is connected by the customer.</p> <p>This component to be built-in can have several local safety classifications.</p> <p>This specification relates to the basic design of this component.</p> <p>The final protection class is based on the intended installation and connection of the components.</p>
Product conforming to standard	EN 15085-1, CPC3; EN 45545-2, HL3; EN 50155; EN 61373, Cat. 1B; CE
Approval	EAC
Remark	<p>If voltage (e.g. 230 VAC) is passed through the alarm relay, the SELV signal wires lose their increased insulation, meaning they only have basic insulation</p> <p>The SELV property (increased insulation) is not lost when voltages of up to 110 VDC are passed through the alarm relay.</p>

# EC centrifugal fan - RadiPac

backward curved, single inlet  
for railway applications

## Product drawing

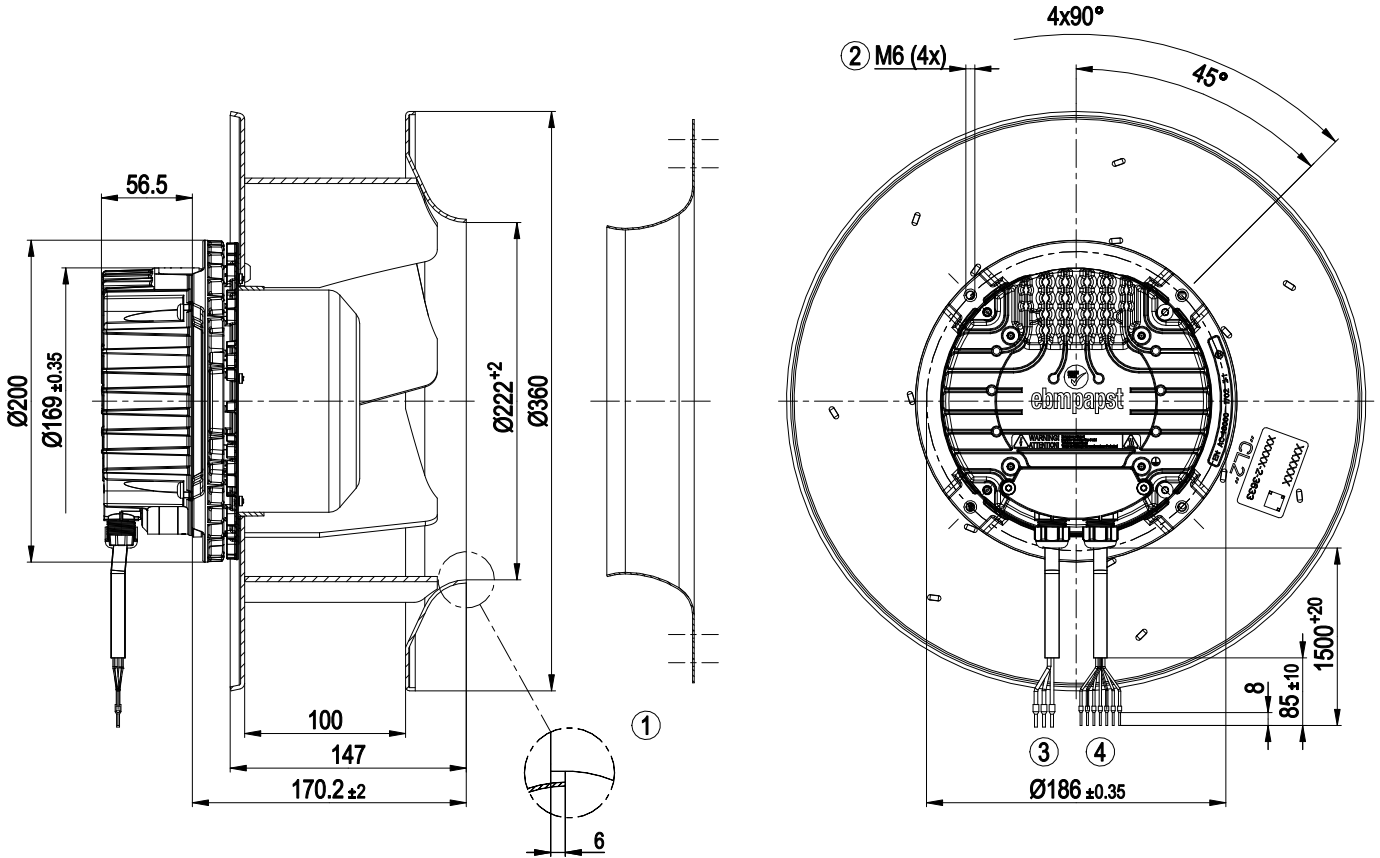

1	Accessory part: Inlet nozzle 31570-2-4013 not included in scope of delivery
2	Thread reach max. 16 mm
3	Connection line, halogen-free, railway application EN 45545, 4G 1.5 mm <sup>2</sup> 3x core-end sleeve, 1x lead not brought out
4	Connection line, halogen-free, railway application EN 45545, 7x 0.5 mm <sup>2</sup> 7x core-end sleeve



# EC centrifugal fan - RadiPac

backward curved, single inlet

for railway applications

## Accessory part

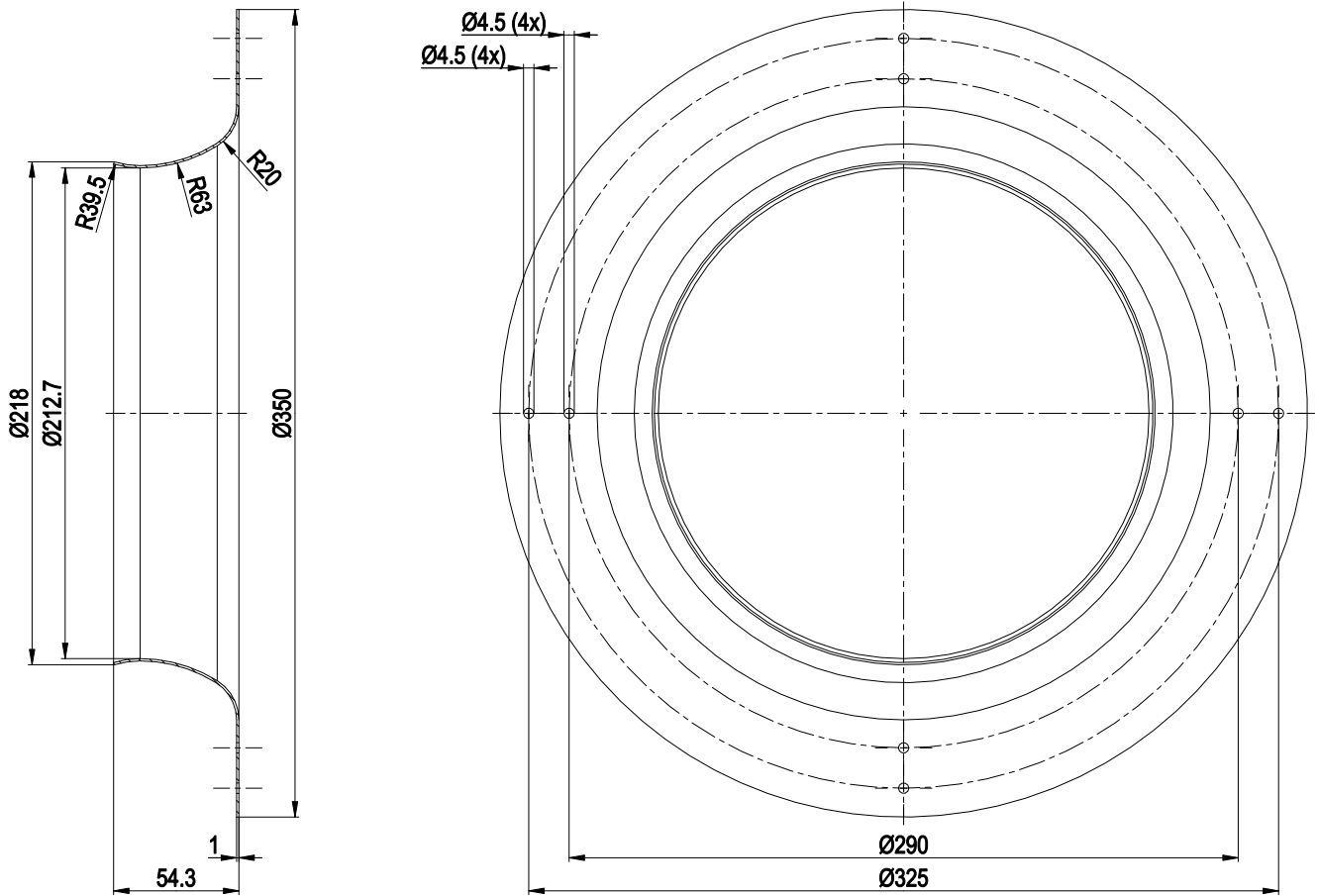

Inlet nozzle 31570-2-4013



# EC centrifugal fan - RadiPac

backward curved, single inlet

for railway applications

## Connection screen

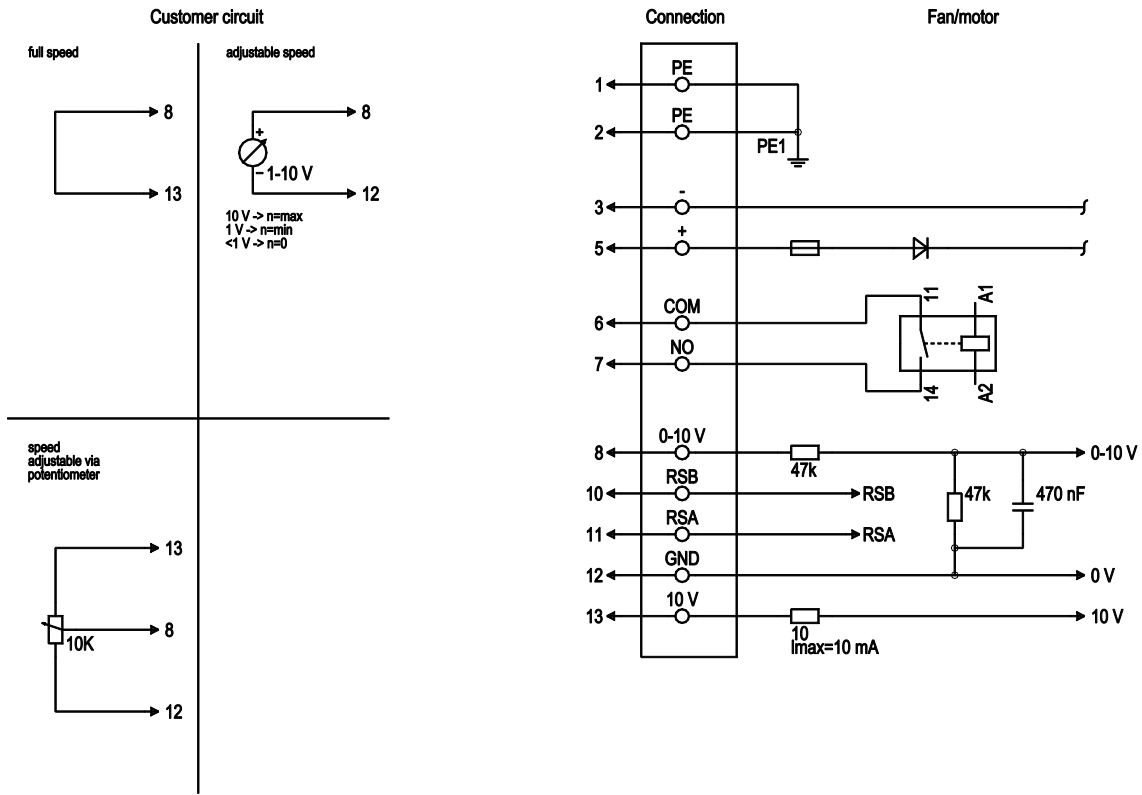

No.	Conn.	Designation	Colour	Function / assignment
1	1	PE	green/yellow	Protective earth
1	2	PE	-	not brought out via lead
1	3	-	black	Power supply, GND, see type plate for voltage range
1	5	+	brown	Power supply, see type plate for voltage range
2	6	COM	grey	Status relay, floating status contact, common connection, contact rating 250 VAC/ 30 VDC max. 2 A (AC1), min. 1 mA/5 VDC, reinforced insulation with respect to control interface, basic insulation on mains side in accordance with EN 50124-1
2	7	NO	orange	Status relay, floating status contact, make contact, contact rating 250 VAC/30 VDC max. 2 A (AC1), min. 1 mA/5 VDC, reinforced insulation with respect to control interface, basic insulation on mains side in accordance with EN 50124-1
2	8	0-10 V	yellow	Analogue input (set value) SELV, 0-10 V, R <sub>i</sub> =100kΩ, parametrisable curve
2	10	RSB	brown	RS 485 interface for MODBUS, RSB; SELV, bus termination resistor provided by customer
2	11	RSA	white	RS 485 interface for MODBUS, RSA; SELV, bus termination resistor provided by customer
2	12	GND	blue	Reference ground for control interface; SELV
2	13	+10 V	red	Fixed voltage output 10 VDC, SELV, +10 V +/-3%, max. 10 mA, short-circuit-proof, power supply for external devices (e.g. potentiometers)



## Charts: Air flow

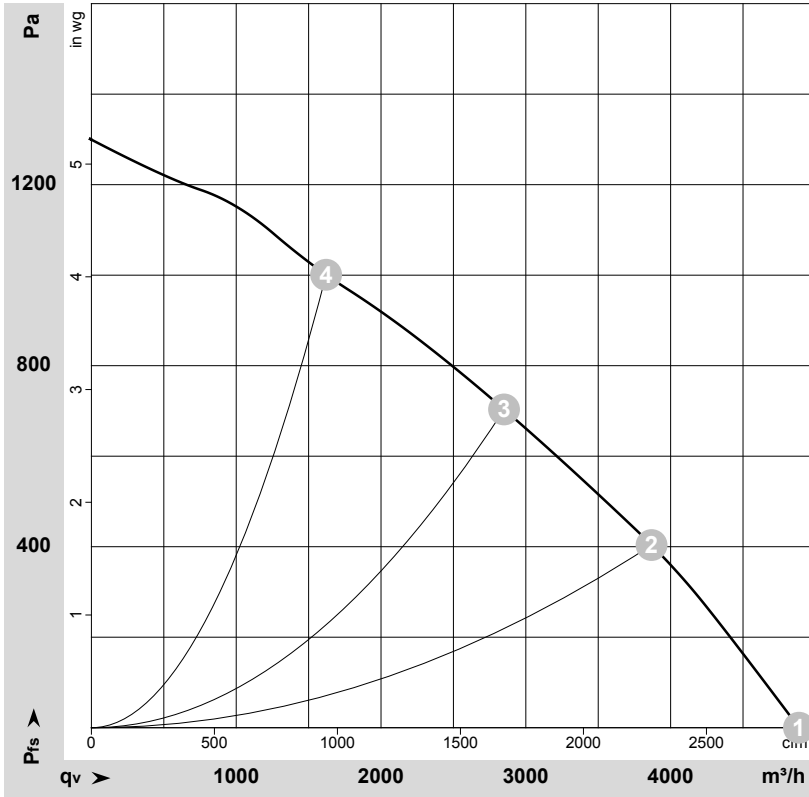

$\rho = 1.15 \text{ kg/m}^3 \pm 2 \%$

Measurement: LU-181121-1

Air performance measured as per ISO 5801 Installation category A. For detailed information on the measuring set-up, please contact ebmpapst. Suction-side noise levels: LwA measured as per ISO 13347 / LpA measured with 1m distance to fan axis. The values given are valid under the measuring conditions mentioned above and may vary according to the actual installation situation. With any deviation from the standard set-up, the specific values have to be checked and reviewed with the unit installed.

## Measured values

	U	n	P <sub>ed</sub>	I	LpA <sub>in</sub>	LwA <sub>in</sub>	q <sub>v</sub>	p <sub>fs</sub>	q <sub>v</sub>	p <sub>fs</sub>
	V	min <sup>-1</sup>	W	A	dB(A)	dB(A)	m <sup>3</sup> /h	Pa	cfm	in. wg
1	110	2915	995	9.00	80	88	4885	0	2875	0.00
2	110	2730	995	9.00	74	82	3870	400	2275	1.61
3	110	2650	995	9.00	69	77	2850	700	1675	2.81
4	110	2765	995	9.00	75	84	1620	1000	955	4.01

U = Supply voltage · n = Speed (rpm) · P<sub>ed</sub> = Power input · I = Current draw · LpA<sub>in</sub> = Sound pressure level inlet side · LwA<sub>in</sub> = Sound power level inlet side · q<sub>v</sub> = Air flow · p<sub>fs</sub> = Pressure increase

