

R3G310-AO52-15 ebmpapst Datasheet

sales@fansco.com

www.fansco.com

Limited partnership · Headquarters Mulfingen
County court Stuttgart · HRA 590344

General partner Elektrobau Mulfingen GmbH · Headquarters Mulfingen
County court Stuttgart · HRB 590142



Nominal data

| | | |
|--------------------------|-------------------|------------|
| Type | R3G310-AO52-15 | |
| Motor | M3G074-CF | |
| Phase | | 1~ |
| Nominal voltage | VAC | 230 |
| Nominal voltage range | VAC | 200 .. 277 |
| Frequency | Hz | 50/60 |
| Type of data definition | | fa |
| Speed | min ⁻¹ | 1925 |
| Power input | W | 150 |
| Current draw | A | 1.1 |
| Min. ambient temperature | °C | -25 |
| Max. ambient temperature | °C | 60 |

ml = Max. load · me = Max. efficiency · fa = Running at free air · cs = Customer specs · cu = Customer unit
Subject to alterations

Data according to ErP directive

| | |
|-----------------------|--------|
| Installation category | A |
| Efficiency category | Static |
| Variable speed drive | Yes |
| Specific ratio* | 1.00 |

* Specific ratio = $1 + p_{fs} / 100\,000\text{ Pa}$

| | | Actual | Request 2013 | Request 2015 |
|--------------------------------|-------------------|--------|--------------|--------------|
| Overall efficiency η_{es} | % | 59.8 | 39.4 | 43.4 |
| Efficiency grade N | | 78.4 | 58 | 62 |
| Power input P_{ed} | kW | 0.17 | | |
| Air flow q_v | m ³ /h | 1300 | | |
| Pressure increase p_{fs} | Pa | 250 | | |
| Speed n | min ⁻¹ | 1705 | | |

Data definition with optimum efficiency.
The ErP data is determined using a motor-impeller combination in a standardised measurement configuration.



Technical features

| | |
|--|--|
| Mass | 3.1 kg |
| Size | 310 mm |
| Surface of rotor | Coated in black |
| Material of electronics housing | Die-cast aluminium |
| Material of impeller | Aluminium sheet |
| Number of blades | 6 |
| Direction of rotation | Clockwise, seen on rotor |
| Type of protection | IP 44 |
| Insulation class | "B" |
| Humidity class | F3-1 |
| Max. permissible ambient motor temp. (transp./ storage) | + 80 °C |
| Min. permissible ambient motor temp. (transp./storage) | - 40 °C |
| Mounting position | Any |
| Condensate discharge holes | None |
| Operation mode | S1 |
| Motor bearing | Ball bearing |
| Technical features | <ul style="list-style-type: none"> - Tach output - Motor current limit - Soft start - Control input 0-10 VDC / PWM - Control interface with SELV potential safely disconnected from the mains - Over-temperature protected electronics / motor |
| EMC interference immunity | Acc. to EN 61000-6-2 (industrial environment) |
| EMC harmonics | Acc. to EN 61000-3-2/3 |
| EMC interference emission | Acc. to EN 61000-6-3 (household environment) |
| Touch current acc. IEC 60990 (measuring network Fig. 4, TN system) | <= 3.5 mA |
| Motor protection | Thermal overload protector (TOP) wired internally |
| Cable exit | Variable |
| Protection class | I (if protective earth is connected by customer) |
| Product conforming to standard | EN 60335-1; CE |
| Approval | UL 2111; CSA C22.2 Nr.77 |

EC centrifugal fan

backward curved, single inlet

Product drawing

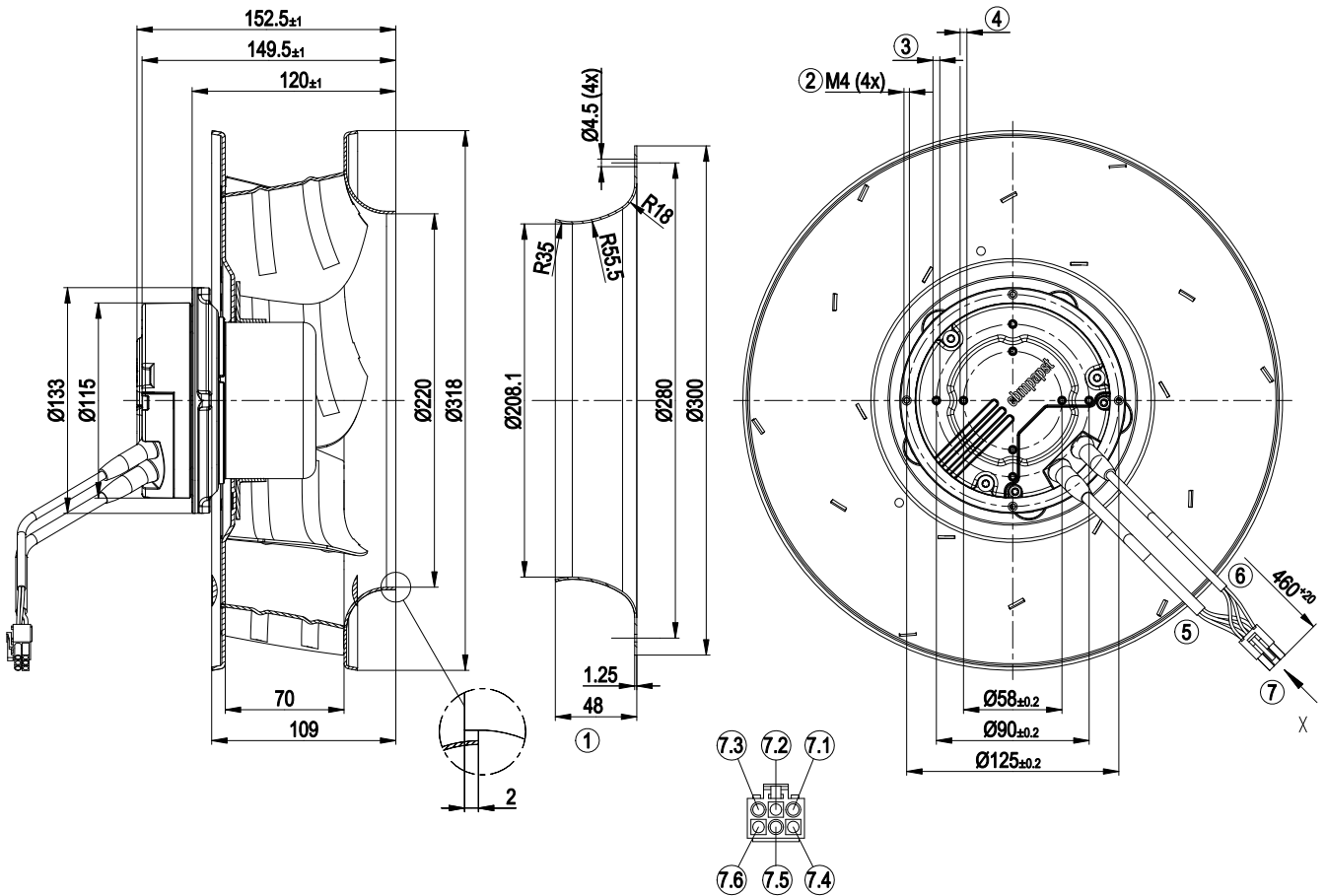

| | |
|-----|---|
| 1 | Accessory part: inlet nozzle 31050-2-4013 not included in scope of delivery, other inlet nozzles on request |
| 2 | Depth of screw 8-10 mm; tightening torque 2.5±0.2 Nm; gluing the screws is recommended |
| 3 | Pilot hole prepared for self-tapping screw M4, depth of screw max. 6 mm |
| 4 | Pilot hole prepared for self-tapping screw M4, depth of screw max. 8 mm |
| 5 | Connection line PVC AWG18, 3x female connector JST SLF-41T-P1.3E crimped |
| 6 | Connection line PVC AWG22, 3x female connector JST SLF-01T-P1.3E crimped |
| 7 | Connector housing JST ELP-06V |
| 7.1 | Tach (white) |
| 7.2 | 0-10 V / PWM (yellow) |
| 7.3 | - (blue) |
| 7.4 | L (black) |
| 7.5 | N (blue) |
| 7.6 | PE (green/yellow) |



Connection screen

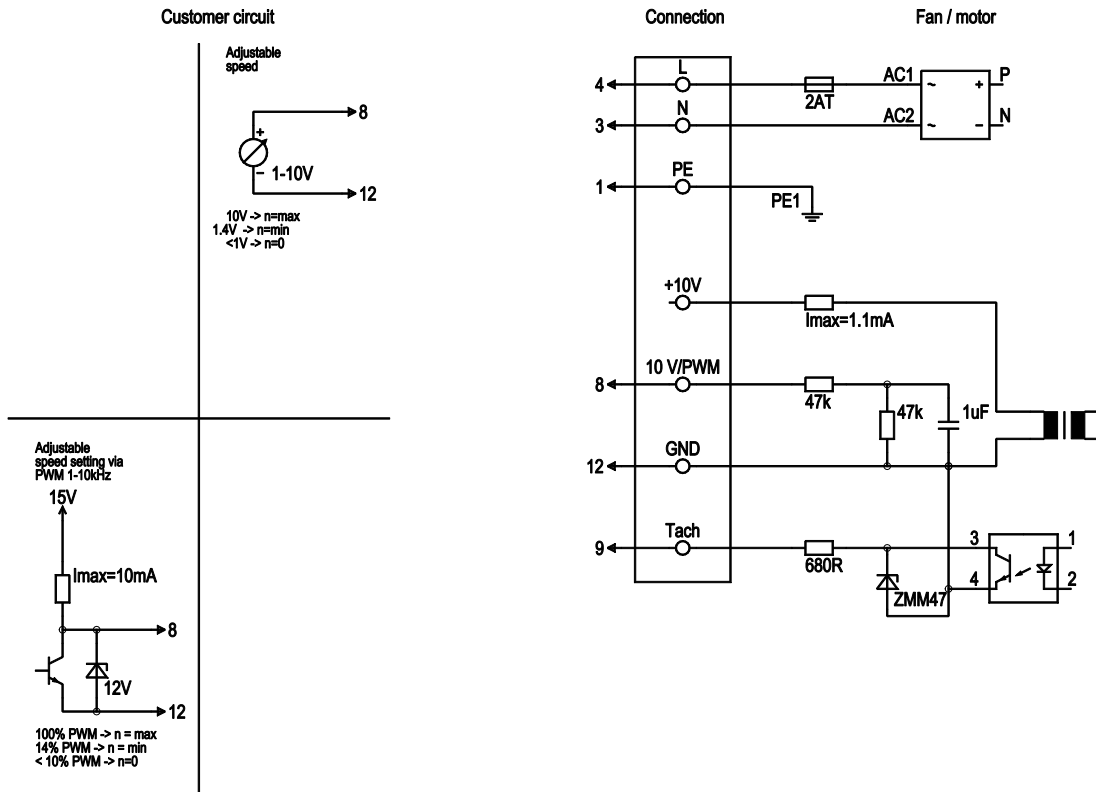

Charts: Air flow 50 Hz



Measurement: LU-69203
 Measurement: LU-67778
 Measurement: LU-67779
 Measurement: LU-67780

Air performance measured as per ISO 5801 Installation category A. For detailed information on the measuring set-up, please contact ebm-papst. Suction-side noise levels: L_{wA} measured as per ISO 13347 / L_{pA} measured with 1m distance to fan axis. The values given are valid under the measuring conditions mentioned above and may vary according to the actual installation situation. With any deviation from the standard set-up, the specific values have to be checked and reviewed with the unit installed.

Measured values

| | U | f | n | P _{ed} | I | qv | p _{fs} |
|----|-----|----|-------------------|-----------------|------|-------------------|-----------------|
| | V | Hz | min ⁻¹ | W | A | m ³ /h | Pa |
| 1 | 230 | 50 | 1925 | 150 | 1.10 | 2245 | 0 |
| 2 | 230 | 50 | 1815 | 174 | 1.29 | 1860 | 140 |
| 3 | 230 | 50 | 1705 | 172 | 1.27 | 1310 | 260 |
| 4 | 230 | 50 | 1775 | 175 | 1.29 | 730 | 380 |
| 5 | 230 | 50 | 1670 | 100 | 0.75 | 1995 | 0 |
| 6 | 230 | 50 | 1610 | 131 | 0.96 | 1665 | 112 |
| 7 | 230 | 50 | 1585 | 140 | 1.01 | 1220 | 226 |
| 8 | 230 | 50 | 1610 | 135 | 0.99 | 665 | 316 |
| 9 | 230 | 50 | 1395 | 60 | 0.47 | 1655 | 0 |
| 10 | 230 | 50 | 1355 | 78 | 0.59 | 1395 | 79 |
| 11 | 230 | 50 | 1340 | 85 | 0.64 | 1030 | 161 |
| 12 | 230 | 50 | 1350 | 82 | 0.61 | 560 | 224 |
| 13 | 230 | 50 | 1025 | 28 | 0.23 | 1210 | 0 |
| 14 | 230 | 50 | 1005 | 36 | 0.28 | 1030 | 43 |
| 15 | 230 | 50 | 990 | 40 | 0.31 | 760 | 87 |
| 16 | 230 | 50 | 1000 | 38 | 0.30 | 410 | 122 |

U = Supply voltage · f = Frequency · n = Speed · P_{ed} = Power input · I = Current draw · qv = Air flow · p_{fs} = Pressure increase

