

R3G310-AN43-77 ebmpapst Datasheet

sales@fansco.com

www.fansco.com

Limited partnership · Headquarters Mulfingen

Amtsgericht (court of registration) Stuttgart · HRA 590344

General partner Elektrobau Mulfingen GmbH · Headquarters Mulfingen

Amtsgericht (court of registration) Stuttgart · HRB 590142

Nominal data

Type	R3G310-AN43-77	
Motor	M3G084-FA	
Phase		1~
Nominal voltage	VAC	230
Nominal voltage range	VAC	200 .. 277
Frequency	Hz	50/60
Method of obtaining data		ml
Speed (rpm)	min ⁻¹	2435
Power consumption	W	470
Current draw	A	3.0
Min. ambient temperature	°C	-25
Max. ambient temperature	°C	45

ml = Max. load · me = Max. efficiency · fa = Free air · cs = Customer specification · ce = Customer equipment
Subject to change

Data according to Commission Regulation (EU) 327/2011 (EN 17166)

		Actual	Req. 2015			
01 Overall efficiency η_{es}	%	60.7	48	09 Power consumption P_{ed}	kW	0.46
02 Measurement category		A		09 Air flow q_v	m ³ /h	1810
03 Efficiency category		Static		09 Pressure increase p_{fs}	Pa	507
04 Efficiency grade N		74.7	62	10 Speed (rpm) n	min ⁻¹	2455
05 Variable speed drive		Yes		11 Specific ratio [*]		1.01

Data obtained at optimum efficiency level.

The ErP data is determined using a motor-impeller combination in a standardized measurement setup.

^{*} Specific ratio = $1 + p_{fs} / 100\,000\text{ Pa}$

LU-112311



Technical description

Weight	5.7 kg
Size	310 mm
Motor size	84
Rotor surface	Painted black
Electronics housing material	Die-cast aluminum
Impeller material	Sheet aluminum
Number of blades	6
Direction of rotation	Clockwise, viewed toward rotor
Degree of protection	IP54
Insulation class	"B"
Moisture (F) / Environmental (H) protection class	H1
Max. permitted ambient temp. for motor (transport/storage)	+80 °C
Min. permitted ambient temp. for motor (transport/storage)	-40 °C
Installation position	Shaft horizontal or rotor on top; rotor on bottom on request
Condensation drainage holes	None
Mode	S1
Motor bearing	Ball bearing
Technical features	<ul style="list-style-type: none"> - Output 10 VDC, max. 1.1 mA - Alarm relay - Motor current limitation - PFC, passive - Soft start - Control input 0-10 VDC / PWM - Control interface with SELV potential safely disconnected from the mains - Thermal overload protection for electronics/motor - Line undervoltage detection
Touch current according to IEC 60990 (measuring circuit Fig. 4, TN system)	<= 3.5 mA
Motor protection	Thermal overload protector (TOP) internally connected
With cable	Variable
Protection class	I (with customer connection of protective earth)
Conformity with standards	EN 61800-5-1; CE
Approval	UL 1004-3 + 60730-1; CSA C22.2 No. 77 + CAN/CSA-E60730-1

Product drawing

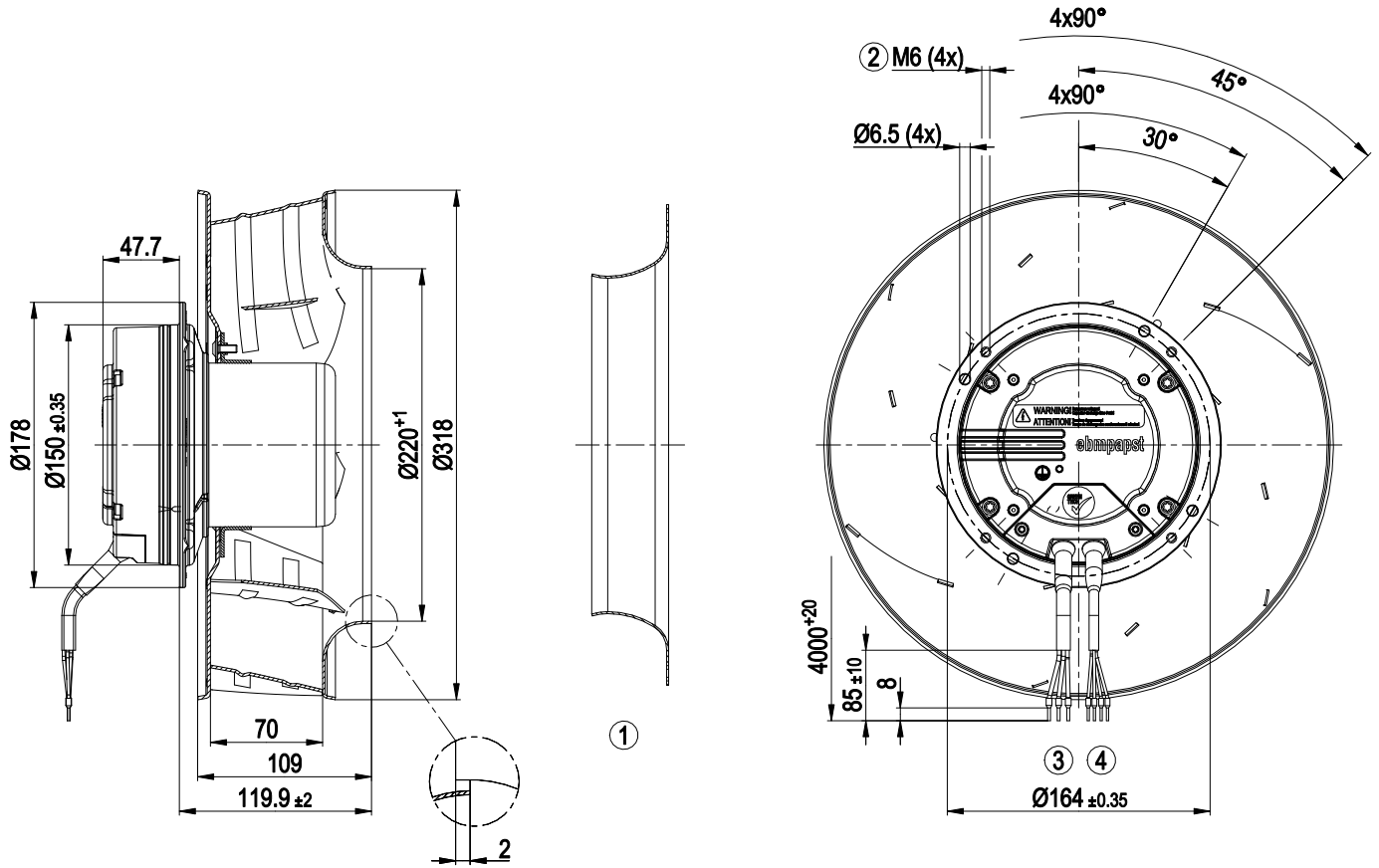

1	Accessory part: inlet ring 31050-2-4013 not included in scope of delivery
2	Max. clearance for screw 10 mm
3	Cable PVC AWG18 5x wire-end ferrule
4	Cable PVC AWG22 3x wire-end ferrule



Accessory part

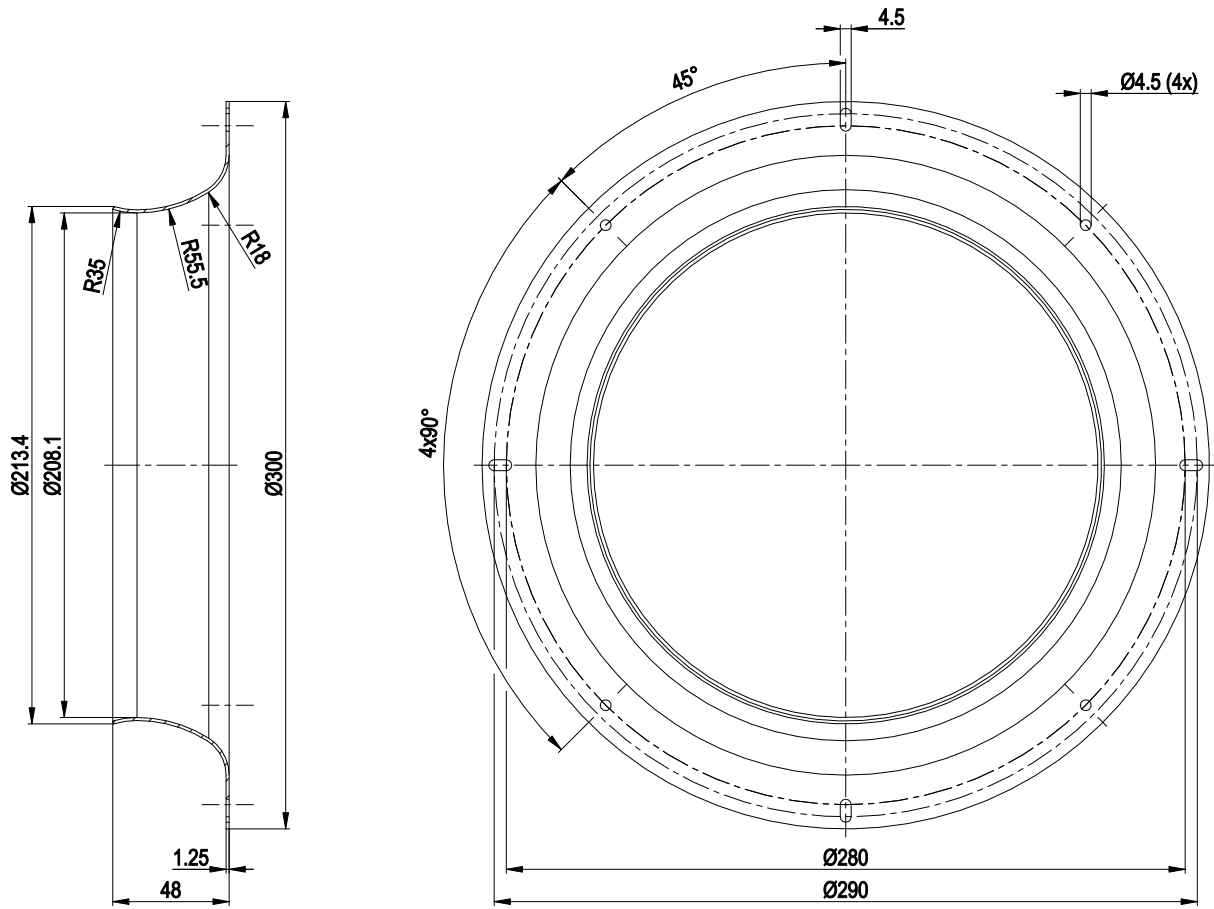

Inlet ring 31050-2-4013

EC centrifugal fan

backward-curved, single-intake

Connection diagram

Customer circuit

Application notes for various control options

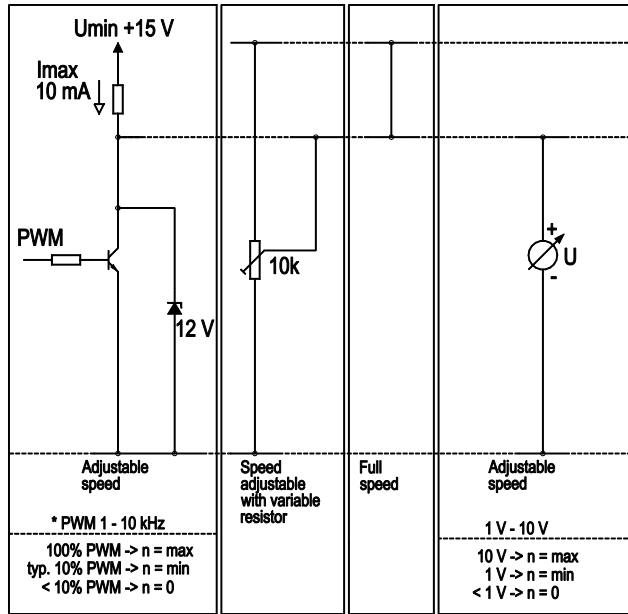

Connection

Fan / Motor

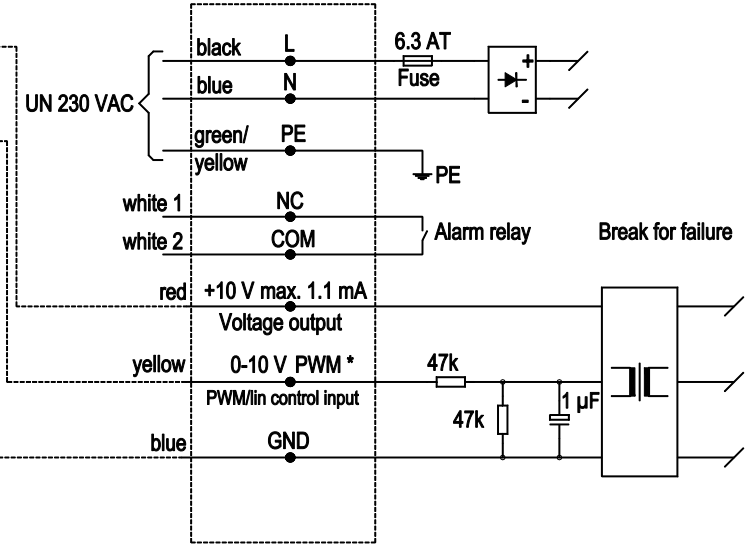

Curves: Air performance 50 Hz

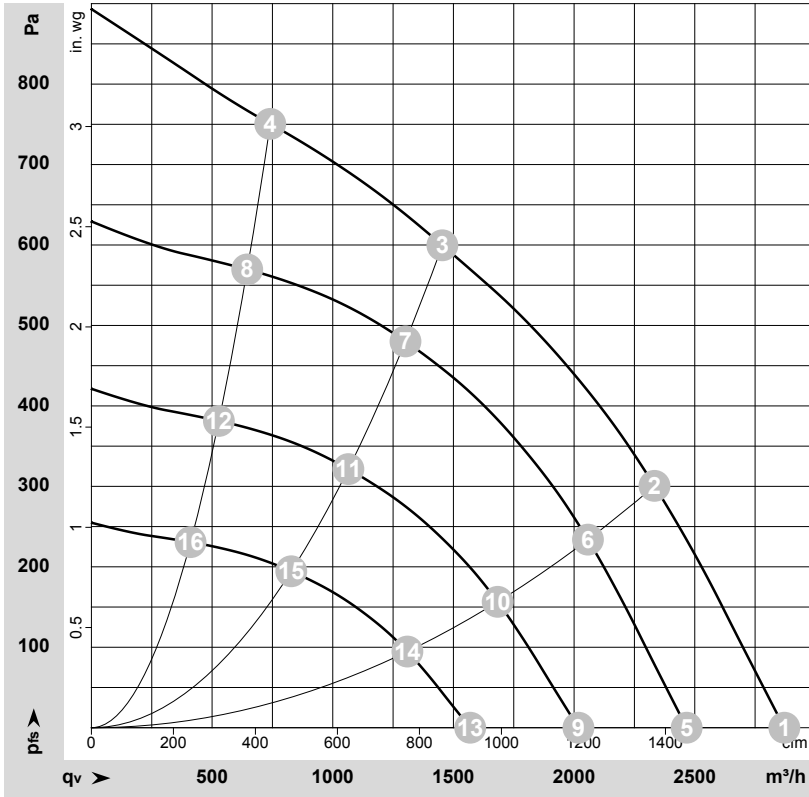

$\rho = 1.15 \text{ kg/m}^3 \pm 2 \%$

Measurement: LU-112311-1

Air performance measured according to ISO 5801 installation category A. For detailed information on the measurement setup, contact ebmpapst. Intake sound level: Sound power level according to ISO 13347 / sound pressure level measured at 1 m distance from fan axis. The values given are valid under the specified measuring conditions and may vary due to conditions of installation. For deviations from the standard configuration, the parameters have to be checked on the installed unit.

Measured values

	Wired	U	f	n	P _{ed}	I	q _v	P _{fs}	q _v	P _{fs}
		V	Hz	min ⁻¹	W	A	m ³ /h	Pa	cfm	in. wg
1	1~	230	50	2560	356	2.31	2870	0	1690	0.00
2	1~	230	50	2495	438	2.83	2335	300	1375	1.20
3	1~	230	50	2435	470	3.00	1455	600	855	2.41
4	1~	230	50	2525	403	2.61	740	750	435	3.01
5	1~	230	50	2200	226	1.46	2465	0	1450	0.00
6	1~	230	50	2200	301	1.94	2055	236	1210	0.95
7	1~	230	50	2200	334	2.17	1300	481	765	1.93
8	1~	230	50	2200	267	1.73	645	570	380	2.29
9	1~	230	50	1800	124	0.80	2020	0	1190	0.00
10	1~	230	50	1800	165	1.06	1685	158	990	0.63
11	1~	230	50	1800	183	1.19	1065	322	625	1.29
12	1~	230	50	1800	146	0.95	530	381	310	1.53
13	1~	230	50	1400	58	0.38	1570	0	925	0.00
14	1~	230	50	1400	78	0.50	1310	95	770	0.38
15	1~	230	50	1400	86	0.56	830	195	485	0.78
16	1~	230	50	1400	69	0.44	410	231	240	0.93

Wired = Wiring · U = Voltage · f = Frequency · n = Speed (rpm) · P_{ed} = Power consumption · I = Current draw · q_v = Air flow · p_{fs} = Pressure increase

