

R3G310-AN43-75 ebmpapst Datasheet

sales@fansco.com

www.fansco.com

Limited partnership · Headquarters Mulfingen

Amtsgericht (court of registration) Stuttgart · HRA 590344

General partner Elektrobau Mulfingen GmbH · Headquarters Mulfingen

Amtsgericht (court of registration) Stuttgart · HRB 590142



## Nominal data

Type	R3G310-AN43-75	
Motor	M3G084-FA	
Phase		1~
Nominal voltage	VAC	230
Nominal voltage range	VAC	200 .. 277
Frequency	Hz	50/60
Method of obtaining data		ml
Speed (rpm)	min <sup>-1</sup>	2435
Power consumption	W	470
Current draw	A	3.0
Min. ambient temperature	°C	-25
Max. ambient temperature	°C	45

ml = Max. load · me = Max. efficiency · fa = Free air · cs = Customer specification · ce = Customer equipment  
Subject to change

## Data according to ErP Directive

		Actual	Req. 2015			
01 Overall efficiency $\eta_{es}$	%	60.6	48	09 Power consumption $P_{ed}$	kW	0.46
02 Measurement category		A		09 Air flow $q_v$	m <sup>3</sup> /h	1810
03 Efficiency category		Static		09 Pressure increase $p_{fs}$	Pa	507
04 Efficiency grade N		74.6	62	10 Speed (rpm) n	min <sup>-1</sup>	2455
05 Variable speed drive		Yes		11 Specific ratio*		1.01

Data obtained at optimum efficiency level.

The ErP data is determined using a motor-impeller combination in a standardized measurement setup.

\* Specific ratio =  $1 + p_{fs} / 100\,000\text{ Pa}$

LU-112311



## Technical description

Weight	5.2 kg
Fan size	310 mm
Rotor surface	Painted black
Electronics housing material	Die-cast aluminum
Impeller material	Sheet aluminum
Number of blades	6
Direction of rotation	Clockwise, viewed toward rotor
Degree of protection	IP54
Insulation class	"B"
Moisture (F) / Environmental (H) protection class	F3-1
Max. permitted ambient temp. for motor (transport/storage)	+80 °C
Min. permitted ambient temp. for motor (transport/storage)	-40 °C
Installation position	Shaft horizontal or rotor on top; rotor on bottom on request
Condensation drainage holes	None
Mode	S1
Motor bearing	Ball bearing
Technical features	<ul style="list-style-type: none"> <li>- Output 10 VDC, max. 1.1 mA</li> <li>- Alarm relay</li> <li>- Motor current limitation</li> <li>- Soft start</li> <li>- Control input 0-10 VDC / PWM</li> <li>- Control interface with SELV potential safely disconnected from the mains</li> <li>- Thermal overload protection for electronics/motor</li> <li>- Line undervoltage detection</li> </ul>
EMC immunity to interference	According to EN 61000-6-2 (industrial environment)
EMC interference emission	According to EN 61000-6-3 (household environment)
Touch current according to IEC 60990 (measuring circuit Fig. 4, TN system)	<= 3.5 mA
Motor protection	Thermal overload protector (TOP) internally connected
With cable	Variable
Protection class	I (with customer connection of protective earth)
Conformity with standards	EN 61800-5-1; CE
Approval	CSA C22.2 No. 77; UL 2111

Product drawing

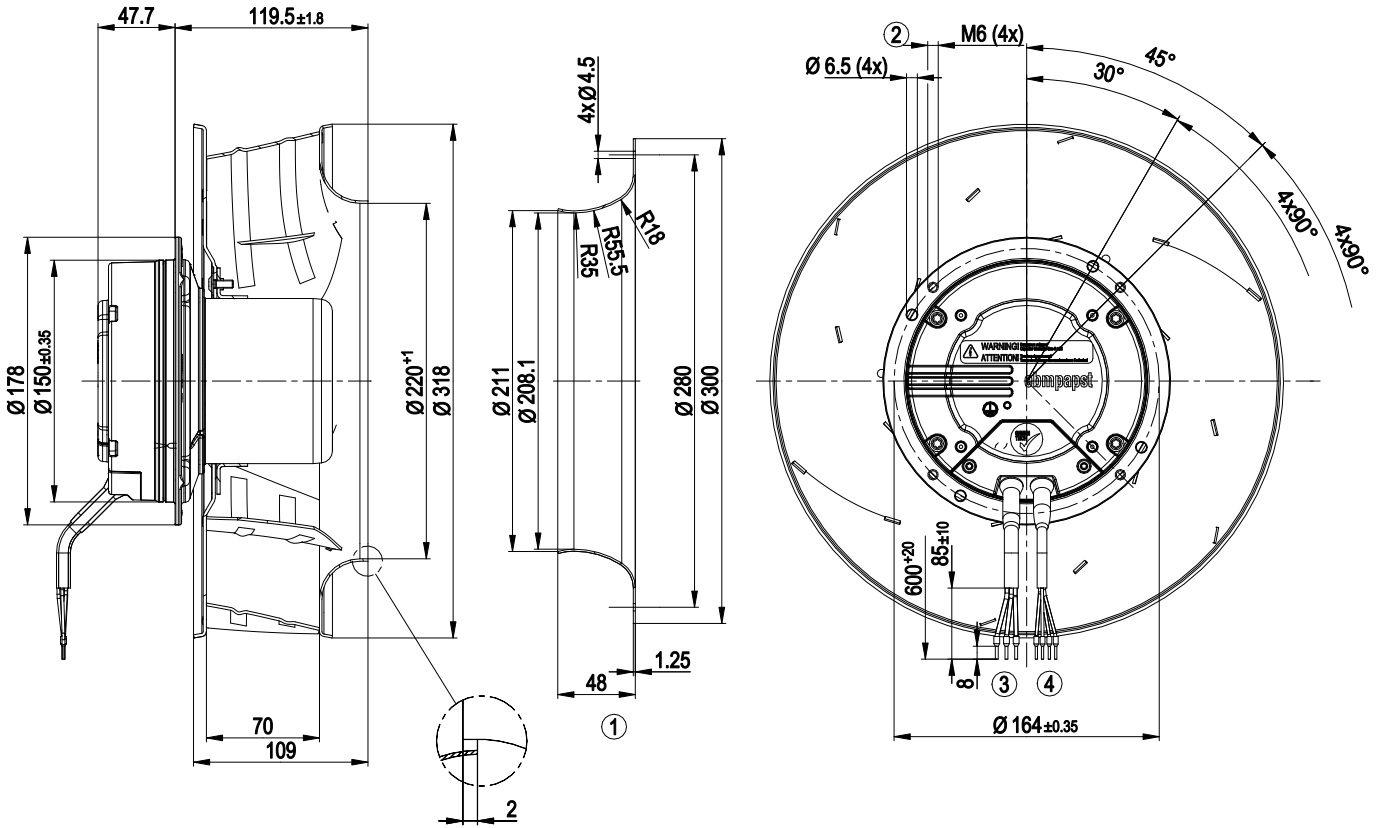

1	Accessory part: inlet ring 31050-2-4013 not included in scope of delivery
2	Clearance for screw 8 - 10 mm
3	Cable silicone 5x 1.0 mm <sup>2</sup> ; 5x crimped ferrules
4	Cable silicone 3x 0.34 mm <sup>2</sup> ; 3x crimped ferrules



## Connection diagram

Customer circuit

Application notes for various control options

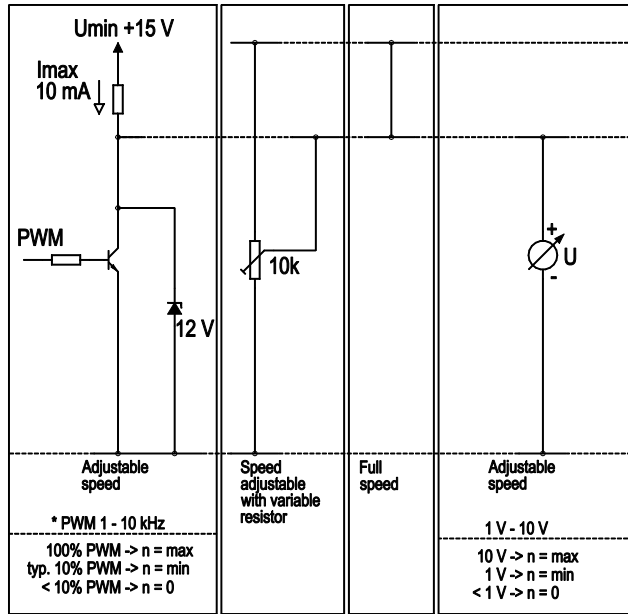

Connection

Fan / Motor

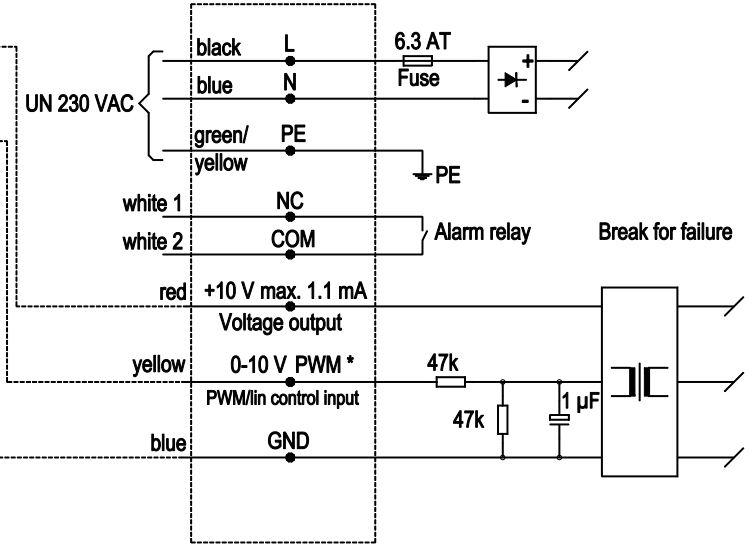

## Curves: Air performance 50 Hz

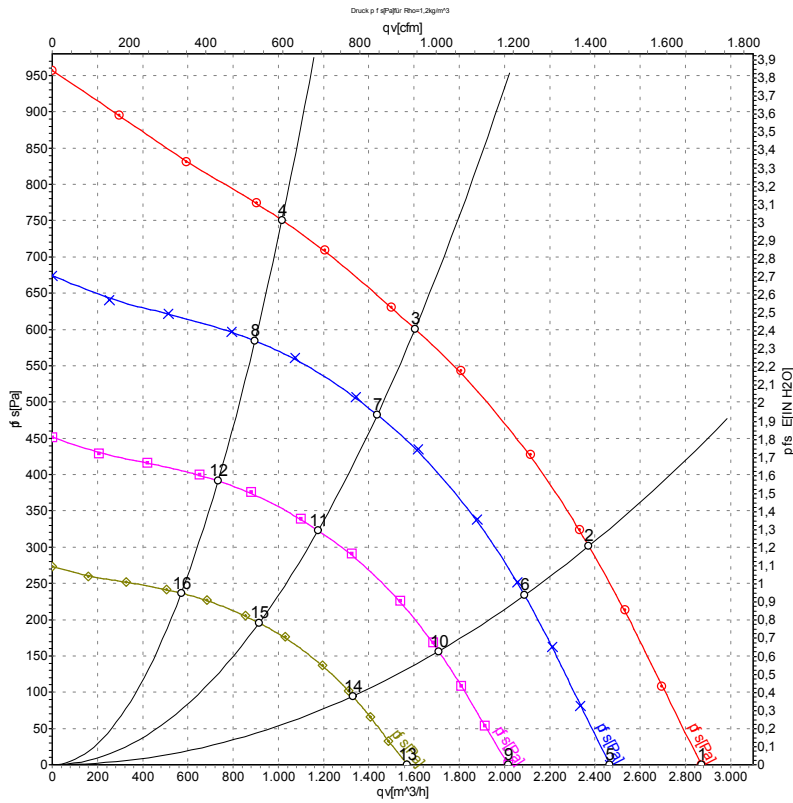

Measurement: LU-112311-1

Air performance measured according to ISO 5801 installation category A. For detailed information on the measurement setup, contact ebm-papst. Intake sound level: Sound power level according to ISO 13347 / sound pressure level measured at 1 m distance from fan axis. The values given are valid under the specified measuring conditions and may vary due to conditions of installation. For deviations from the standard configuration, the parameters have to be checked on the installed unit.

## Measured values

	U	f	n	P <sub>ed</sub>	I	qv	p <sub>is</sub>	qv	p <sub>is</sub>
	V	Hz	min <sup>-1</sup>	W	A	m <sup>3</sup> /h	Pa	CFM	inH2O
1	230	50	2560	356	2.31	2870	0	1690	0.00
2	230	50	2500	432	2.79	2375	300	1395	1.20
3	230	50	2435	470	3.00	1605	600	945	2.41
4	230	50	2495	437	2.84	1015	750	600	3.01
5	230	50	2200	226	1.46	2465	0	1450	0.00
6	230	50	2200	295	1.91	2090	234	1230	0.94
7	230	50	2200	336	2.18	1440	482	845	1.94
8	230	50	2200	301	1.95	895	584	525	2.34
9	230	50	1800	124	0.80	2020	0	1190	0.00
10	230	50	1800	162	1.04	1710	157	1005	0.63
11	230	50	1800	184	1.19	1175	323	690	1.30
12	230	50	1800	165	1.07	735	391	430	1.57
13	230	50	1400	58	0.38	1570	0	925	0.00
14	230	50	1400	76	0.49	1330	95	780	0.38
15	230	50	1400	87	0.56	915	195	540	0.78
16	230	50	1400	77	0.50	570	237	335	0.95

U = Power supply · f = Frequency · n = Speed (rpm) · P<sub>ed</sub> = Power consumption · I = Current draw · qv = Air flow · p<sub>is</sub> = Pressure increase

