

R3G310-AL47-79

# EC centrifugal fan

backward-curved, single-intake



R3G310-AL47-79 ebmpapst Datasheet

[sales@fansco.com](mailto:sales@fansco.com)

[www.fansco.com](http://www.fansco.com)

Limited partnership · Headquarters Mulfingen  
Amtsgericht (court of registration) Stuttgart · HRA 590344

General partner Elektrobau Mulfingen GmbH · Headquarters Mulfingen  
Amtsgericht (court of registration) Stuttgart · HRB 590142



## Nominal data

Type	R3G310-AL47-79	
Motor	M3G084-FA	
Phase		1~
Nominal voltage	VAC	230
Nominal voltage range	VAC	200 .. 277
Frequency	Hz	50/60
Method of obtaining data		ml
Speed (rpm)	min <sup>-1</sup>	2160
Power consumption	W	450
Current draw	A	2.9
Min. ambient temperature	°C	-25
Max. ambient temperature	°C	45

ml = Max. load · me = Max. efficiency · fa = Free air · cs = Customer specification · ce = Customer equipment  
Subject to change

## Data according to ErP Directive

		Actual	Req. 2015			
01 Overall efficiency $\eta_{es}$	%	58.9	47.9	09 Power consumption $P_{ed}$	kW	0.45
02 Measurement category		A		09 Air flow $q_v$	m <sup>3</sup> /h	2105
03 Efficiency category		Static		09 Pressure increase $p_{fs}$	Pa	409
04 Efficiency grade N		73	62	10 Speed (rpm) $n$	min <sup>-1</sup>	2160
05 Variable speed drive		Yes		11 Specific ratio*		1.00

Data obtained at optimum efficiency level.

The ErP data is determined using a motor-impeller combination in a standardized measurement setup.

\* Specific ratio =  $1 + p_{fs} / 100\,000\text{ Pa}$

LU-135169



## Technical description

Weight	5.32 kg
Fan size	310 mm
Rotor surface	Painted black
Electronics housing material	Die-cast aluminum
Impeller material	Sheet aluminum
Number of blades	6
Direction of rotation	Clockwise, viewed toward rotor
Degree of protection	IP54
Insulation class	"B"
Moisture (F) / Environmental (H) protection class	F3-1
Max. permitted ambient temp. for motor (transport/storage)	+80 °C
Min. permitted ambient temp. for motor (transport/storage)	-40 °C
Installation position	Shaft horizontal or rotor on top; rotor on bottom on request
Condensation drainage holes	None
Mode	S1
Motor bearing	Ball bearing
Technical features	<ul style="list-style-type: none"> <li>- Output 10 VDC, max. 1.1 mA</li> <li>- Tach output</li> <li>- Motor current limitation</li> <li>- Soft start</li> <li>- Control input 0-10 VDC / PWM</li> <li>- Control interface with SELV potential safely disconnected from the mains</li> <li>- Thermal overload protection for electronics/motor</li> <li>- Line undervoltage detection</li> </ul>
EMC immunity to interference	According to EN 61000-6-2 (industrial environment)
EMC circuit feedback	According to EN 61000-3-2/3
EMC interference emission	According to EN 61000-6-3 (household environment)
Touch current according to IEC 60990 (measuring circuit Fig. 4, TN system)	<= 3.5 mA
Motor protection	Thermal overload protector (TOP) internally connected
With cable	Variable
Protection class	I (with customer connection of protective earth)
Conformity with standards	EN 61800-5-1; CE
Approval	CSA C22.2 No. 77; UL 2111

Product drawing

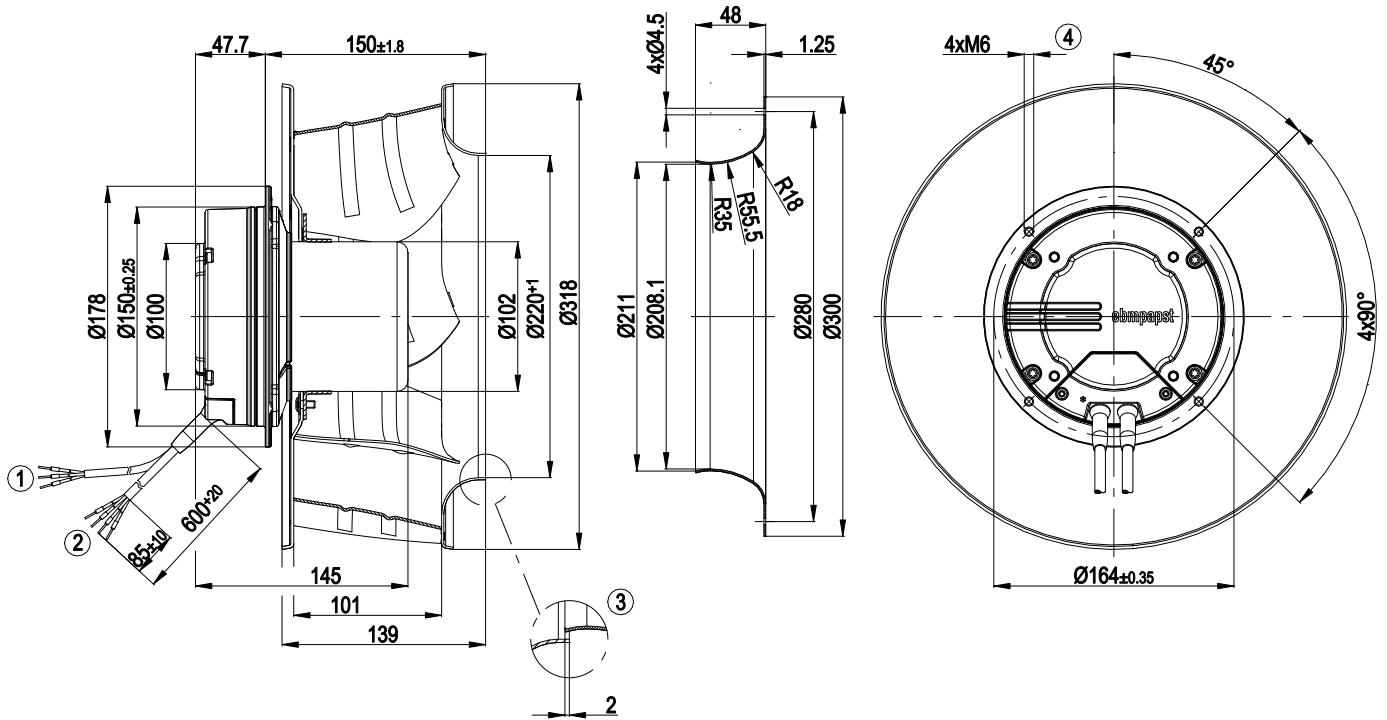

1	Cable PVC AWG18, 3x crimped ferrules
2	Cable PVC AWG22, 4x crimped ferrules
3	Accessory part: inlet ring 31050-2-4013 not included in scope of delivery
4	Clearance for screw 8 - 10 mm



## Connection diagram

### Customer circuit

Application notes for various control options

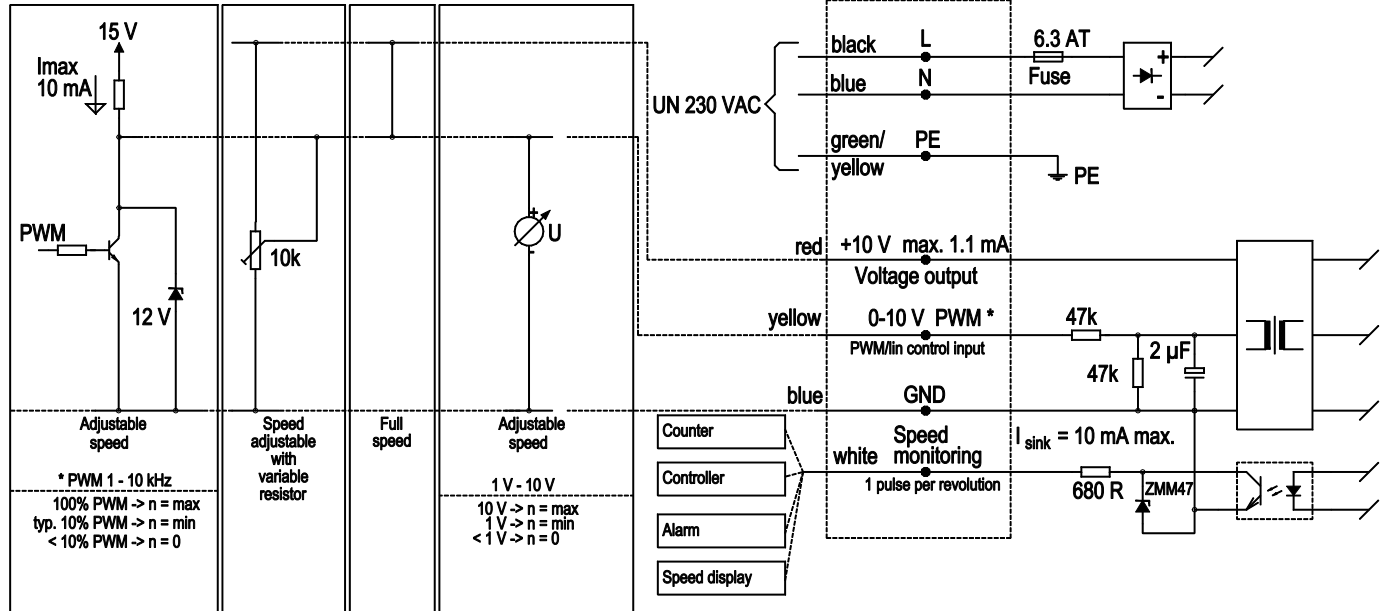

## Curves: Air performance 50 Hz

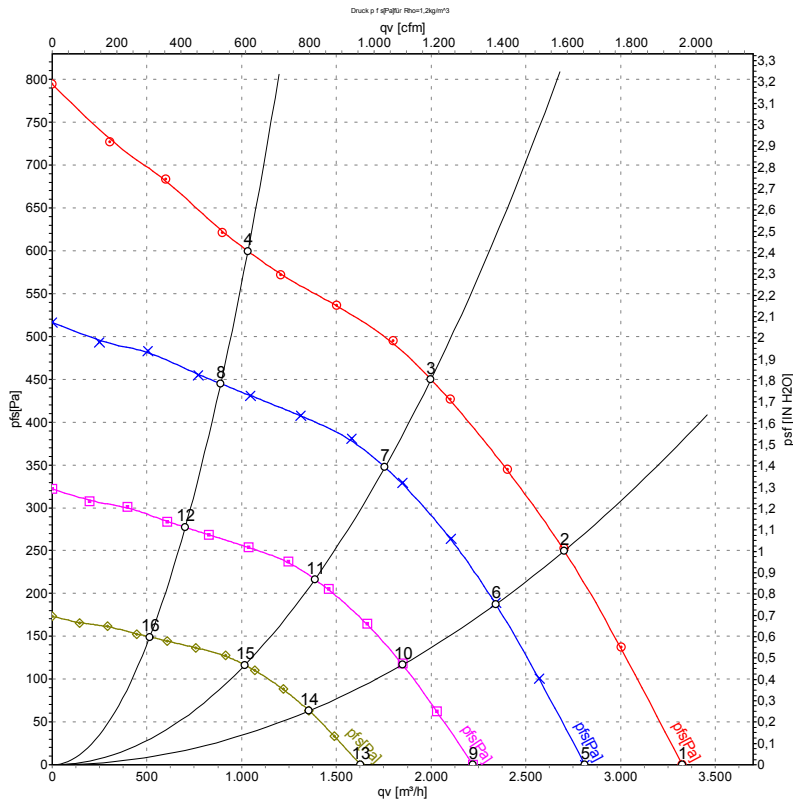

Measurement: LU-135169-1

Air performance measured according to ISO 5801 installation category A. For detailed information on the measurement setup, contact ebmpapst. Intake sound level: Sound power level according to ISO 13347 / sound pressure level measured at 1 m distance from fan axis. The values given are valid under the specified measuring conditions and may vary due to conditions of installation. For deviations from the standard configuration, the parameters have to be checked on the installed unit.

## Measured values

	U	f	n	P <sub>ed</sub>	I	LpA <sub>in</sub>	LwA <sub>in</sub>	qv	p <sub>fs</sub>	qv	p <sub>fs</sub>
	V	Hz	min <sup>-1</sup>	W	A	dB(A)	dB(A)	m³/h	Pa	CFM	inH2O
1	230	50	2245	338	2.21	74	82	3325	0	1960	0.00
2	230	50	2195	408	2.67	68	76	2705	250	1590	1.00
3	230	50	2160	450	2.90	65	74	2000	450	1175	1.81
4	230	50	2205	400	2.64	70	78	1030	600	605	2.41
5	230	50	1900	204	1.33	70	78	2810	0	1655	0.00
6	230	50	1900	265	1.73	64	73	2340	189	1380	0.76
7	230	50	1900	305	2.00	62	70	1755	348	1035	1.40
8	230	50	1900	256	1.69	66	75	890	445	525	1.79
9	230	50	1500	101	0.66	64	72	2220	0	1305	0.00
10	230	50	1500	130	0.85	58	67	1850	118	1090	0.47
11	230	50	1500	150	0.98	56	65	1385	217	815	0.87
12	230	50	1500	126	0.83	60	69	700	277	415	1.11
13	230	50	1100	40	0.26	56	64	1630	0	960	0.00
14	230	50	1100	51	0.34	51	59	1355	64	800	0.26
15	230	50	1100	59	0.39	48	57	1015	116	600	0.47
16	230	50	1100	50	0.33	52	61	515	149	305	0.60

U = Power supply · f = Frequency · n = Speed (rpm) · P<sub>ed</sub> = Power consumption · I = Current draw · LpA<sub>in</sub> = Sound pressure level intake side · LwA<sub>in</sub> = Sound power level intake side  
 qv = Air flow · p<sub>fs</sub> = Pressure increase

