

R3G310-8317077391

# EC centrifugal fan

backward-curved, single-intake



**ebm-papst ventilator (Shanghai)Co.,Ltd.**

No.418, Hua jing Road, Wai Gao qiao Free Trade Zone, Pudong

R3G310-8317077391 ebmpapst Datasheet

sales@fansco.com

www.fansco.com

## Nominal data

<b>Type</b>	R3G310-8317077391	
<b>Motor</b>	M3G084-FA	
Phase		1~
Nominal voltage	VAC	230
Nominal voltage range	VAC	200 .. 277
Frequency	Hz	50/60
Method of obtaining data		ml
Speed (rpm)	min <sup>-1</sup>	1745
Power consumption	W	400
Current draw	A	1.7
Min. ambient temperature	°C	-25
Max. ambient temperature	°C	30

ml = Max. load · me = Max. efficiency · fa = Free air · cs = Customer specification · ce = Customer equipment  
Subject to change



### Technical description

<b>Weight</b>	5.5 kg
<b>Fan size</b>	310 mm
<b>Rotor surface</b>	Painted black
<b>Electronics housing material</b>	Die-cast aluminum
<b>Impeller material</b>	Sheet aluminum
<b>Number of blades</b>	6
<b>Direction of rotation</b>	Clockwise, viewed toward rotor
<b>Degree of protection</b>	IP20
<b>Insulation class</b>	"B"
<b>Moisture (F) / Environmental (H) protection class</b>	F0
<b>Max. permitted ambient temp. for motor (transport/storage)</b>	+ 80 °C
<b>Min. permitted ambient temp. for motor (transport/storage)</b>	- 40 °C
<b>Installation position</b>	Shaft horizontal or rotor on top; rotor on bottom on request
<b>Condensation drainage holes</b>	None
<b>Mode</b>	S1
<b>Motor bearing</b>	Ball bearing
<b>Technical features</b>	<ul style="list-style-type: none"> <li>- Operation and alarm display: reversible voltage output 0 V / +15 V</li> <li>- Integrated PID controller</li> <li>- Motor current limitation</li> <li>- PFC, active</li> <li>- RS-485 ebmBUS</li> <li>- Soft start</li> <li>- Control interface with SELV potential safely disconnected from supply</li> <li>- Thermal overload protection for electronics/motor</li> <li>- Line undervoltage / phase failure detection</li> </ul>
<b>EMC immunity to interference</b>	According to EN 61000-6-2 (industrial environment)
<b>EMC circuit feedback</b>	According to EN 61000-3-2/3
<b>EMC interference emission</b>	According to EN 61000-6-4 (industrial environment)
<b>Touch current according to IEC 60990 (measuring circuit Fig. 4, TN system)</b>	<= 3.5 mA
<b>Electrical hookup</b>	With plug
<b>Motor protection</b>	Thermal overload protector (TOP) internally connected
<b>With cable</b>	Variable
<b>Protection class</b>	I (with customer connection of protective earth)
<b>Conformity with standards</b>	
<b>Approval</b>	CCC

## Product drawing

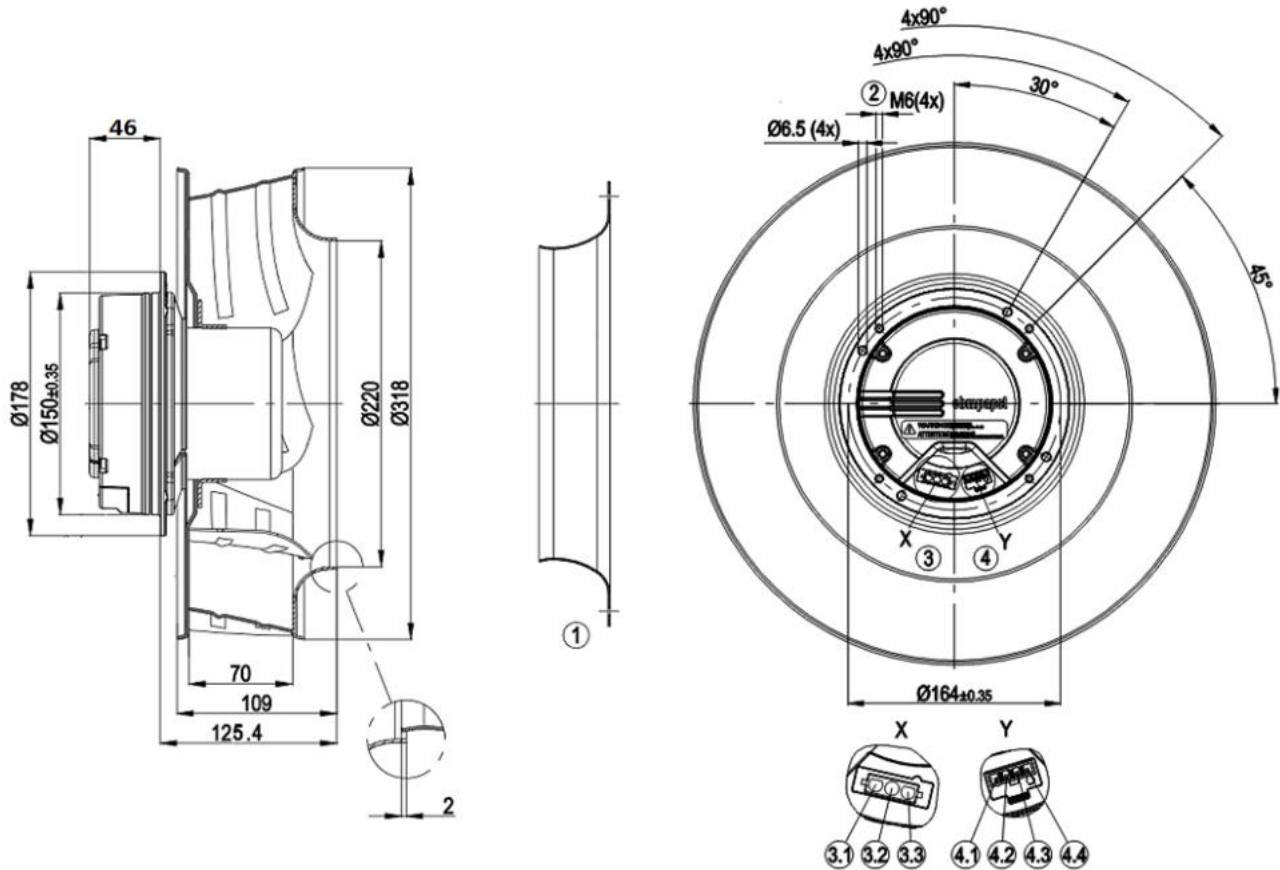

1	Accessory part: inlet ring 31050-2-4013 not included in scope of delivery
2	Max. clearance for screw 10 mm
3	Header Lonco no. C63502-3A, mating connectors with sockets not included in scope of delivery
3.1	PE
3.2	N
3.3	L
4	4-pole header Molex 39-30-2040, mating connector with sockets not included in scope of delivery
4.1	RSB
4.2	RSA
4.3	+15 V; in case of fault: 0 V
4.4	0 V; in case of fault: +15 V

# EC centrifugal fan

backward-curved, single-intake

## Connection diagram

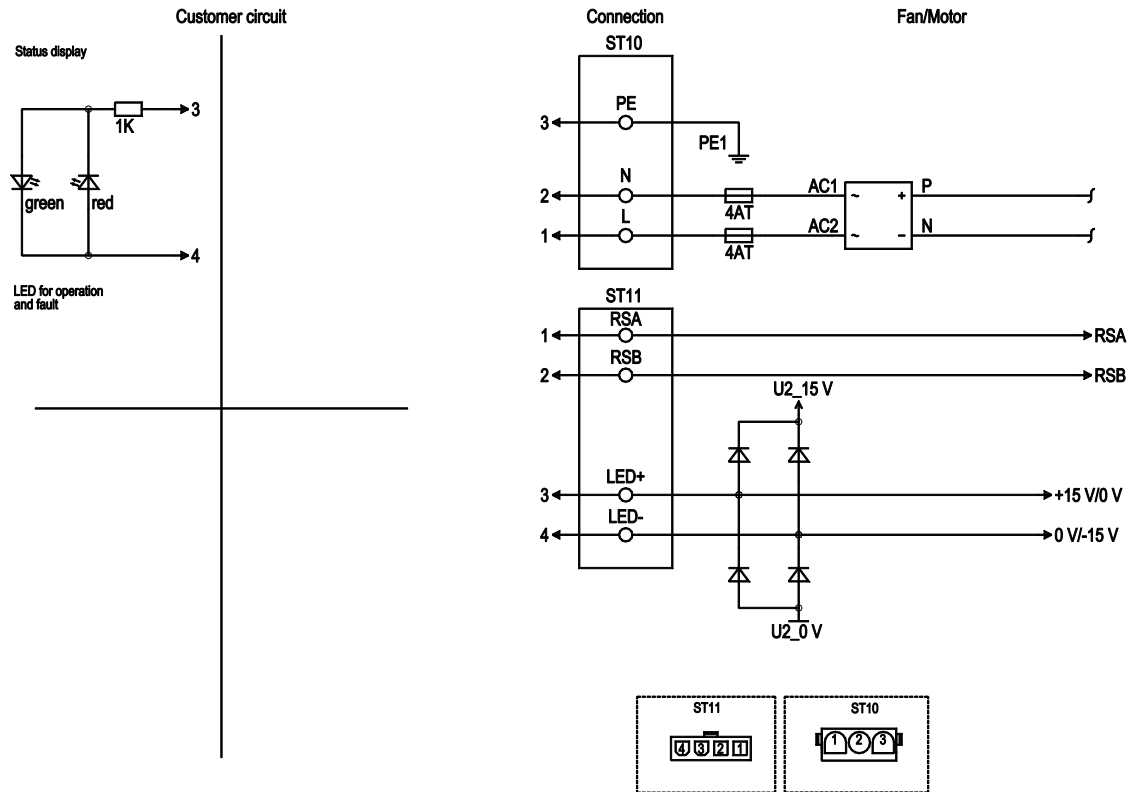

No.	Conn.	Designation	Color	Function/assignment
10	1	L		Power supply, phase, 50/60 Hz
10	2	N		Power supply, neutral conductor, 50/60 Hz
10	3	PE		Protective earth
11	1	RSA		RS485 interface for ebmBUS, RSA, SELV
11	2	RSB		RS485 interface for ebmBUS, RSB, SELV
11	3	LED +		Voltage output 15 V (+15%/-10%), max. 30 mA, power supply for external devices (e.g. status display for LED), SELV
11	4	LED -		Reference ground for control interface, SELV

## Curves: Air performance 50 Hz

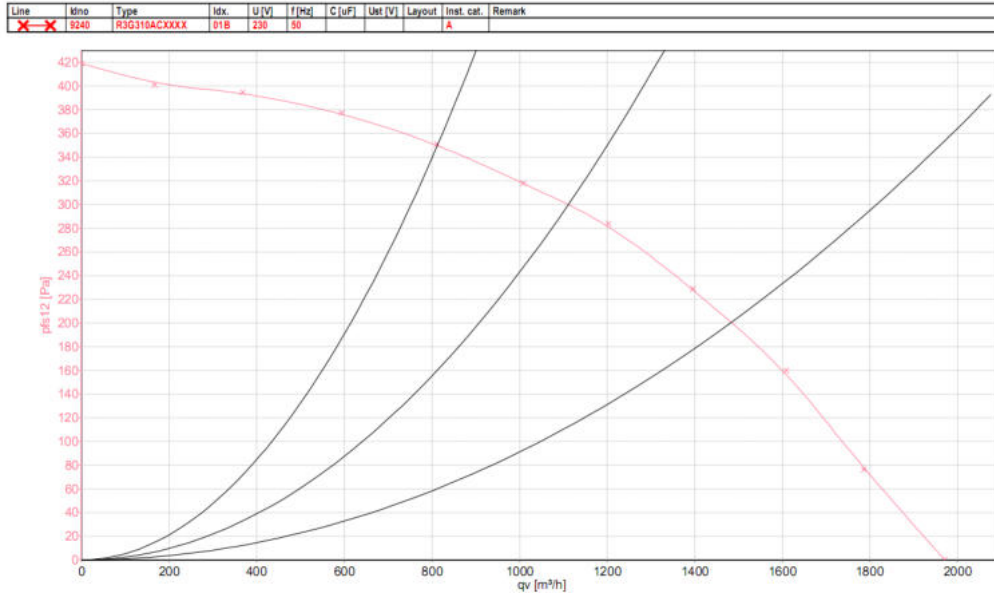

Measurement:9240

Air performance measured according to ISO 5801 installation category A. For detailed information on the measurement setup, contact ebm-papst. Intake sound level: Sound power level according to ISO 13347 / sound pressure level measured at 1 m distance from fan axis. The values given are valid under the specified measuring conditions and may vary due to conditions of installation. For deviations from the standard configuration, the parameters have to be checked on the installed unit.

## Measured values

	U	f	n	P	I	q <sub>v</sub>	p <sub>fs</sub>
	V	Hz	min <sup>-1</sup>	W	A	m <sup>3</sup> /h	Pa
1	230	50	1745	138	0.62	1971	0
2	230	50	1745	176	0.77	1484	200
3	230	50	1745	186	0.82	1112	300
4	230	50	1745	177	0.78	810	350

U = Power supply · f = Frequency · n = Speed (rpm) · P<sub>ed</sub> = Power consumption · I = Current draw · q<sub>v</sub> = Air flow · p<sub>fs</sub> = Pressure increase

