

EC centrifugal fan

backward-curved, single-intake

for rail applications

R3G280-RR15-S9 ebmpapst Datasheet

sales@fansco.com

www.fansco.com

Limited partnership · Headquarters Muldingen

Amtsgericht (court of registration) Stuttgart · HRA 590344

General partner Elektrobau Muldingen GmbH · Headquarters Muldingen

Amtsgericht (court of registration) Stuttgart · HRB 590142

Nominal data

| | | |
|--------------------------|-------------------|-----------|
| Type | R3G280-RR15-S9 | |
| Motor | M3G084-DF | |
| Nominal voltage | VDC | 110 |
| Nominal voltage range | VDC | 50 .. 138 |
| Method of obtaining data | | ml |
| Status | | prelim. |
| Speed (rpm) | min ⁻¹ | 2900 |
| Power consumption | W | 680 |
| Current draw | A | 6.2 |
| Min. ambient temperature | °C | -40 |
| Max. ambient temperature | °C | 60 |

ml = Max. load · me = Max. efficiency · fa = Free air · cs = Customer specification · ce = Customer equipment
Subject to change



Technical description

| | |
|--|---|
| Weight | 4.94 kg |
| Size | 280 mm |
| Motor size | 84 |
| Rotor surface | Painted black |
| Impeller material | PA plastic UL94 V0 |
| Housing material | Die-cast aluminum |
| Number of blades | 6 |
| Direction of rotation | Clockwise, viewed toward rotor |
| Degree of protection | IP55 |
| Insulation class | "F" |
| Moisture (F) / Environmental (H) protection class | H3 |
| Max. permitted ambient temp. for motor (transport/storage) | +80 °C |
| Min. permitted ambient temp. for motor (transport/storage) | -40 °C |
| Installation position | Shaft horizontal or rotor on bottom; rotor on top on request |
| Condensation drainage holes | On rotor side |
| Mode | S1 |
| Motor bearing | Ball bearing; (sealed) |
| Technical features | <ul style="list-style-type: none"> - Output 10 VDC, max. 10 mA - Operation and alarm display - Alarm relay - Motor current limitation - RS-485 MODBUS-RTU - Soft start - EEPROM write cycles: 100,000 maximum - Control input 0-10 VDC / PWM - Control interface with SELV potential safely disconnected from the mains - Overvoltage detection - Thermal overload protection for electronics/motor - Line undervoltage detection |
| EMC regulations | According to EN 50121-3-2 |
| Motor protection | Thermal overload protector (TOP) internally connected |
| With cable | Variable |
| Protection class assignment | <p>I; If a protective earth is connected by the customer</p> <p>This component for installation may have several local protection classes. This information relates to this component's basic design.</p> <p>The final protection class is based on the component's intended installation and connection.</p> |
| Conformity with standards | EN 15085-1, CPC3: 2013; EN 45545-2, HL3: 2013; EN 50155: 2008; EN 61373, Cat. 1B: 2010; EN 50121-3-2: 2006 |
| Comment on CE | Codesign Directive 2009/125/EC + Fan Regulation (EC) No. 327/2011 does not apply, as use only in means of transport for transporting persons or goods. |
| Approval | EAC |
| Comment | <p>If voltage (e.g. 230 VAC) is passed through the alarm relay, the SELV signal wires lose their property of reinforced insulation, meaning they then have only basic insulation</p> <p>The SELV property (reinforced insulation) is not lost when voltages of up to 110 VDC are passed through the alarm relay.</p> |

EC centrifugal fan

backward-curved, single-intake
for rail applications

Product drawing

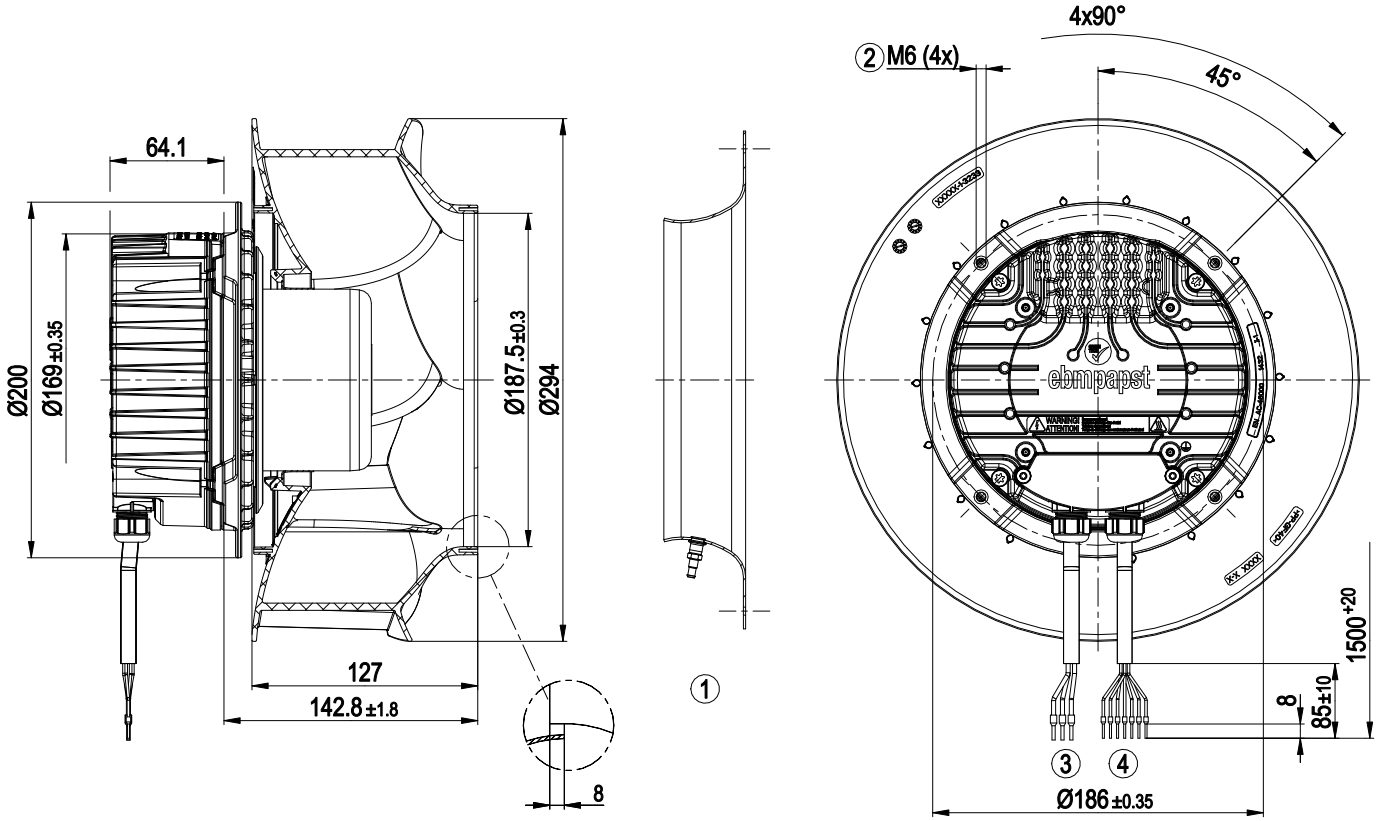

| | |
|---|---|
| 1 | Accessory part: Inlet ring 28004-2-4013 with pressure tap (k-factor: 77) not included in scope of delivery |
| 2 | Max. clearance for screw 16 mm |
| 3 | Cable, halogen-free, railway application EN 45545, 4G 1.5 mm ² 3x wire-end ferrule, 1x wire not routed externally |
| 4 | Cable, halogen-free, railway application EN 45545, 7x 0.5 mm ² 7x wire-end ferrule |



R3G280-RR15-S9

EC centrifugal fan

backward-curved, single-intake
for rail applications

Accessory part

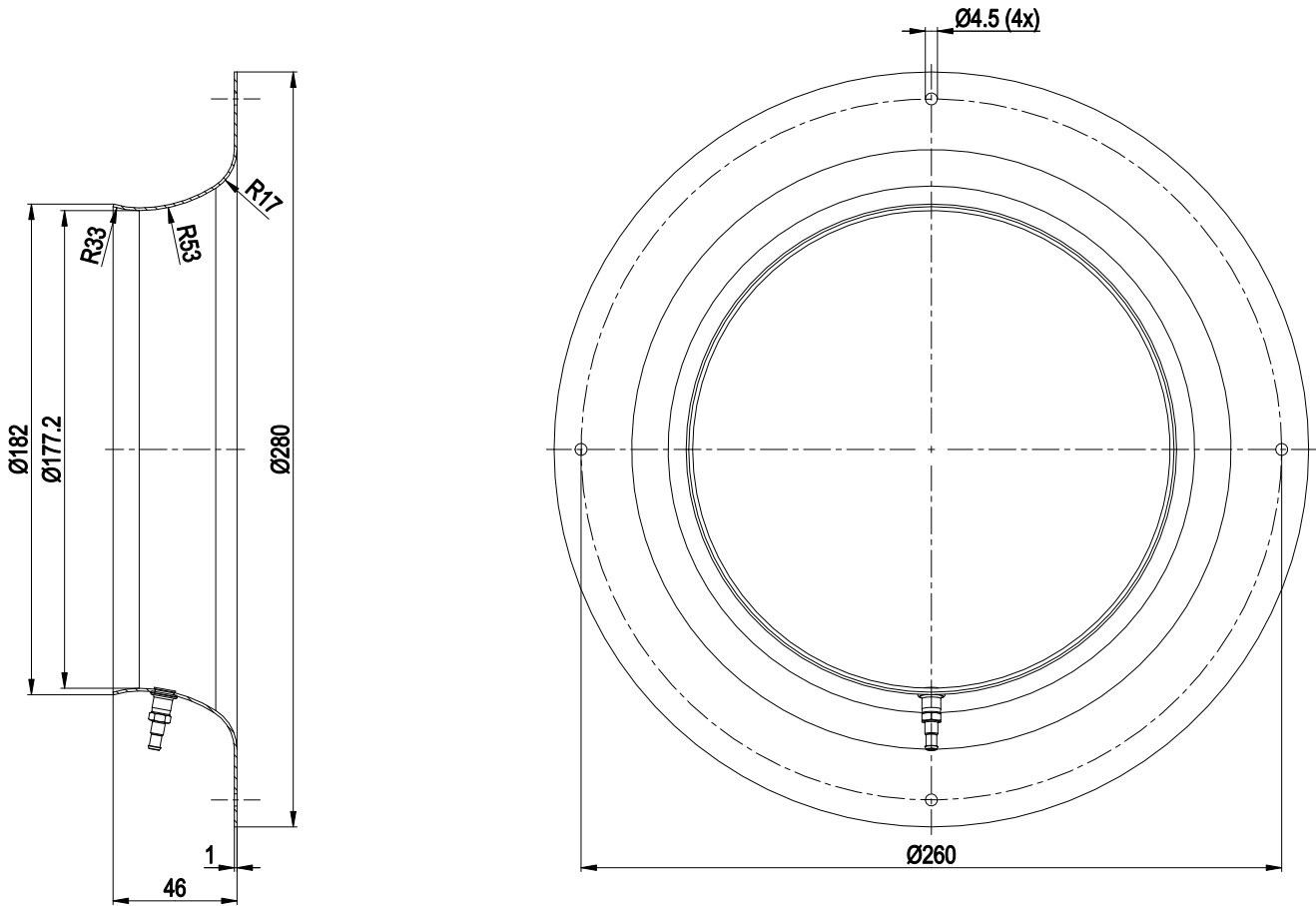

Inlet ring 28004-2-4013 with pressure tap (k-factor: 77)



EC centrifugal fan

backward-curved, single-intake
for rail applications

Connection diagram

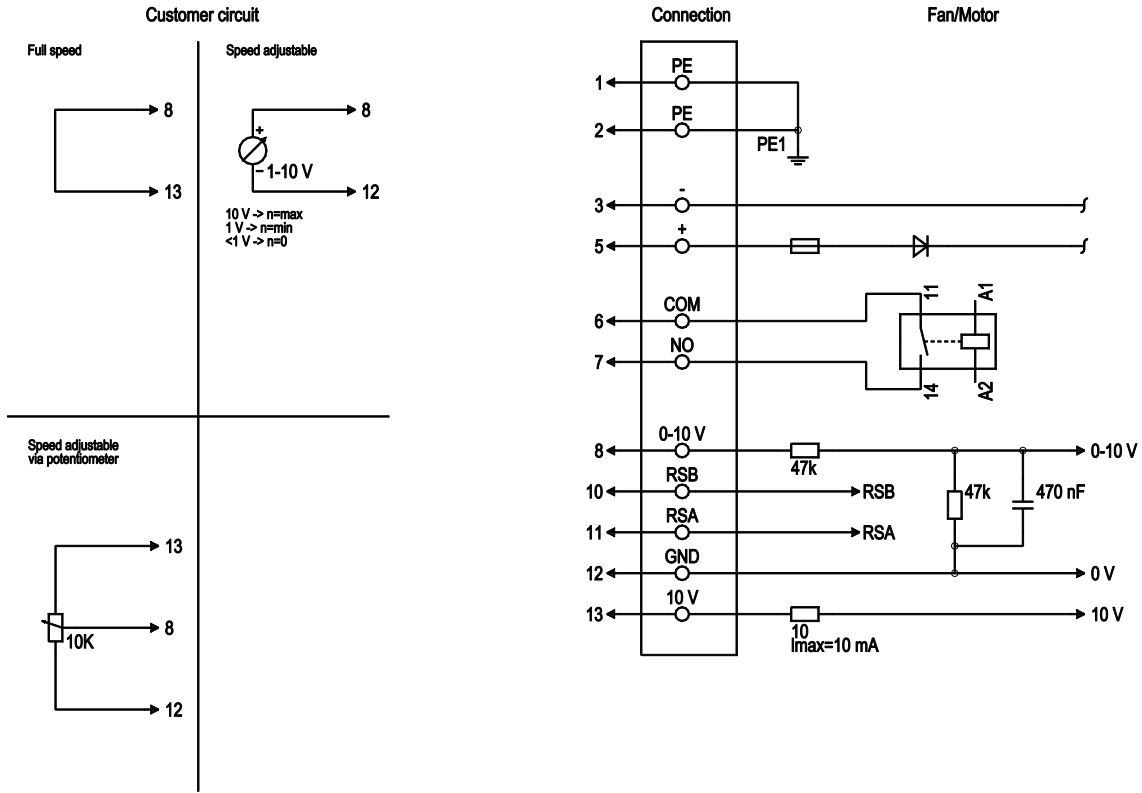

| No. | Conn. | Designation | Color | Function/assignment |
|-----|-------|-------------|--------------|---|
| 1 | 1 | PE | green/yellow | Protective earth |
| 1 | 2 | PE | - | not brought out via wire |
| 1 | 3 | - | black | Power supply, GND, voltage range see nameplate |
| 1 | 5 | + | brown | Power supply, see nameplate for voltage range |
| 2 | 6 | COM | gray | Status relay, floating status contact, common connection, contact rating 250 VAC/30 VDC max. 2 A (AC1), min. 1 mA/5 VDC, reinforced insulation on control interface side, basic insulation on supply side in accordance with EN 50124-1 |
| 2 | 7 | NO | orange | Status relay, floating status contact, normally open contact, contact rating 250 VAC/30 VDC max. 2 A (AC1), min. 1 mA/5 VDC, reinforced insulation on control interface side, basic insulation on supply side in accordance with EN 50124-1 |
| 2 | 8 | 0-10 V | yellow | Analog input (set value) SELV, 0-10 V, $R_i = 100\text{ k}\Omega$, adjustable curve |
| 2 | 10 | RSB | brown | RS-485 interface for MODBUS, RSB; SELV, bus termination resistor provided by customer |
| 2 | 11 | RSA | white | RS-485 interface for MODBUS, RSA; SELV, bus termination resistor provided by customer |
| 2 | 12 | GND | blue | Reference ground for control interface; SELV |
| 2 | 13 | +10 V | red | Fixed voltage output 10 VDC, SELV, +10 V +/-3%, max. 10 mA, short-circuit-proof, power supply for external devices (e.g. potentiometers) |



EC centrifugal fan

backward-curved, single-intake
for rail applications

Curves: Air performance

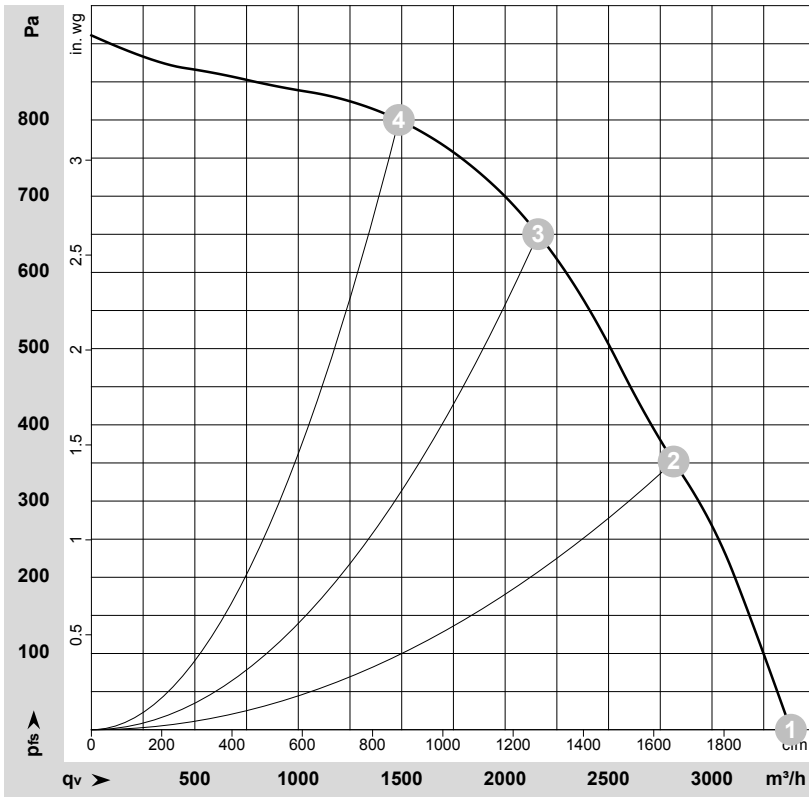

$\rho = 1.15 \text{ kg/m}^3 \pm 2 \%$

Measurement: LU-208139-1

Air performance measured according to ISO 5801 installation category A. For detailed information on the measurement setup, contact ebmpapst. Intake sound level: Sound power level according to ISO 13347 / sound pressure level measured at 1 m distance from fan axis. The values given are valid under the specified measuring conditions and may vary due to conditions of installation. For deviations from the standard configuration, the parameters have to be checked on the installed unit.

Measured values

| | U | n | P _{ed} | I | q _v | p _{fs} | q _v | p _{fs} |
|---|-----|-------------------|-----------------|------|-------------------|-----------------|----------------|-----------------|
| | V | min ⁻¹ | W | A | m ³ /h | Pa | cfm | in. wg |
| 1 | 110 | 2900 | 510 | 4.63 | 3380 | 0 | 1990 | 0.00 |
| 2 | 110 | 2900 | 624 | 5.67 | 2815 | 350 | 1655 | 1.41 |
| 3 | 110 | 2900 | 680 | 6.20 | 2160 | 650 | 1270 | 2.61 |
| 4 | 110 | 2900 | 637 | 5.78 | 1485 | 800 | 875 | 3.21 |

U = Voltage · n = Speed (rpm) · P_{ed} = Power consumption · I = Current draw · q_v = Air flow · p_{fs} = Pressure increase

