

EC centrifugal fan - RadiCal

backward-curved, single-intake

for rail applications

R3G280-RR05-N2 ebmpapst Datasheet

sales@fansco.com

www.fansco.com

Limited partnership · Headquarters Muldingen

Amtsgericht (court of registration) Stuttgart · HRA 590344

General partner Elektrobau Muldingen GmbH · Headquarters Muldingen

Amtsgericht (court of registration) Stuttgart · HRB 590142

Nominal data

Type	R3G280-RR05-N2	
Motor	M3G084-DF	
Phase		3~
Nominal voltage	VAC	400
Nominal voltage range	VAC	380 .. 480
Frequency	Hz	50/60
Method of obtaining data		ml
Speed (rpm)	min ⁻¹	2900
Power consumption	W	640
Current draw	A	1.05
Min. ambient temperature	°C	-40
Max. ambient temperature	°C	70

ml = Max. load · me = Max. efficiency · fa = Free air · cs = Customer specification · ce = Customer equipment
Subject to change



Technical description

Weight	5.44 kg
Size	280 mm
Motor size	84
Rotor surface	Painted black
Impeller material	PA plastic UL94 V0
Housing material	Die-cast aluminum
Number of blades	6
Direction of rotation	Clockwise, viewed toward rotor
Degree of protection	IP55
Insulation class	"F"
Moisture (F) / Environmental (H) protection class	H3
Max. permitted ambient temp. for motor (transport/storage)	+80 °C
Min. permitted ambient temp. for motor (transport/storage)	-40 °C
Installation position	Shaft horizontal or rotor on bottom; rotor on top on request
Condensation drainage holes	On rotor side
Mode	S1
Motor bearing	Hybrid bearing; (sealed)
Technical features	<ul style="list-style-type: none"> - Output 10 VDC, max. 10 mA - Alarm relay - Integrated PID controller - Run monitoring - Power limiter - Motor current limitation - Emergency operation - PFC, passive - RS-485 MODBUS-RTU - Soft start - EEPROM write cycles: 100,000 maximum - Control input 0-10 VDC / PWM - Control interface with SELV potential safely disconnected from the mains - Overvoltage detection - Thermal overload protection for electronics/motor - Line undervoltage / phase failure detection
EMC regulations	According to EN 50121-3-2
Touch current according to IEC 60990 (measuring circuit Fig. 4, TN system)	<= 3.5 mA
Motor protection	Thermal overload protector (TOP) internally connected
With cable	Lateral
Protection class	I (if protective earth is connected by customer to the housing's connection point)
Conformity with standards	EN 15085-1+A1:2013, CPC3; EN 45545-2:2020, HL3; EN 50155:2018; E N 61373:2010, Cat.1B
Approval	EAC

EC centrifugal fan - RadiCal

backward-curved, single-intake

for rail applications

Comment

A prerequisite for operation is a Class 1 vehicle electrical system architecture according to EN 50533; if supply potential (e.g. 230 VAC) is passed through the alarm relay, the SELV signal wires lose their property of reinforced insulation and they then have only basic insulation

The SELV property (reinforced insulation) is not lost when voltages of up to 110 VDC are passed through the alarm relay.



EC centrifugal fan - RadiCal

backward-curved, single-intake
for rail applications

Product drawing

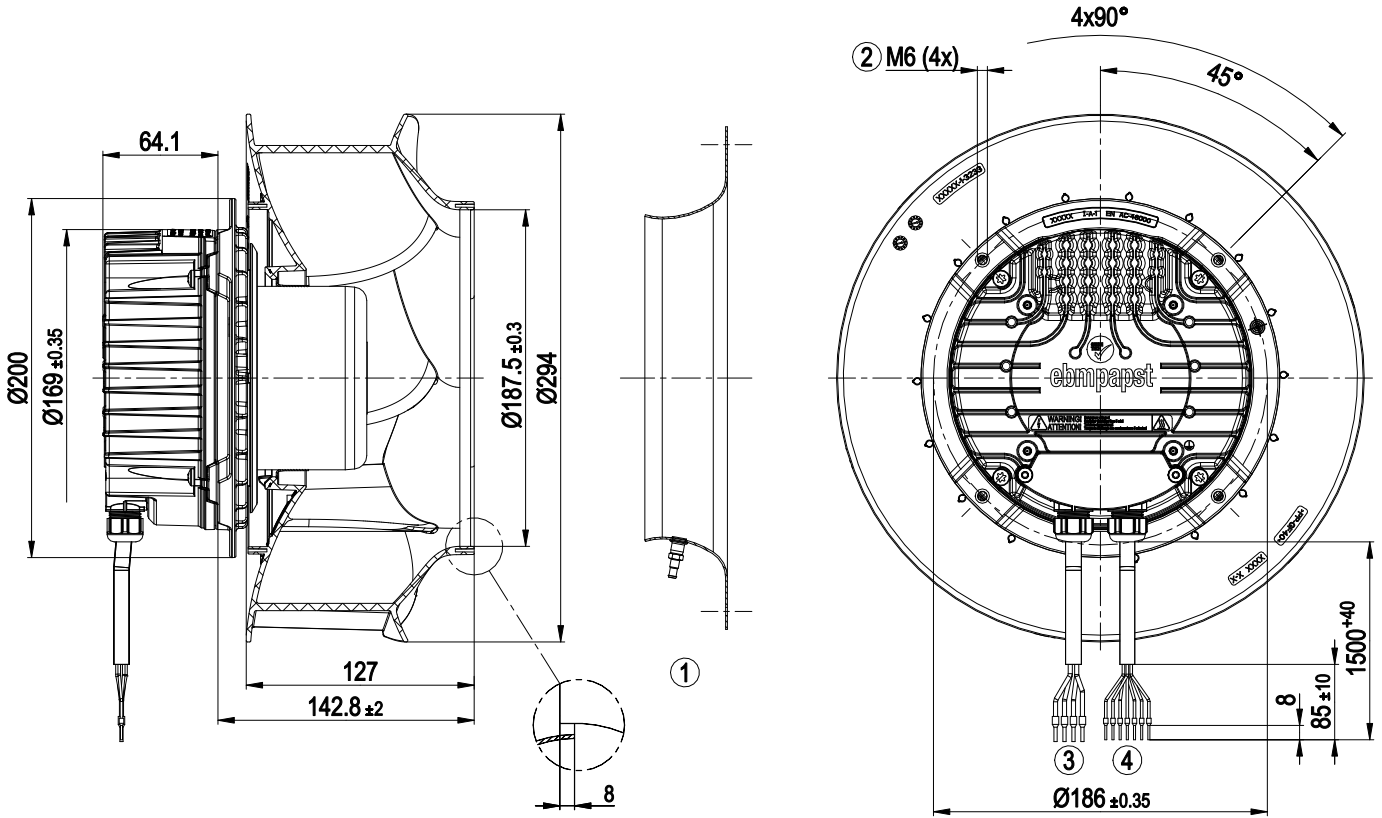

1	Accessory part: Inlet ring 28004-2-4013 with pressure tap (k-factor: 77) not included in scope of delivery
2	Max. clearance for screw 16 mm
3	Cable, halogen-free, railway application EN 45545, 4G 1.5 mm ² 4x wire-end ferrule
4	Cable, halogen-free, railway application EN 45545, 7x 0.5 mm ² 7x wire-end ferrule



EC centrifugal fan - RadiCal

backward-curved, single-intake

for rail applications

Accessory part

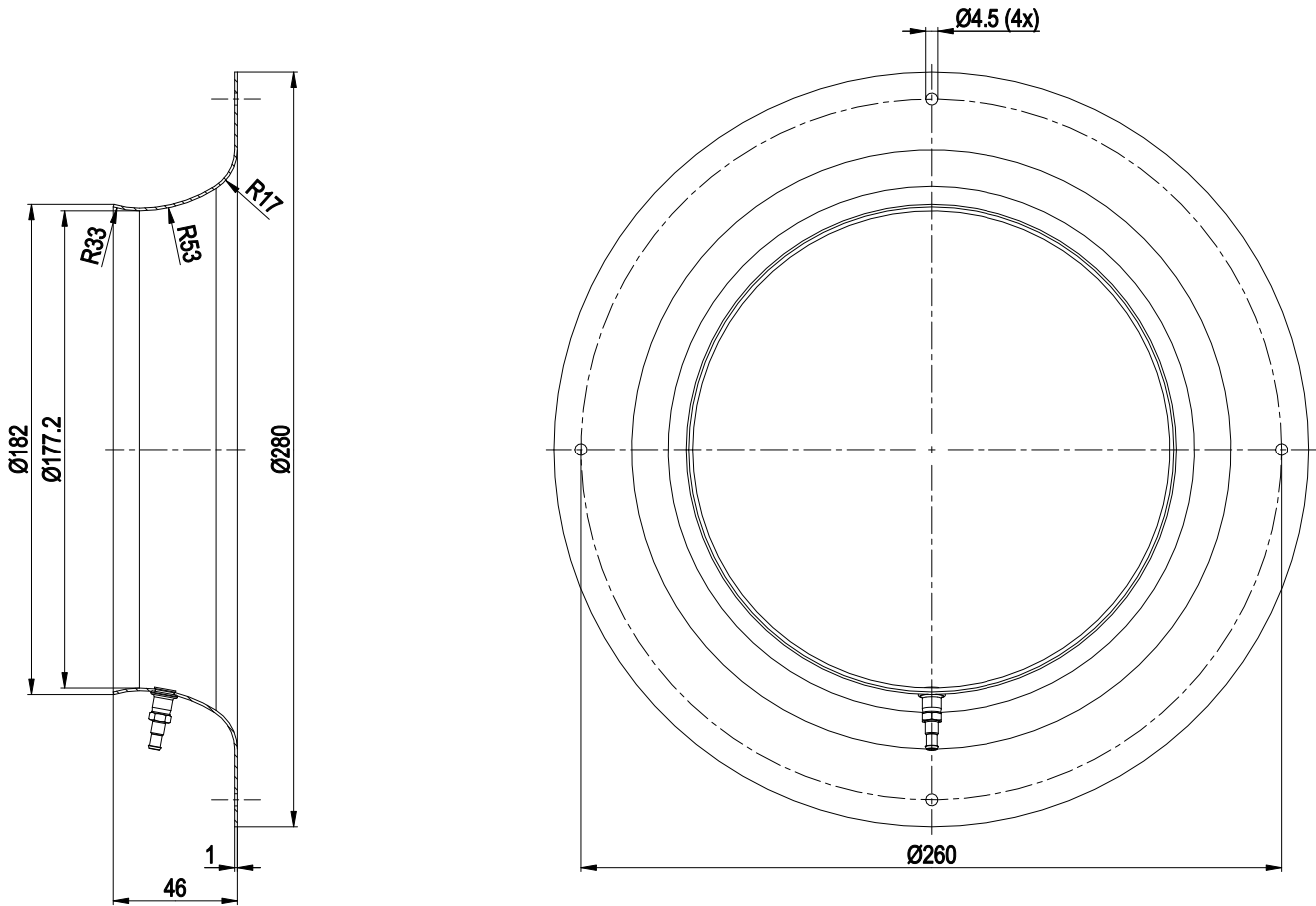

Inlet ring 28004-2-4013 with pressure tap (k-factor: 77)



EC centrifugal fan - RadiCal

backward-curved, single-intake
for rail applications

Connection diagram

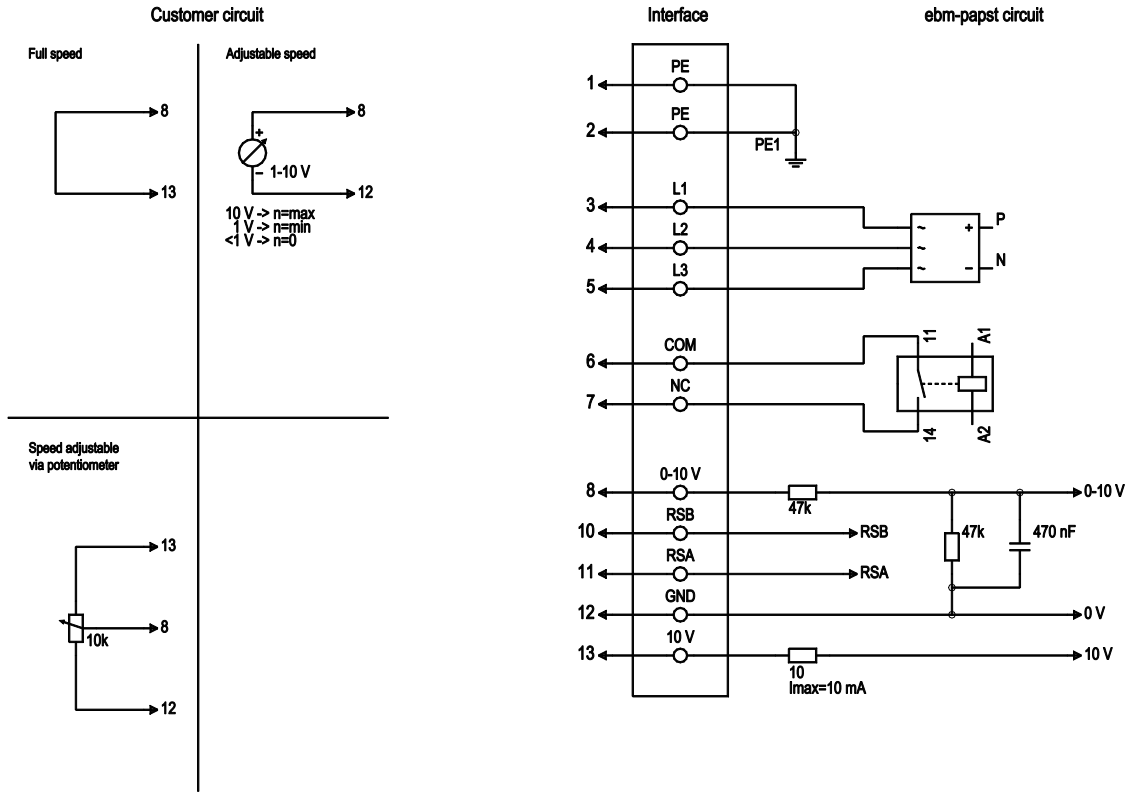

No.	Conn.	Designation	Color	Function/assignment
1	1	PE	green/yellow	Protective earth
1	2	PE	-	not brought out via wire
1	3	L1	black	Power supply, phase 50/60 Hz
1	4	L2	blue	Power supply, phase 50/60 Hz
1	5	L3	brown	Power supply, phase 50/60 Hz
2	6	COM	gray	Status relay, floating status contact, common connection, contact rating 250 VAC / max. 2 A (AC1), min. 1 mA / 5 VDC, reinforced insulation on control interface side, basic insulation on supply side according to EN 50124-1
2	7	NC	orange	Status relay, floating status contact, break for failure, contact rating 250 VAC / max. 2 A (AC1), min. 1 mA / 5 VDC, reinforced insulation on control interface side, basic insulation on supply side according to EN 50124-1
2	8	0-10V	yellow	Analog input (set value) SELV, 0-10 V, Ri = 100 kΩ, adjustable curve
2	10	RSB	brown	RS485 interface for MODBUS, RSB; SELV
2	11	RSA	white	RS485 interface for MODBUS, RSA; SELV
2	12	GND	blue	Reference ground for control interface, SELV
2	13	+10V	red	Fixed voltage output 10 VDC, +10 V ± 3%, max. 10 mA, short-circuit-proof, power supply for external devices (e.g. pot); SELV



Curves: Air performance 50 Hz

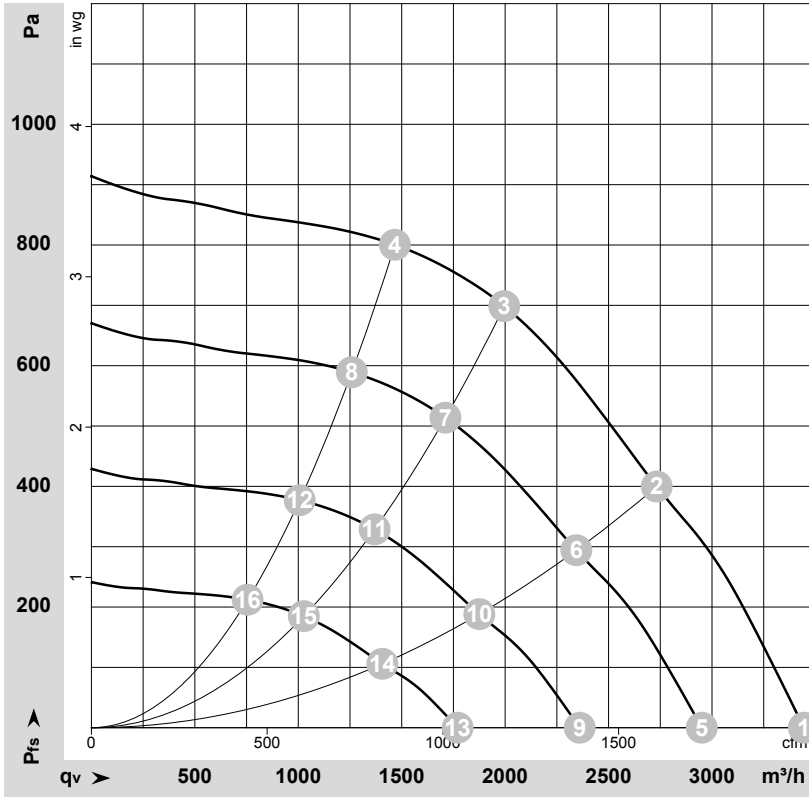

$\rho = 1.15 \text{ kg/m}^3 \pm 2 \%$

Measurement: LU-177026-1

Air performance measured according to ISO 5801 installation category A. For detailed information on the measurement setup, contact ebmpapst. Intake sound level: Sound power level according to ISO 13347 / sound pressure level measured at 1 m distance from fan axis. The values given are valid under the specified measuring conditions and may vary due to conditions of installation. For deviations from the standard configuration, the parameters have to be checked on the installed unit.

Measured values

	U	f	n	P _{ed}	I	LpA _{in}	LwA _{in}	q _v	P _{fs}	q _v	P _{fs}
	V	Hz	min ⁻¹	W	A	dB(A)	dB(A)	m ³ /h	Pa	cfm	in. wg
1	400	50	2900	473	0.81	79	86	3445	0	2025	0.00
2	400	50	2900	599	1.01	73	80	2735	400	1610	1.61
3	400	50	2900	640	1.05	68	76	1995	700	1175	2.81
4	400	50	2900	587	0.97	69	77	1465	800	865	3.21
5	400	50	2500	298	0.51	75	82	2950	0	1735	0.00
6	400	50	2500	378	0.64	69	76	2345	293	1380	1.18
7	400	50	2500	406	0.66	64	72	1710	516	1005	2.07
8	400	50	2500	370	0.61	66	73	1260	590	740	2.37
9	400	50	2000	152	0.26	69	77	2360	0	1390	0.00
10	400	50	2000	194	0.33	63	71	1875	187	1105	0.75
11	400	50	2000	208	0.34	59	66	1370	330	805	1.32
12	400	50	2000	190	0.31	60	67	1005	378	595	1.52
13	400	50	1500	64	0.11	62	69	1770	0	1040	0.00
14	400	50	1500	82	0.14	56	63	1405	105	830	0.42
15	400	50	1500	88	0.14	52	59	1025	186	605	0.75
16	400	50	1500	80	0.13	53	60	755	212	445	0.85

U = Voltage · f = Frequency · n = Speed (rpm) · P_{ed} = Power consumption · I = Current draw · LpA_{in} = Sound pressure level intake side · LwA_{in} = Sound power level intake side
 q_v = Air flow · p_{fs} = Pressure increase

