

R3G280-RO40-71 ebmpapst Datasheet

sales@fansco.com

www.fansco.com

Limited partnership · Headquarters Mulfingen

Amtsgericht (court of registration) Stuttgart · HRA 590344

General partner Elektrobau Mulfingen GmbH · Headquarters Mulfingen

Amtsgericht (court of registration) Stuttgart · HRB 590142



Nominal data

Type	R3G280-RO40-71	
Motor	M3G084-DF	
Phase		1~
Nominal voltage	VAC	230
Nominal voltage range	VAC	200 .. 277
Frequency	Hz	50/60
Method of obtaining data		ml
Speed (rpm)	min ⁻¹	2530
Power consumption	W	470
Current draw	A	3.1
Min. ambient temperature	°C	-25
Max. ambient temperature	°C	40

ml = Max. load · me = Max. efficiency · fa = Free air · cs = Customer specification · ce = Customer equipment
Subject to change

Data according to ErP Directive

		Actual	Req. 2015			
01 Overall efficiency η_{es}	%	65.3	47.9	09 Power consumption P_{ed}	kW	0.45
02 Measurement category		A		09 Air flow q_v	m ³ /h	1805
03 Efficiency category		Static		09 Pressure increase p_{fs}	Pa	533
04 Efficiency grade N		79.4	62	10 Speed (rpm) n	min ⁻¹	2540
05 Variable speed drive		Yes		11 Specific ratio*		1.01

Data obtained at optimum efficiency level.

The ErP data is determined using a motor-impeller combination in a standardized measurement setup.

* Specific ratio = $1 + p_{fs} / 100\,000\text{ Pa}$

LU-137431



Technical description

Weight	4.1 kg
Fan size	280 mm
Rotor surface	Painted black
Electronics housing material	Die-cast aluminum
Impeller material	PP plastic
Number of blades	6
Direction of rotation	Clockwise, viewed toward rotor
Degree of protection	IP54
Insulation class	"B"
Moisture (F) / Environmental (H) protection class	F3-1
Max. permitted ambient temp. for motor (transport/storage)	+ 80 °C
Min. permitted ambient temp. for motor (transport/storage)	- 40 °C
Installation position	Shaft horizontal or rotor on top; rotor on bottom on request
Condensation drainage holes	None
Mode	S1
Motor bearing	Ball bearing
Technical features	<ul style="list-style-type: none"> - Output 10 VDC, max. 1.1 mA - Alarm relay - Motor current limitation - Soft start - Control input 0-10 VDC / PWM - Control interface with SELV potential safely disconnected from supply - Thermal overload protection for electronics/motor - Line undervoltage detection
EMC immunity to interference	According to EN 61000-6-2 (industrial environment)
EMC interference emission	According to EN 61000-6-3 (household environment)
Touch current according to IEC 60990 (measuring circuit Fig. 4, TN system)	<= 3.5 mA
Motor protection	Thermal overload protector (TOP) internally connected
With cable	Variable
Protection class	I (with customer connection of protective earth)
Conformity with standards	EN 61800-5-1; CE
Approval	UL 2111; CCC; EAC; CSA C22.2 No. 77

Product drawing

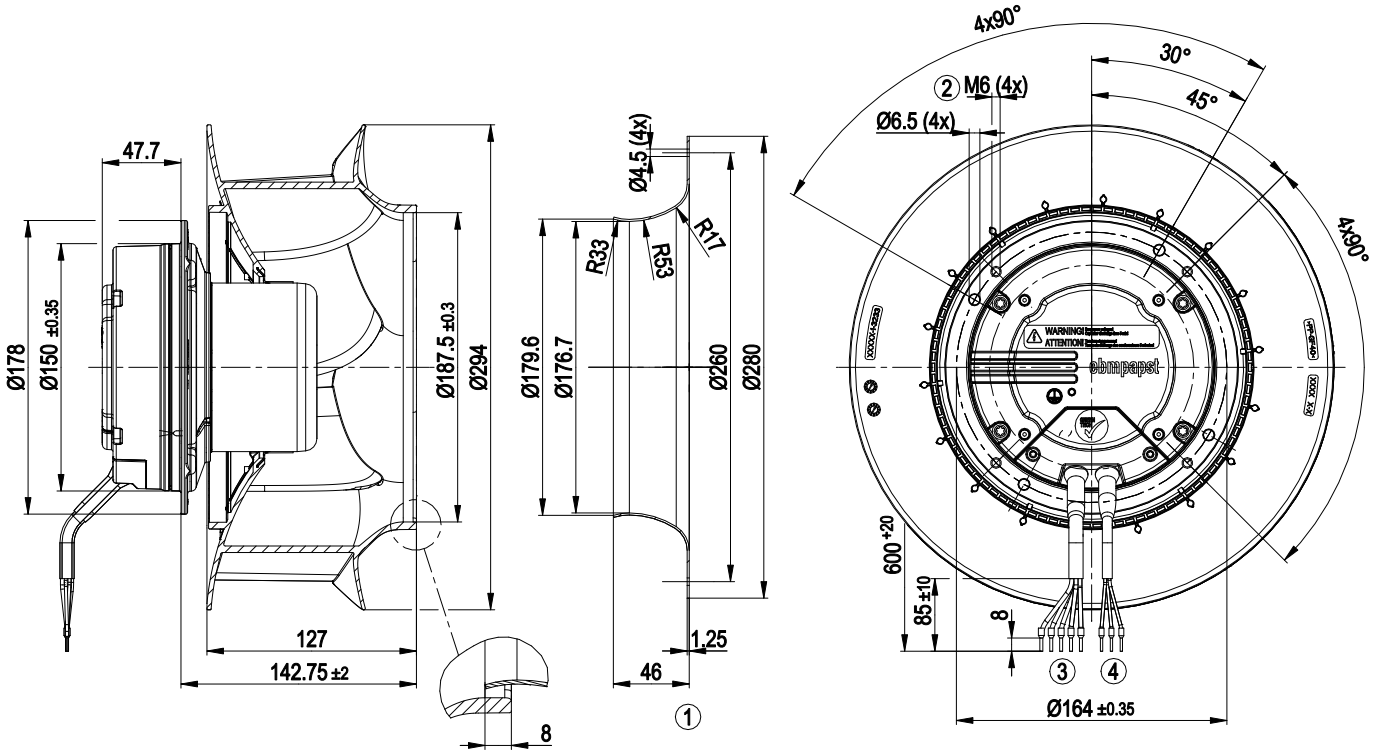

1	Accessory part: inlet ring 28000-2-4013 not included in scope of delivery
2	Max. clearance for screw 10 mm
3	Cable PVC AWG18, 5x crimped ferrules
4	Cable PVC AWG22, 3x crimped ferrules

Connection diagram

Customer circuit

Application notes for various control options

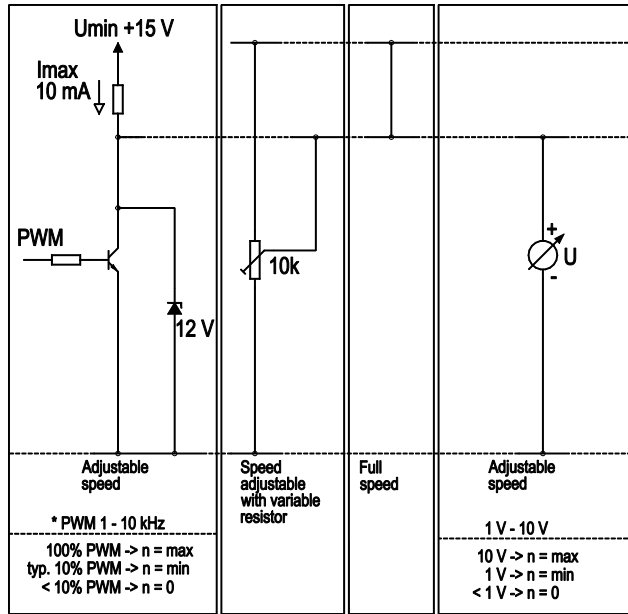

Connection

Fan / Motor

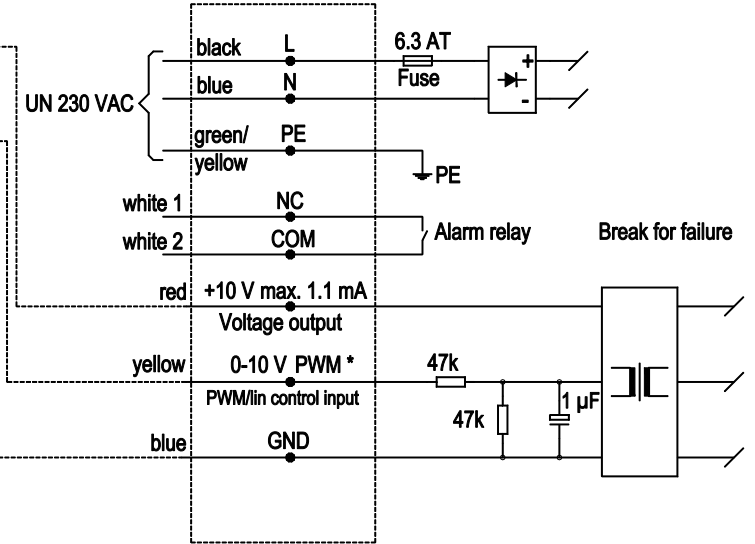

Curves: Air performance 50 Hz

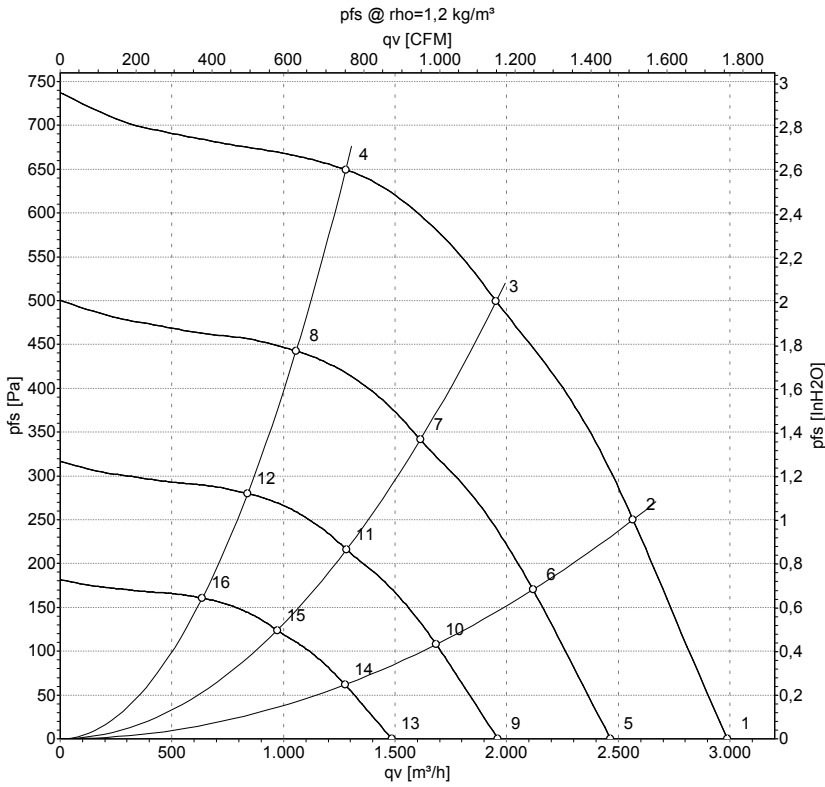

Measurement: LU-137431-1

Air performance measured according to ISO 5801 installation category A. For detailed information on the measurement setup, contact ebmpapst. Intake sound level: Sound power level according to ISO 13347 / sound pressure level measured at 1 m distance from fan axis. The values given are valid under the specified measuring conditions and may vary due to conditions of installation. For deviations from the standard configuration, the parameters have to be checked on the installed unit.

Measured values

	U	f	n	P _{ed}	I	LpA _{in}	LwA _{in}	qv	p _{fs}	qv	p _{fs}
	V	Hz	min ⁻¹	W	A	dB(A)	dB(A)	m³/h	Pa	CFM	inH2O
1	230	50	2530	335	2.20	73	80	2985	0	1760	0.00
2	230	50	2530	419	2.76	69	77	2565	250	1510	1.00
3	230	50	2530	470	3.10	65	73	1950	500	1150	2.01
4	230	50	2530	415	2.76	66	76	1280	650	755	2.61
5	230	50	2100	188	1.23			2465	0	1450	0.00
6	230	50	2100	236	1.55			2120	171	1245	0.69
7	230	50	2100	255	1.68			1615	341	950	1.37
8	230	50	2100	234	1.55			1055	443	620	1.78
9	230	50	1670	95	0.62			1960	0	1155	0.00
10	230	50	1670	119	0.78			1685	108	990	0.43
11	230	50	1670	128	0.84			1285	216	755	0.87
12	230	50	1670	117	0.78			840	280	495	1.12
13	230	50	1265	41	0.27			1485	0	875	0.00
14	230	50	1265	52	0.34			1275	62	750	0.25
15	230	50	1265	56	0.37			970	124	570	0.50
16	230	50	1265	51	0.34			635	161	375	0.65

U = Power supply · f = Frequency · n = Speed (rpm) · P_{ed} = Power consumption · I = Current draw · LpA_{in} = Sound pressure level intake side · LwA_{in} = Sound power level intake side
 qv = Air flow · p_{fs} = Pressure increase

