

R3G280-RB02-12 ebmpapst Datasheet

sales@fansco.com

www.fansco.com

Limited partnership · Headquarters Mulfingen

Amtsgericht (court of registration) Stuttgart · HRA 590344

General partner Elektrobau Mulfingen GmbH · Headquarters Mulfingen

Amtsgericht (court of registration) Stuttgart · HRB 590142

Nominal data

Type	R3G280-RB02-12	
Motor	M3G074-CF	
Phase		1~
Nominal voltage	VAC	230
Nominal voltage range	VAC	200 .. 240
Frequency	Hz	50/60
Method of obtaining data		ml
Speed (rpm)	min ⁻¹	1910
Power consumption	W	168
Current draw	A	1.4
Min. ambient temperature	°C	-25
Max. ambient temperature	°C	60

ml = Max. load · me = Max. efficiency · fa = Free air · cs = Customer specification · ce = Customer equipment
Subject to change

Data according to Commission Regulation (EU) 327/2011

		Actual	Req. 2015			
01 Overall efficiency η_{es}	%	64.4	43.1	09 Power consumption P_{ed}	kW	0.16
02 Measurement category		A		09 Air flow q_v	m ³ /h	1400
03 Efficiency category		Static		09 Pressure increase p_{fs}	Pa	240
04 Efficiency grade N		83.3	62	10 Speed (rpm) n	min ⁻¹	1775
05 Variable speed drive		Yes		11 Specific ratio [*]		1.00

Data obtained at optimum efficiency level.

The ErP data is determined using a motor-impeller combination in a standardized measurement setup.

^{*} Specific ratio = $1 + p_{fs} / 100\,000\text{ Pa}$

LU-138462



Technical description

Weight	2.7 kg
Fan size	280 mm
Rotor surface	Thick-film passivated
Impeller material	PP plastic
Number of blades	6
Direction of rotation	Clockwise, viewed toward rotor
Degree of protection	IP54
Insulation class	"B"
Moisture (F) / Environmental (H) protection class	F3-1
Max. permitted ambient temp. for motor (transport/storage)	+ 80 °C
Min. permitted ambient temp. for motor (transport/storage)	- 40 °C
Installation position	Any
Condensation drainage holes	None, open rotor
Cooling hole/opening	On rotor side
Mode	S1
Motor bearing	Ball bearing
Technical features	<ul style="list-style-type: none"> - Output 10 VDC, max. 10 mA - Tach output - Power limiter - Motor current limitation - Soft start - Control input 0-10 VDC / PWM - Control interface with SELV potential safely disconnected from the mains - Overvoltage detection - Thermal overload protection for electronics/motor - Line undervoltage detection
Touch current according to IEC 60990 (measuring circuit Fig. 4, TN system)	<= 3.5 mA
Motor protection	PTC thermistor
With cable	Variable
Protection class	I (with customer connection of protective earth)
Conformity with standards	EN 60335-1; CE
Approval	VDE

Product drawing

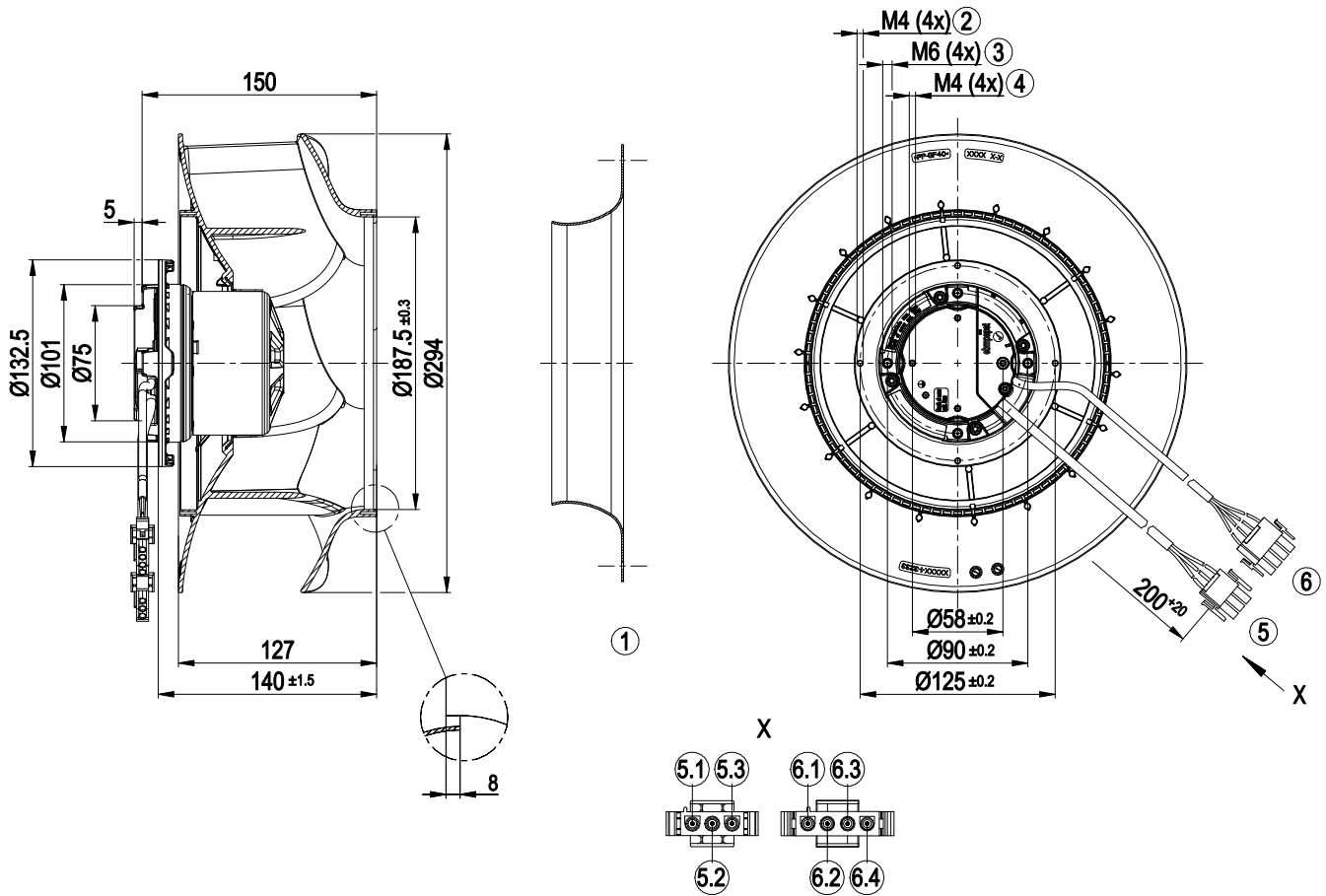

1	Accessory part: Inlet ring 28000-2-4013 not included in scope of delivery, other inlet rings on request
2	Max. clearance for screw 10 mm
3	Max. clearance for screw 10 mm
4	Max. clearance for screw 5 mm
5	Cable PVC AWG20, 3-pole connector housing tyco 350766-4, 3x plug pin tyco 350218-1
5.1	black
5.2	blue
5.3	green/yellow
6	Cable PVC AWG22, 4-pole connector housing tyco 350779-4, 4x plug pin tyco 926885-1
6.1	red
6.2	blue
6.3	yellow
6.4	white



Accessory part

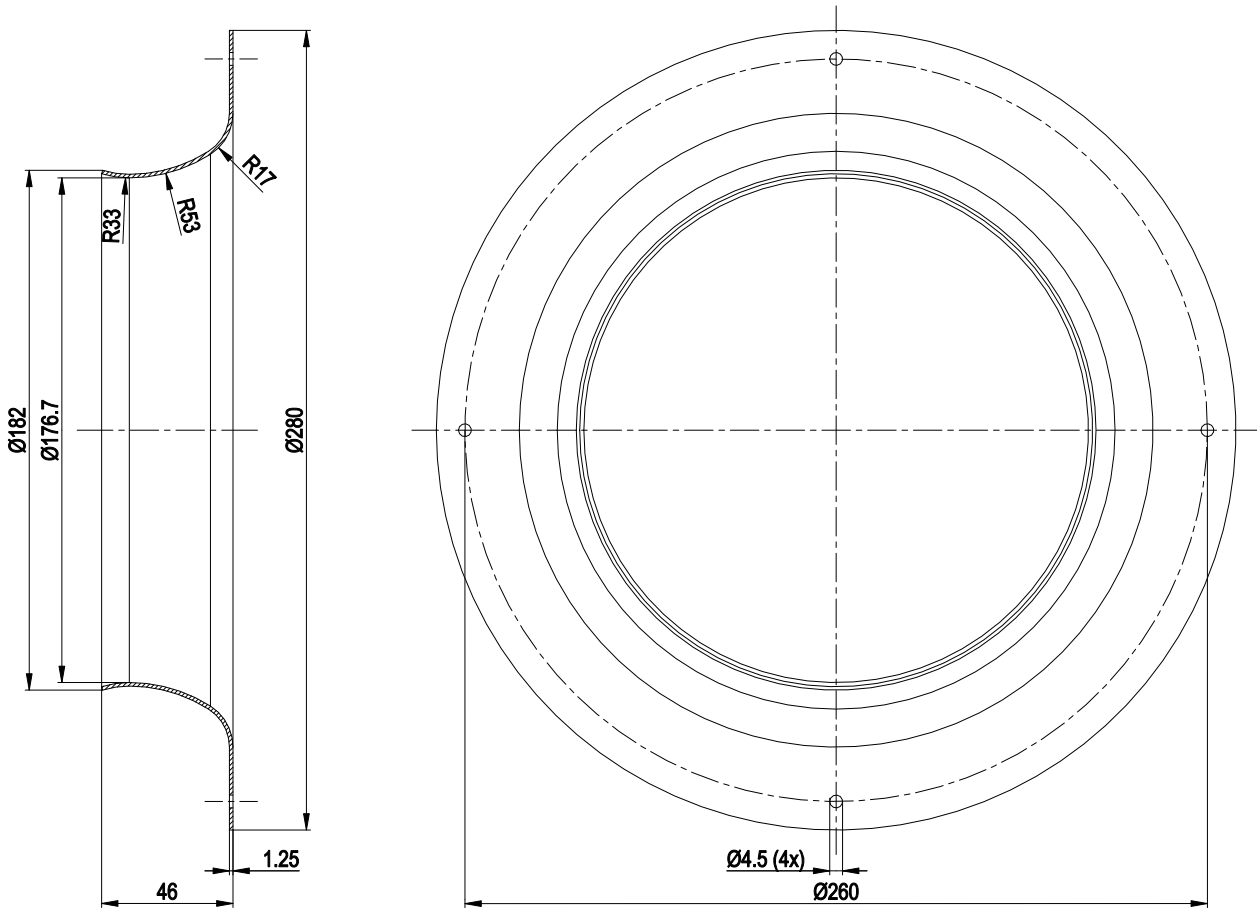

Accessory part: inlet ring 28000-2-4013 not included in scope of delivery



Connection diagram

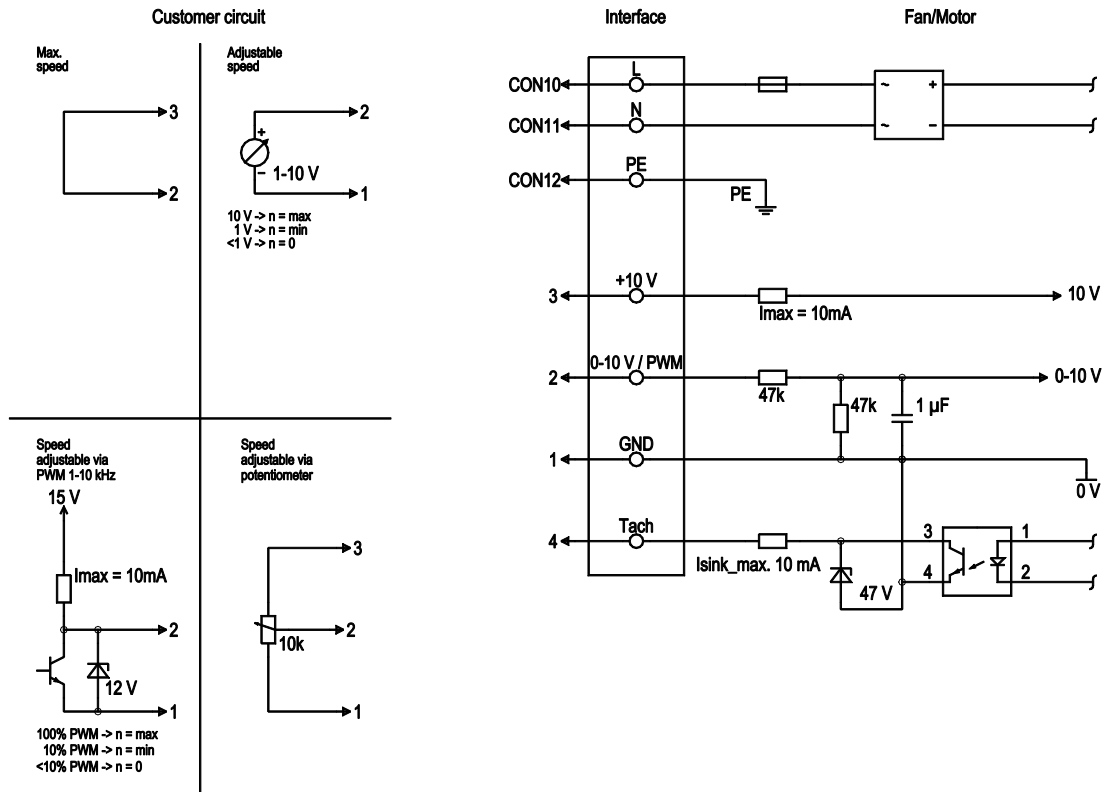

No.	Conn.	Designation	Color	Function/assignment
	CON10	L	black	Supply connection, power supply, phase, see nameplate for voltage range
	CON11	N	blue	Supply connection, power supply, neutral conductor, see nameplate for voltage range
	CON12	PE	green/yellow	Ground connection
	2	0- 10V PWM	yellow	0-10 V / PWM control input, R _i =100 kΩ, SELV
	4	Tach	white	Tach output, open collector, 1 pulse per revolution, I _{sink max} = 10 mA, SELV
	3	+10 V	red	Fixed voltage output 10 VDC +/-3 %, I _{max} . 10 mA, short-circuit-proof, power supply for ext. devices (e.g. pot), SELV
	1	GND	blue	Reference ground for control interface, SELV



Curves: Air performance 50 Hz

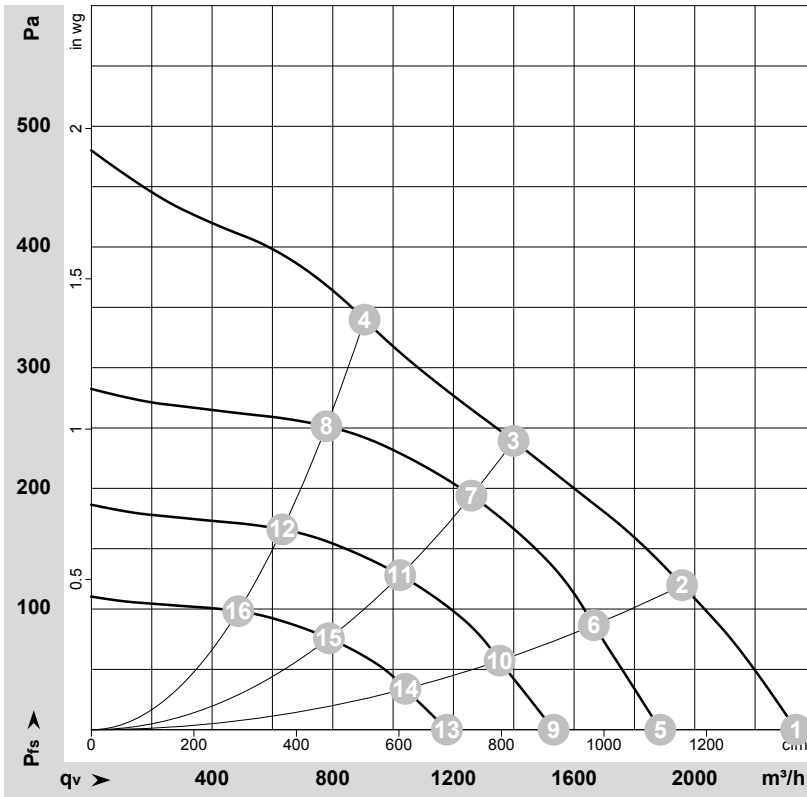

$\rho = 1.15 \text{ kg/m}^3 \pm 2 \%$

Measurement: LU-138462-1

Air performance measured according to ISO 5801 installation category A. For detailed information on the measurement setup, contact ebmpapst. Intake sound level: Sound power level according to ISO 13347 / sound pressure level measured at 1 m distance from fan axis. The values given are valid under the specified measuring conditions and may vary due to conditions of installation. For deviations from the standard configuration, the parameters have to be checked on the installed unit.

Measured values

	U	f	n	P _{ed}	I	LpA _{in}	LwA _{in}	q _v	p _{fs}	q _v	p _{fs}
	V	Hz	min ⁻¹	W	A	dB(A)	dB(A)	m ³ /h	Pa	cfm	inH ₂ O
1	230	50	1980	152	1.05	67	75	2335	0	1375	0.00
2	230	50	1910	168	1.40	62	69	1960	120	1150	0.48
3	230	50	1775	165	1.30	56	63	1400	240	825	0.96
4	230	50	1860	166	1.30	57	64	905	340	535	1.36
5	230	50	1600	80	0.55	62	69	1885	0	1110	0.00
6	230	50	1600	101	0.71	58	65	1665	87	980	0.35
7	230	50	1600	121	0.94	54	61	1260	195	740	0.78
8	230	50	1600	106	0.83	53	61	780	251	460	1.01
9	230	50	1300	43	0.30	57	64	1530	0	900	0.00
10	230	50	1300	54	0.38	53	60	1355	57	795	0.23
11	230	50	1300	65	0.50	48	56	1025	129	605	0.52
12	230	50	1300	57	0.44	48	55	635	166	375	0.67
13	230	50	1000	19	0.13	50	58	1180	0	695	0.00
14	230	50	1000	25	0.17	46	53	1040	34	615	0.14
15	230	50	1000	30	0.23	42	49	785	76	465	0.31
16	230	50	1000	26	0.20	41	49	485	98	285	0.39

U = Power supply · f = Frequency · n = Speed (rpm) · P_{ed} = Power consumption · I = Current draw · LpA_{in} = Sound pressure level intake side · LwA_{in} = Sound power level intake side
 q_v = Air flow · p_{fs} = Pressure increase

