

EC centrifugal fan - RadiPac

backward-curved, single-intake

for rail applications

R3G280-BD14-N2 ebmpapst Datasheet

sales@fansco.com

www.fansco.com

Limited partnership · Headquarters Muldingen

Amtsgericht (court of registration) Stuttgart · HRA 590344

General partner Elektrobau Muldingen GmbH · Headquarters Muldingen

Amtsgericht (court of registration) Stuttgart · HRB 590142

Nominal data

Type	R3G280-BD14-N2	
Motor	M3G084-GF	
Phase		3~
Nominal voltage	VAC	400
Nominal voltage range	VAC	380 .. 480
Frequency	Hz	50/60
Method of obtaining data		ml
Speed (rpm)	min ⁻¹	3140
Power consumption	W	900
Current draw	A	1.4
Min. ambient temperature	°C	-40
Max. ambient temperature	°C	60

ml = Max. load · me = Max. efficiency · fa = Free air · cs = Customer specification · ce = Customer equipment
Subject to change



Technical description

Size	280 mm
Motor size	84
Rotor surface	Painted black
Electronics housing material	Die-cast aluminum
Impeller material	Sheet aluminum
Inlet nozzle material	Sheet steel, galvanized
Number of blades	7
Direction of rotation	Clockwise, viewed toward rotor
Degree of protection	IP55
Insulation class	"F"
Moisture (F) / Environmental (H) protection class	H3
Max. permitted ambient temp. for motor (transport/storage)	+80 °C
Min. permitted ambient temp. for motor (transport/storage)	-40 °C
Installation position	Shaft horizontal or rotor on top
Condensation drainage holes	None
Mode	S1
Motor bearing	Ball bearing; (sealed)
Technical features	<ul style="list-style-type: none"> - Output 10 VDC, max. 10 mA - Alarm relay - Integrated PID controller - Run monitoring - Power limiter - Motor current limitation - Emergency operation - PFC, passive - RS-485 MODBUS-RTU - Soft start - EEPROM write cycles: 100,000 maximum - Control input 0-10 VDC / PWM - Control interface with SELV potential safely disconnected from the mains - Overvoltage detection - Thermal overload protection for electronics/motor - Line undervoltage / phase failure detection
Touch current according to IEC 60990 (measuring circuit Fig. 4, TN system)	<= 3.5 mA
Motor protection	Thermal overload protector (TOP) internally connected
With cable	Lateral
Protection class assignment	<p>I; If a protective earth is connected by the customer</p> <p>This component for installation may have several local protection classes. This information relates to this component's basic design.</p> <p>The final protection class is based on the component's intended installation and connection.</p>
Conformity with standards	EN 15085-1, CPC3: 2013; EN 45545-2, HL3: 2013 + A1:2015; EN 50155: 2008; EN 61373, Cat. 1B: 2010
Approval	EAC

EC centrifugal fan - RadiPac

backward-curved, single-intake

for rail applications

Comment

A prerequisite for operation is a Class 1 vehicle electrical system architecture according to EN 50533; if supply potential (e.g. 230 VAC) is passed through the alarm relay, the SELV signal wires lose their property of reinforced insulation and they then have only basic insulation

The SELV property (reinforced insulation) is not lost when voltages of up to 110 VDC are passed through the alarm relay.



Product drawing

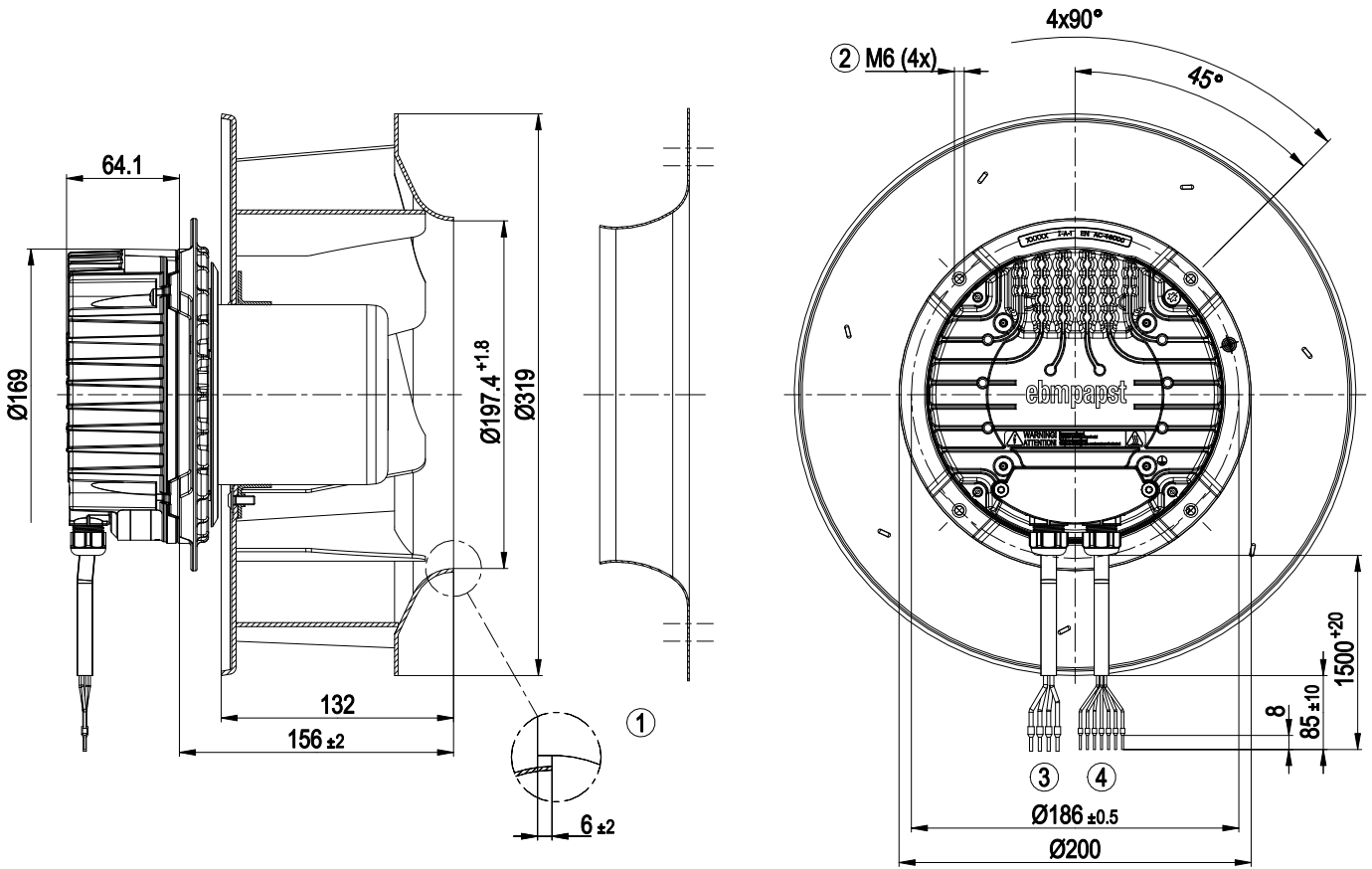

1	Accessory part: Inlet ring 28070-2-4013 not included in scope of delivery
2	Max. clearance for screw 10 mm
3	Cable, halogen-free, railway application EN 45545, 4G 1.5 mm ² 4x wire-end ferrule
4	Cable, halogen-free, railway application EN 45545, 7x 0.5 mm ² 7x wire-end ferrule

Accessory part

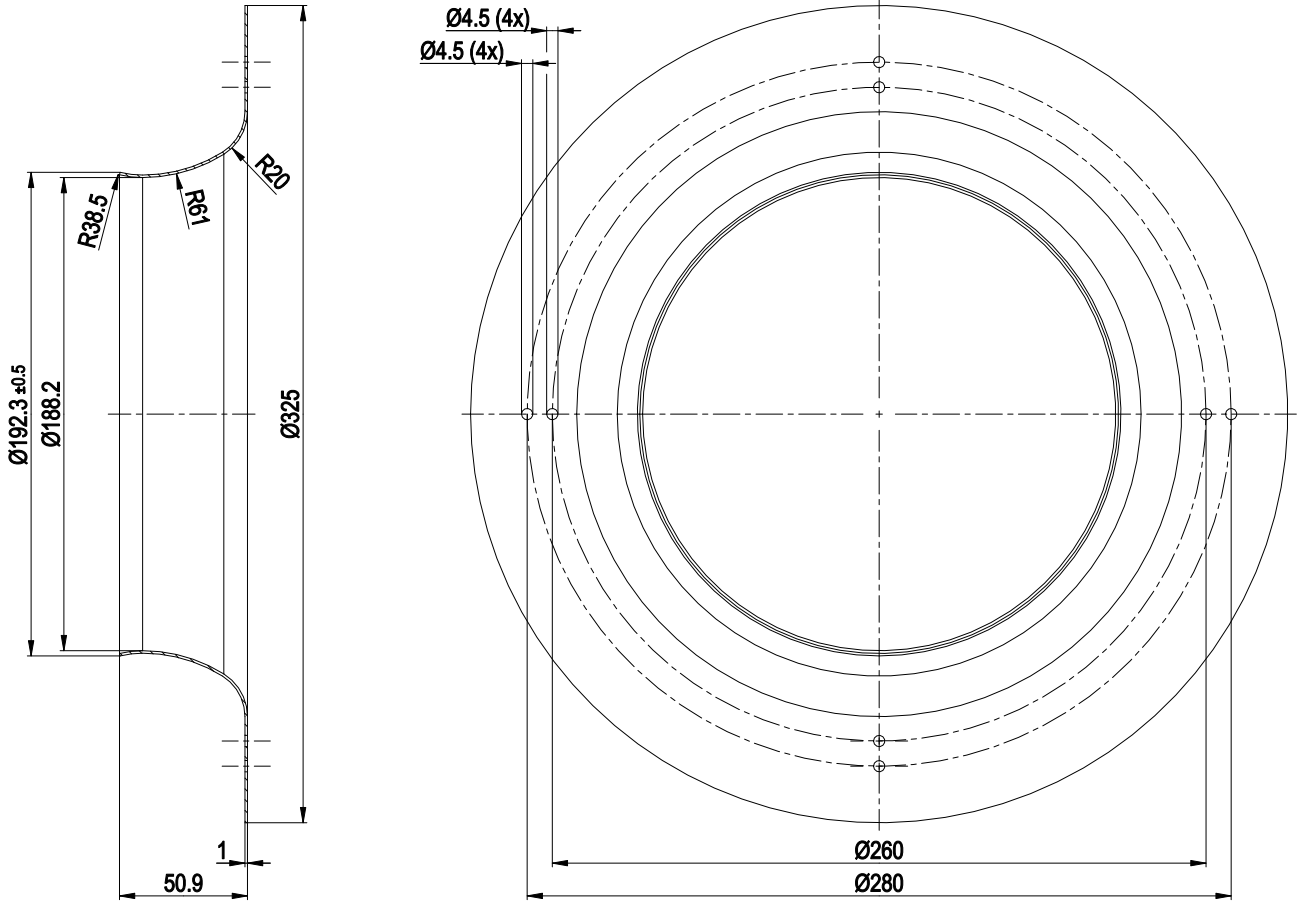

Inlet ring 28070-2-4013

EC centrifugal fan - RadiPac

backward-curved, single-intake
for rail applications

Connection diagram

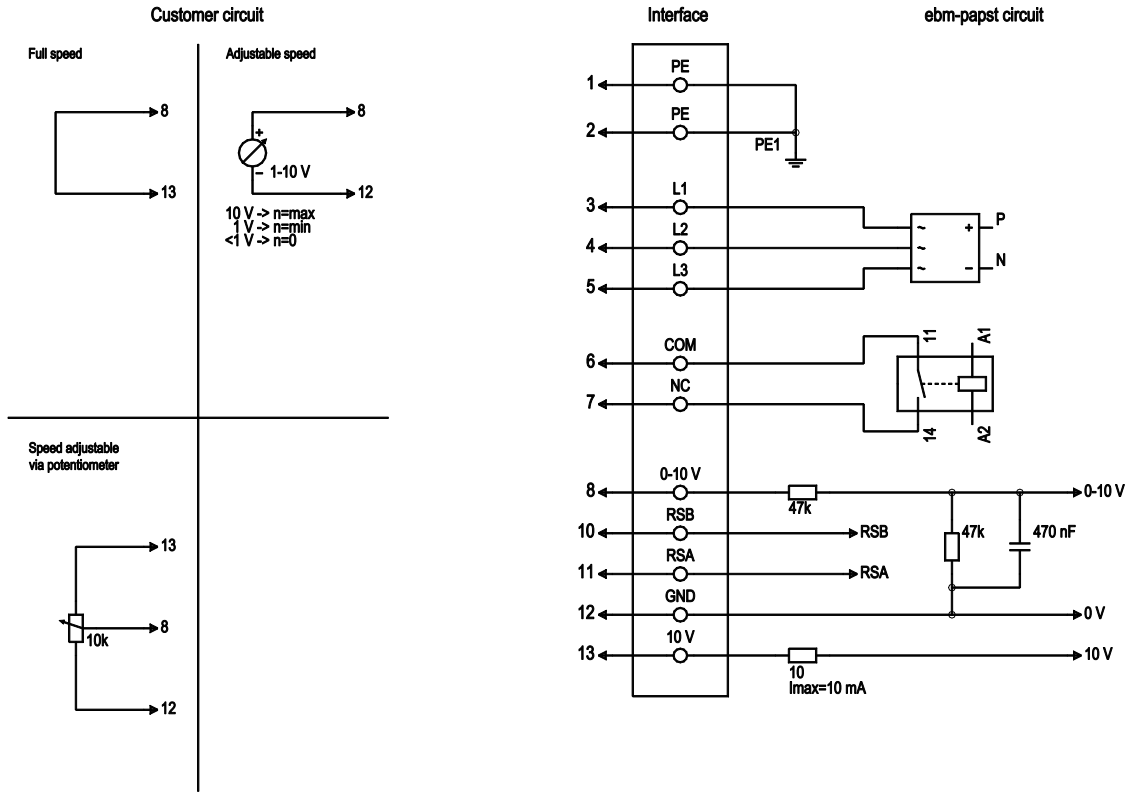

No.	Conn.	Designation	Color	Function/assignment
1	1	PE	green/yellow	Protective earth
1	2	PE	-	not brought out via wire
1	3	L1	black	Power supply, phase 50/60 Hz
1	4	L2	blue	Power supply, phase 50/60 Hz
1	5	L3	brown	Power supply, phase 50/60 Hz
2	6	COM	gray	Status relay, floating status contact, common connection, contact rating 250 VAC / max. 2 A (AC1), min. 1 mA / 5 VDC, reinforced insulation on control interface side, basic insulation on supply side according to EN 50124-1
2	7	NC	orange	Status relay, floating status contact, break for failure, contact rating 250 VAC / max. 2 A (AC1), min. 1 mA / 5 VDC, reinforced insulation on control interface side, basic insulation on supply side according to EN 50124-1
2	8	0-10V	yellow	Analog input (set value) SELV, 0-10 V, Ri = 100 kΩ, adjustable curve
2	10	RSB	brown	RS485 interface for MODBUS, RSB; SELV
2	11	RSA	white	RS485 interface for MODBUS, RSA; SELV
2	12	GND	blue	Reference ground for control interface, SELV
2	13	+10V	red	Fixed voltage output 10 VDC, +10 V ± 3%, max. 10 mA, short-circuit-proof, power supply for external devices (e.g. pot); SELV



Curves: Air performance 50 Hz

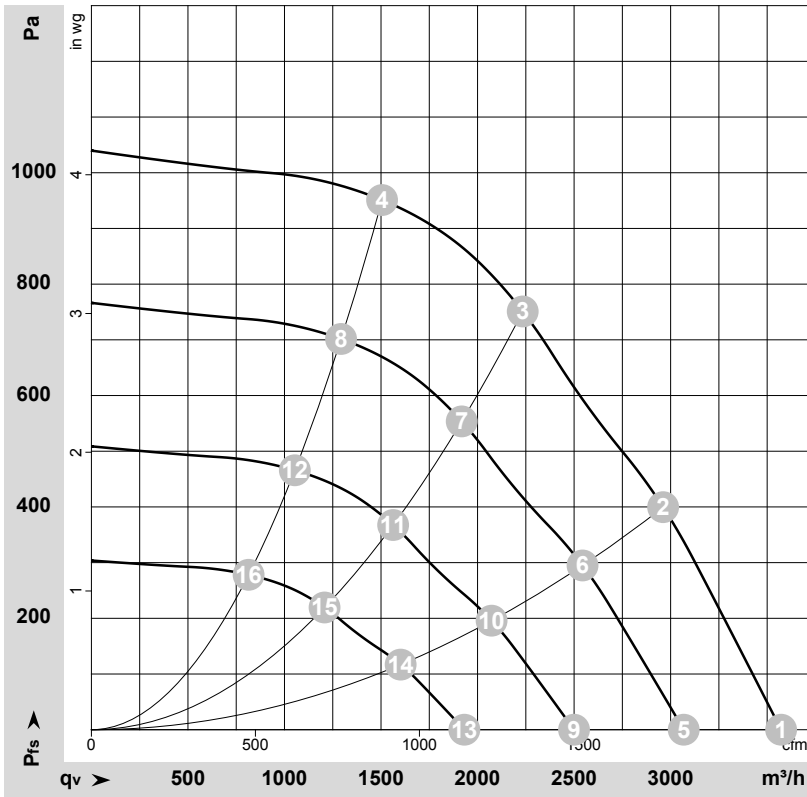

$\rho = 1.15 \text{ kg/m}^3 \pm 2 \%$

Measurement: LU-174830-1

Air performance measured according to ISO 5801 installation category A. For detailed information on the measurement setup, contact ebm-papst. Intake sound level: Sound power level according to ISO 13347 / sound pressure level measured at 1 m distance from fan axis. The values given are valid under the specified measuring conditions and may vary due to conditions of installation. For deviations from the standard configuration, the parameters have to be checked on the installed unit.

Measured values

	U	f	n	P _{ed}	I	LpA _{in}	LwA _{in}	LwA _{out}	q _v	P _{fs}	q _v	P _{fs}
	V	Hz	min ⁻¹	W	A	dB(A)	dB(A)	dB(A)	m ³ /h	Pa	cfm	in. wg
1	400	50	3140	735	1.14	77	86	92	3570	0	2100	0.00
2	400	50	3140	879	1.36	75	84	90	2960	400	1745	1.61
3	400	50	3140	900	1.40	72	81	86	2235	760	1315	3.05
4	400	50	3140	836	1.29	73	82	87	1505	950	885	3.81
5	400	50	2700	466	0.72	74	82	88	3070	0	1805	0.00
6	400	50	2700	557	0.86	71	80	86	2545	302	1495	1.21
7	400	50	2700	570	0.88	69	77	82	1920	559	1130	2.24
8	400	50	2700	530	0.82	70	78	83	1295	702	760	2.82
9	400	50	2200	252	0.39	68	77	83	2500	0	1470	0.00
10	400	50	2200	301	0.47	66	75	81	2075	201	1220	0.81
11	400	50	2200	309	0.48	63	72	77	1565	371	920	1.49
12	400	50	2200	287	0.44	65	73	78	1055	466	620	1.87
13	400	50	1700	116	0.18	62	70	76	1930	0	1135	0.00
14	400	50	1700	139	0.21	60	68	74	1600	120	945	0.48
15	400	50	1700	142	0.22	57	65	71	1210	222	710	0.89
16	400	50	1700	132	0.20	58	67	72	815	278	480	1.12

U = Voltage · f = Frequency · n = Speed (rpm) · P_{ed} = Power consumption · I = Current draw · LpA_{in} = Sound pressure level intake side · LwA_{in} = Sound power level intake side
 LwA_{out} = Sound power level outlet side · q_v = Air flow · P_{fs} = Pressure increase

