

R3G280-BB04-I9 ebmpapst Datasheet

sales@fansco.com

www.fansco.com

Limited partnership · Headquarters Muldingen
County court Stuttgart · HRA 590344

General partner Elektrobau Muldingen GmbH · Headquarters Muldingen
County court Stuttgart · HRB 590142

Nominal data

Type	R3G280-BB04-I9	
Motor	M3G084-DF	
Phase		1~
Nominal voltage	VAC	230
Nominal voltage range	VAC	200 .. 277
Frequency	Hz	50/60
Type of data definition		ml
State		prelim.
Speed (rpm)	min ⁻¹	2820
Power input	W	750
Current draw	A	3.3
Min. ambient temperature	°C	-25
Max. ambient temperature	°C	55

ml = Max. load · me = Max. efficiency · fa = Running at free air · cs = Customer specs · cu = Customer unit
Subject to alterations

Data in accordance with ecodesign regulation EU 327/2011

		Actual	Request 2015		
01 Overall efficiency η_{es}	%	64	36.8	09 Power input P_{ed}	kW 0.74
02 Measurement category		A		09 Air flow q_v	m ³ /h 2405
03 Efficiency category		Static		09 Pressure increase p_{fs}	Pa 652
04 Efficiency grade N		71.2	44	10 Speed (rpm) n	min ⁻¹ 2815
05 Variable speed drive		Yes		11 Specific ratio [*]	1.01

Data definition with optimum efficiency.
The ErP data is determined using a motor-impeller combination in a standardised measurement configuration.

^{*} Specific ratio = $1 + p_{fs} / 100\,000\text{ Pa}$

LU-176655



Technical features

Mass	0 kg
Size	280 mm
Surface of rotor	Coated in black
Material of electronics housing	Die-cast aluminium
Material of impeller	Aluminium sheet
Number of blades	7
Direction of rotation	Clockwise, seen on rotor
Type of protection	IP 55
Insulation class	"F"
Humidity (F)/environmental protection class (H)	H1
Note ambient temperature	Occasional start-up between -40°C and -25°C is permissible. For continuous operation at ambient temperatures below -25°C (e.g. refrigeration applications) we recommend our fan version with special low-temperature bearings.
Max. permissible ambient motor temp. (transp./ storage)	+80 °C
Min. permissible ambient motor temp. (transp./storage)	-40 °C
Mounting position	Shaft horizontal or rotor on bottom; rotor on top on request
Condensate discharge holes	Rotor-side
Operation mode	S1
Motor bearing	Ball bearing
Technical features	<ul style="list-style-type: none"> - Output 10 VDC, max. 10 mA - Operation and alarm display - Alarm relay - Integrated PID controller - Output limit - Motor current limit - PFC, active - RS485 MODBUS RTU - Soft start - Control input 0-10 VDC / PWM - Control interface with SELV potential safely disconnected from the mains - Over-temperature protected electronics / motor - Line undervoltage / phase failure detection
Touch current acc. IEC 60990 (measuring network Fig. 4, TN system)	<= 3.5 mA
Motor protection	Thermal overload protector (TOP) wired internally
Cable exit	Variable
Protection class	I (if protective earth is connected by customer)
Product conforming to standard	EN 61800-5-1; EN 60335-1; CE
Approval	C22.2 Nr.77 + CAN/CSA-E60730-1; UL 1004-7 + 60730

Product drawing

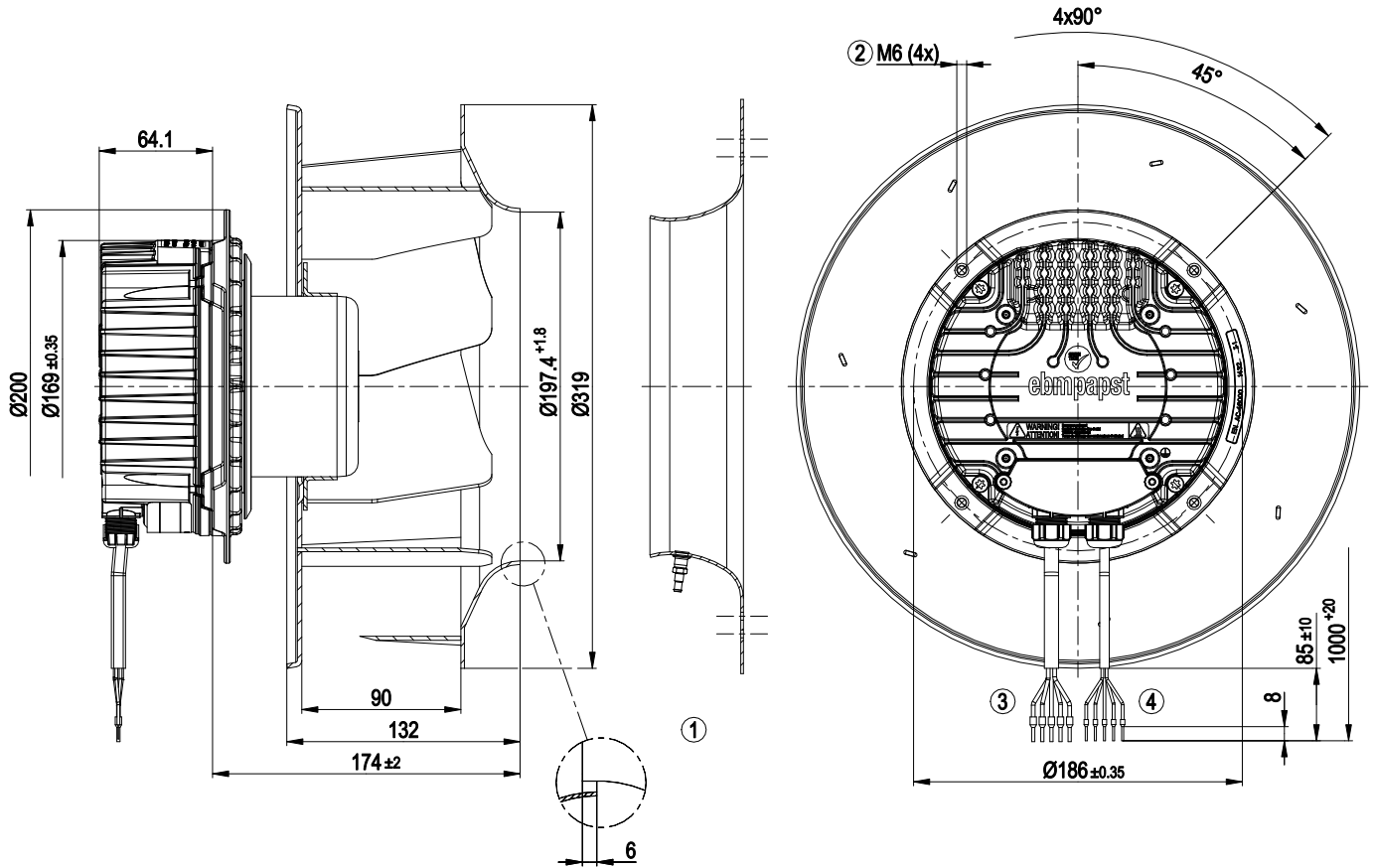

1	Accessory part: Inlet nozzle 28075-2-4013 with pressure tap (k-factor: 93) not included in scope of delivery
2	Thread reach max. 16 mm
3	Connection line PVC AWG18, 5x crimped core-end sleeves
4	Connection line PVC AWG22, 5x crimped core-end sleeves

Accessory part

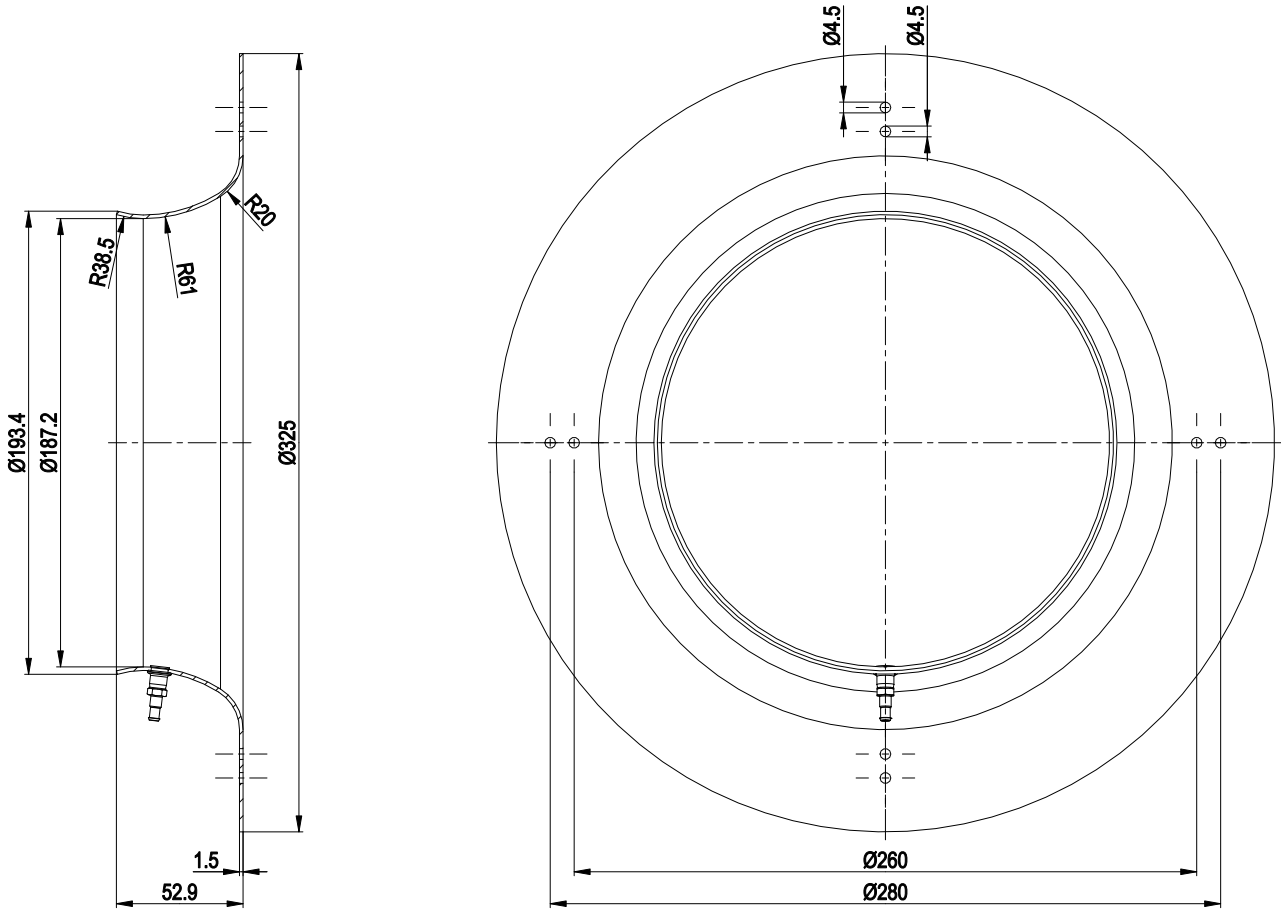

Inlet nozzle 28075-2-4013 with pressure tap not included in scope of delivery

Connection screen

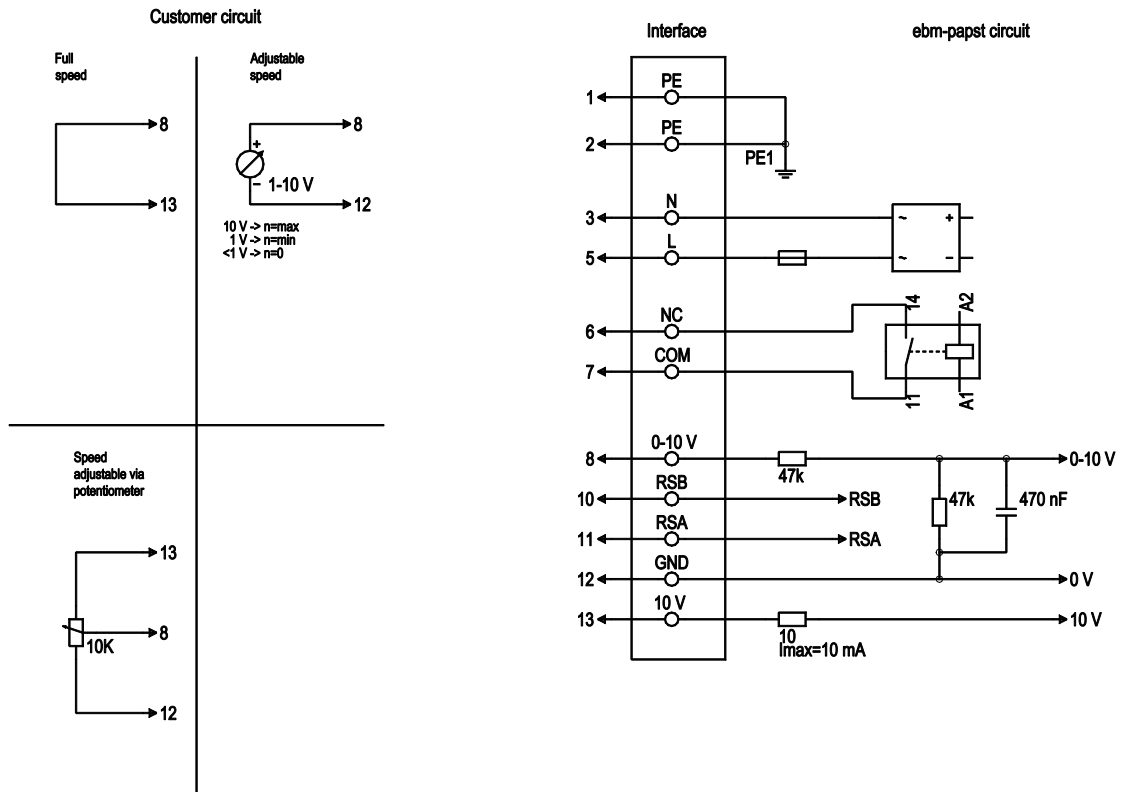

No.	Conn.	Designation	Colour	Function / assignment
1	1, 2	PE	green/yellow	Protective earth
1	3	N	blue	Supply voltage, neutral conductor, 50/60 Hz
1	5	L	black	Supply voltage, phase, 50/60 Hz
1	6	NC	white 1	Status relay, floating status contact; break for failure, contact rating 250 VAC / 2A (AC1) min. 10 mA, basic insulation on mains side and reinforced insulation on control interface side
1	7	COM	white 2	Status relay, floating status contact; common connection, contact rating 250 VAC / 2A (AC1) min. 10 mA, basic insulation on mains side and reinforced insulation on control interface side
2	8	0-10V	yellow	Analogue input 1 (set value); 0-10 V; Ri=100kΩ; parametrisable curve
2	10	RSB	brown	RS485 interface for Modbus, RSB
2	11	RSA	white	RS485 interface for Modbus, RSA
2	12	GND	blue	Reference ground for control interface, SELV
2	13	+10V	red	Fixed voltage output 10 VDC; +10 V +/-3%; max. 10 mA; short-circuit-proof; power supply for external devices (e.g. potentiometer)

Charts: Air flow 50 Hz

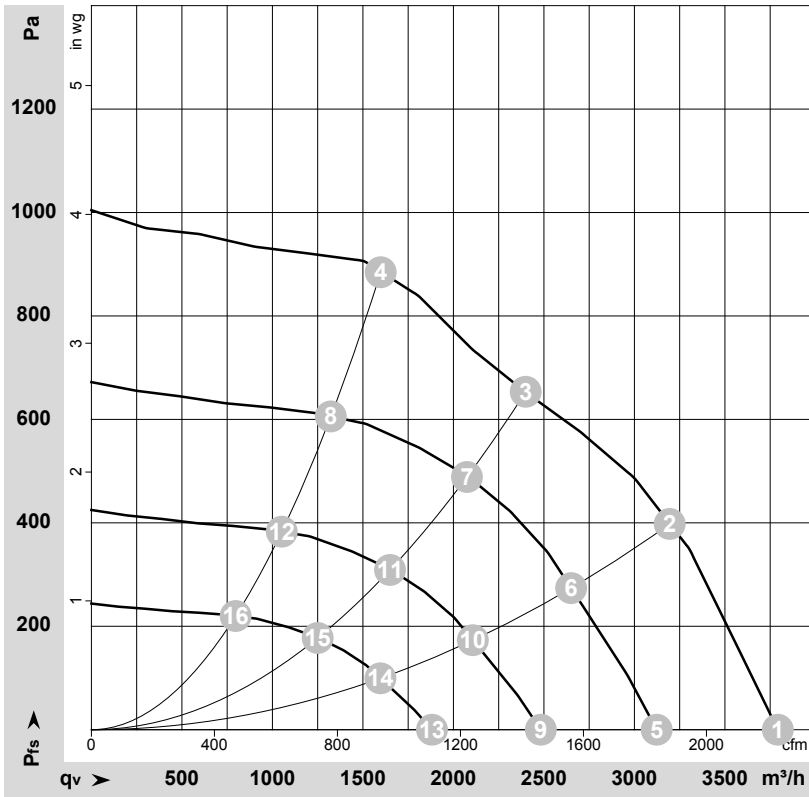

$\rho = 1.15 \text{ kg/m}^3 \pm 2 \%$

Measurement: LU-176655-1

Air performance measured as per ISO 5801 Installation category A. For detailed information on the measuring set-up, please contact ebmpapst. Suction-side noise levels: LwA measured as per ISO 13347 / LpA measured with 1m distance to fan axis. The values given are valid under the measuring conditions mentioned above and may vary according to the actual installation situation. With any deviation from the standard set-up, the specific values have to be checked and reviewed with the unit installed.

Measured values

	U	f	n	P _{ed}	I	LpA _{in}	LwA _{in}	q _v	P _{fs}	q _v	P _{fs}
	V	Hz	min ⁻¹	W	A	dB(A)	dB(A)	m ³ /h	Pa	cfm	inH ₂ O
1	230	50	2940	560	2.46	76	83	3790	0	2230	0.00
2	230	50	2940	730	3.19	72	79	3195	400	1880	1.61
3	230	50	2820	750	3.30	70	77	2400	650	1415	2.61
4	230	50	2940	746	3.26	73	81	1600	885	940	3.55
5	230	50	2440	313	1.37			3125	0	1840	0.00
6	230	50	2440	416	1.82			2650	274	1560	1.10
7	230	50	2440	485	2.12			2075	491	1220	1.97
8	230	50	2440	422	1.85			1325	606	780	2.43
9	230	50	1940	157	0.69			2485	0	1460	0.00
10	230	50	1940	209	0.91			2105	173	1240	0.69
11	230	50	1940	244	1.06			1650	310	970	1.24
12	230	50	1940	212	0.93			1050	383	620	1.54
13	230	50	1470	68	0.30			1880	0	1105	0.00
14	230	50	1470	91	0.40			1595	99	940	0.40
15	230	50	1470	106	0.46			1250	178	735	0.71
16	230	50	1470	92	0.40			795	220	470	0.88
1	230	50	2965	560	2.46	76	84	3790	0	2230	0.00
2	230	50	2945	730	3.19	71	79	3195	399	1880	1.60
3	230	50	2815	744	3.25	70	77	2400	652	1410	2.62
4	230	50	2950	746	3.26	73	81	1600	886	940	3.56
5	230	50	2440	313	1.37	71	79	3125	0	1840	0.00
6	230	50	2440	416	1.82	67	74	2650	274	1560	1.10
7	230	50	2440	485	2.12			2075	491	1220	1.97
8	230	50	2440	422	1.85			1325	606	780	2.43
9	230	50	1940	157	0.69	65	73	2485	0	1460	0.00

