

R3G280-AU11-C8

# EC centrifugal fan

backward curved, single inlet



R3G280-AU11-C8 ebmpapst Datasheet FansCo

sales@fansco.com

www.fansco.com

## Nominal data

Type	R3G280-AU11-C8	
Motor	M3G084-GF	
Phase		3~
Nominal voltage	VAC	400
Nominal voltage range	VAC	380 .. 480
Frequency	Hz	50/60
Type of data definition		ml
Speed (rpm)	min <sup>-1</sup>	3100
Power input	W	1000
Current draw	A	1.6
Min. ambient temperature	°C	-25
Max. ambient temperature	°C	60

ml = Max. load · me = Max. efficiency · fa = Running at free air · cs = Customer specs · cu = Customer unit  
Subject to alterations

## Data according to ErP directive

		Actual	Request 2015
01 Overall efficiency $\eta_{es}$	%	61.4	51.5
02 Measurement category		A	
03 Efficiency category		Static	
04 Efficiency grade N		71.9	62
05 Variable speed drive		Yes	

Data definition with optimum efficiency.  
The ErP data is determined using a motor-impeller combination in a standardised measurement configuration.

09 Power input $P_{ed}$	kW	0.99
09 Air flow $q_v$	m <sup>3</sup> /h	2675
09 Pressure increase $p_{fs}$	Pa	758
10 Speed (rpm) $n$	min <sup>-1</sup>	3115
11 Specific ratio*		1.01

\* Specific ratio =  $1 + p_{fs} / 100\,000\text{ Pa}$

LU-130335



## Technical features

<b>Mass</b>	6.6 kg
<b>Size</b>	280 mm
<b>Surface of rotor</b>	Coated in black
<b>Material of electronics housing</b>	Die-cast aluminium
<b>Material of impeller</b>	Aluminium sheet
<b>Number of blades</b>	7
<b>Direction of rotation</b>	Clockwise, seen on rotor
<b>Type of protection</b>	IP 54
<b>Insulation class</b>	"B"
<b>Humidity (F)/environmental protection class (H)</b>	F3-1
<b>Max. permissible ambient motor temp. (transp./ storage)</b>	+80 °C
<b>Min. permissible ambient motor temp. (transp./storage)</b>	-40 °C
<b>Mounting position</b>	Shaft horizontal or rotor on bottom; rotor on top on request
<b>Condensate discharge holes</b>	Rotor-side
<b>Operation mode</b>	S1
<b>Motor bearing</b>	Ball bearing
<b>Technical features</b>	<ul style="list-style-type: none"> <li>- Output 10 VDC, max. 10 mA</li> <li>- Output 20 VDC, max. 50 mA</li> <li>- Output for slave 0-10 V</li> <li>- Input for sensor 0-10 V or 4-20 mA</li> <li>- External 24 V input (programming)</li> <li>- Alarm relay</li> <li>- Integrated PID controller</li> <li>- Output limit</li> <li>- Motor current limit</li> <li>- PFC, passive</li> <li>- RS485 MODBUS RTU</li> <li>- Soft start</li> <li>- Control input 0-10 VDC / PWM</li> <li>- Control interface with SELV potential safely disconnected from the mains</li> <li>- Over-temperature protected electronics / motor</li> <li>- Line undervoltage / phase failure detection</li> </ul>
<b>EMC interference immunity</b>	Acc. to EN 61000-6-2 (industrial environment)
<b>EMC harmonics</b>	Acc. to EN 61000-3-2/3
<b>EMC interference emission</b>	Acc. to EN 61000-6-3 (household environment)
<b>Touch current acc. IEC 60990 (measuring network Fig. 4, TN system)</b>	<= 3.5 mA
<b>Electrical leads</b>	Via terminal box
<b>Motor protection</b>	Thermal overload protector (TOP) wired internally
<b>Protection class</b>	I (if protective earth is connected by customer at the connection point of the housing)
<b>Product conforming to standard</b>	EN 61800-5-1; CE
<b>Approval</b>	CCC; UL 1004-7 + 60730; EAC; C22.2 Nr.77 + CAN/CSA-E60730-1

Product drawing

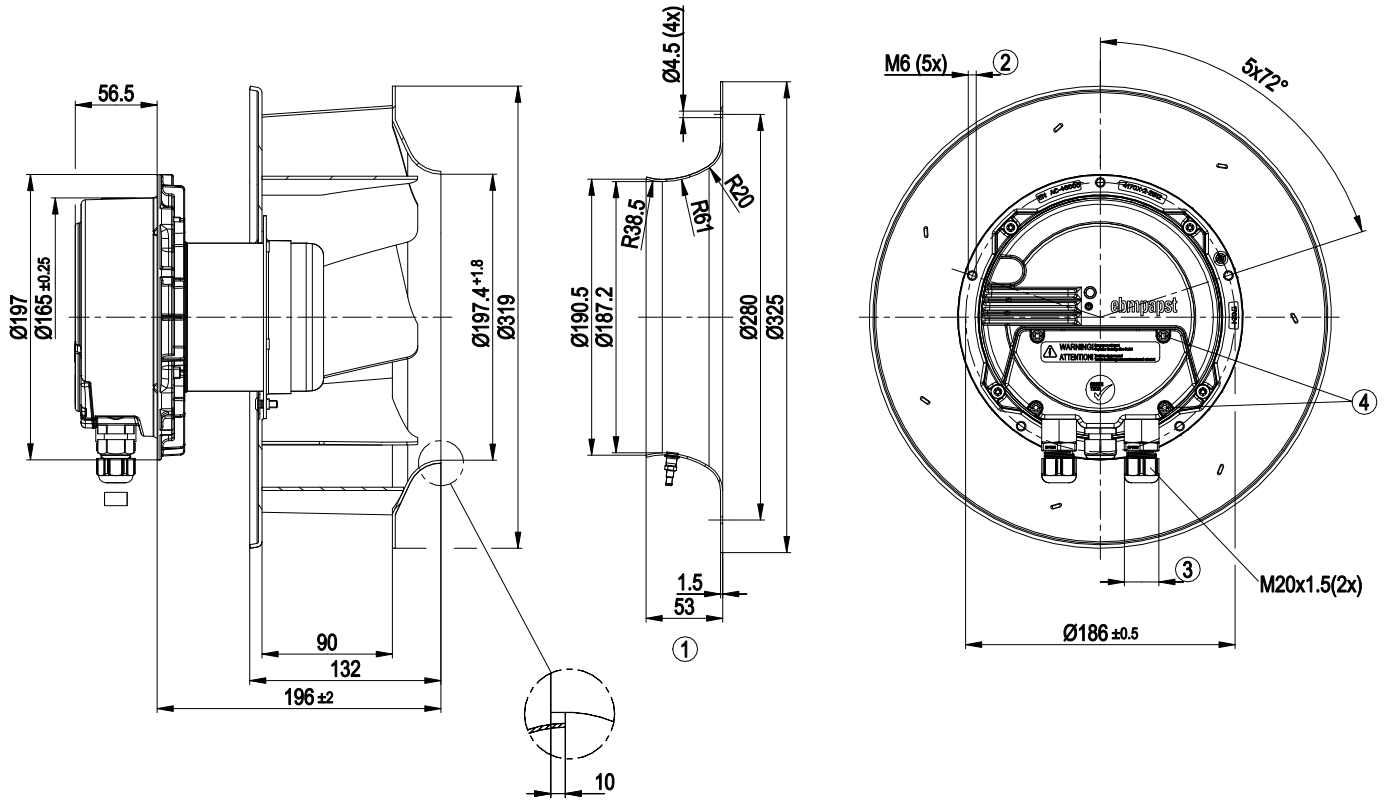

1	Accessory part: inlet nozzle 28075-2-4013 with a pressure tap (k-factor: 93) not included in scope of delivery
2	Depth of screw max. 16 mm
3	Cable diameter min. 6 mm, max. 12 mm, tightening torque 2.5±0.4 Nm
4	Tightening torque 3.5±0.5 Nm

## Connection screen

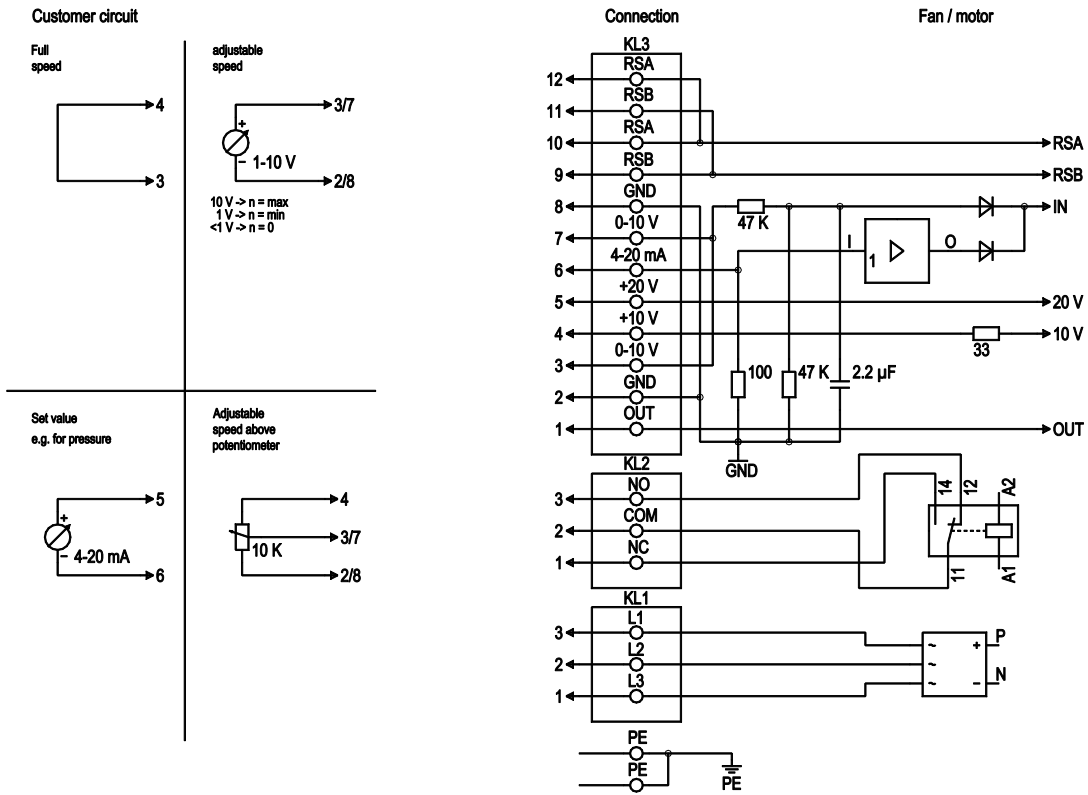

No.	Conn.	Designation	Function / assignment
PE		PE	Protective earth connection
KL1	1, 2, 3	L1, L2, L3	Supply voltage, voltage range (see type plate), 50/60 Hz
KL2	1	NC	Floating status contact, break with error
KL2	2	COM	Floating status contact, changeover contact, common connection (2 A, max. 250 VAC, min. 10 mA, AC1)
KL2	3	NO	Floating status contact, close with error
KL3	1	OUT	Analogue output, 0-10 VDC, max. 3 mA, SELV, Output of the actual motor duty cycle (PWM): 1 V corresponds to 10% PWM, 10 V correspond to 100% PWM.
KL3	2, 8	GND	Signal ground for control interface, SELV
KL3	3, 7	0-10 V	Set value / actual sensor value input 0-10 VDC, impedance 100 kΩ only as alternative to 4-20 mA input, SELV
KL3	4	+10 V	Voltage output 10 VDC (+/-3%), max. 10 mA, power supply for external devices (e.g. potentiometer), SELV
KL3	5	+20 V	Voltage output 20 VDC (+25%/-10%), max. 50 mA, supply voltage for external devices (e.g. sensors), SELV
KL3	6	4-20 mA	Set value / actual sensor value input 4-20 mA, impedance 100 Ω, only as alternative to 0-10 V input, SELV
KL3	9, 11	RSB	RS485 interface for MODBUS, RSB
KL3	10, 12	RSA	RS485 interface for MODBUS, RSA

## Charts: Air flow 50 Hz

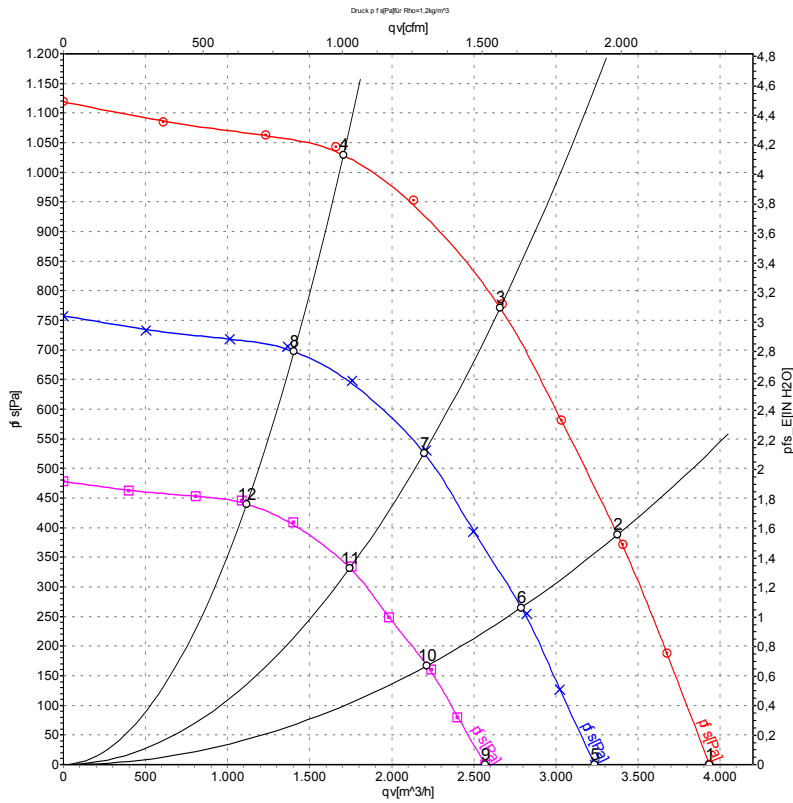

Measurement: LU-130335-1

Air performance measured as per ISO 5801 Installation category A. For detailed information on the measuring set-up, please contact ebm-papst. Suction-side noise levels: LwA measured as per ISO 13347 / LpA measured with 1m distance to fan axis. The values given are valid under the measuring conditions mentioned above and may vary according to the actual installation situation. With any deviation from the standard set-up, the specific values have to be checked and reviewed with the unit installed.

## Measured values

	U	f	n	P <sub>ed</sub>	I	LpA <sub>in</sub>	LwA <sub>in</sub>	LwA <sub>out</sub>	q <sub>v</sub>	P <sub>fs</sub>	q <sub>v</sub>	P <sub>fs</sub>
	V	Hz	min <sup>-1</sup>	W	A	dB(A)	dB(A)	dB(A)	m <sup>3</sup> /h	Pa	cfm	inH <sub>2</sub> O
1	400	50	3100	645	1.04	78	86	93	3935	0	2315	0.00
2	400	50	3100	852	1.35	75	83	90	3375	390	1985	1.57
3	400	50	3100	1000	1.60	72	80	86	2660	775	1565	3.11
4	400	50	3100	921	1.46	76	83	89	1705	1030	1005	4.14
5	400	50	2575	358	0.58	74	82	88	3235	0	1905	0.00
6	400	50	2575	482	0.76	71	79	85	2790	269	1640	1.08
7	400	50	2575	562	0.89	68	76	82	2195	534	1295	2.14
8	400	50	2575	514	0.82	71	79	84	1405	700	825	2.81
9	400	50	2045	180	0.29	69	77	83	2570	0	1515	0.00
10	400	50	2045	242	0.38	66	74	80	2215	170	1305	0.68
11	400	50	2045	282	0.45	63	71	77	1745	337	1025	1.35
12	400	50	2045	257	0.41	66	74	79	1115	442	655	1.77

U = Supply voltage · f = Frequency · n = Speed (rpm) · P<sub>ed</sub> = Power input · I = Current draw · LpA<sub>in</sub> = Sound pressure level inlet side · LwA<sub>in</sub> = Sound power level inlet side · LwA<sub>out</sub> = Sound power level outlet side  
 q<sub>v</sub> = Air flow · p<sub>fs</sub> = Pressure increase

