

R3G280-AU06-B3

EC centrifugal fan

backward-curved, single-intake



R3G280-AU06-B3 ebmpapst Datasheet
sales@fansco.com
www.fansco.com

Limited partnership · Headquarters Mulfingen
Amtsgericht (court of registration) Stuttgart · HRA 590344

General partner Elektrobau Mulfingen GmbH · Headquarters Mulfingen
Amtsgericht (court of registration) Stuttgart · HRB 590142

Nominal data

Type	R3G280-AU06-B3	
Motor	M3G084-GF	
Phase		1~
Nominal voltage	VAC	230
Nominal voltage range	VAC	200 .. 277
Frequency	Hz	50/60
Method of obtaining data		ml
Speed (rpm)	min ⁻¹	2800
Power consumption	W	715
Current draw	A	3.1
Min. ambient temperature	°C	-25
Max. ambient temperature	°C	40

ml = Max. load · me = Max. efficiency · fa = Free air · cs = Customer specification · ce = Customer equipment
Subject to change

Data according to Commission Regulation (EU) 327/2011 (EN 17166)

		Actual	Req. 2015			
01 Overall efficiency η_{es}	%	58.8	50.1	09 Power consumption P_{ed}	kW	0.73
02 Measurement category		A		09 Air flow q_v	m ³ /h	1925
03 Efficiency category		Static		09 Pressure increase p_{fs}	Pa	737
04 Efficiency grade N		70.7	62	10 Speed (rpm) n	min ⁻¹	2825
05 Variable speed drive		Yes		11 Specific ratio*		1.01

Data obtained at optimum efficiency level.

The ErP data is determined using a motor-impeller combination in a standardized measurement setup.

* Specific ratio = $1 + p_{fs} / 100\,000\text{ Pa}$

LU-162089



Technical description

Weight	6.6 kg
Size	280 mm
Motor size	84
Rotor surface	Painted black
Electronics housing material	Die-cast aluminum
Impeller material	Sheet aluminum
Number of blades	7
Direction of rotation	Clockwise, viewed toward rotor
Degree of protection	IP54
Insulation class	"B"
Moisture (F) / Environmental (H) protection class	H1
Max. permitted ambient temp. for motor (transport/storage)	+80 °C
Min. permitted ambient temp. for motor (transport/storage)	-40 °C
Installation position	Shaft horizontal or rotor on bottom; rotor on top on request
Condensation drainage holes	On rotor side
Mode	S1
Motor bearing	Ball bearing
Technical features	<ul style="list-style-type: none"> - Output 10 VDC, max. 10 mA - Output 20 VDC, max. 50 mA - Output for slave 0-10 V - Input for sensor 0-10 V or 4-20 mA - Alarm relay - Motor current limitation - PFC, active - RS-485 MODBUS-RTU - Soft start - Control input 0-10 VDC / PWM - Control interface with SELV potential safely disconnected from the mains - Thermal overload protection for electronics/motor - Line undervoltage / phase failure detection
EMC immunity to interference	According to EN 61000-6-2 (industrial environment)
EMC circuit feedback	According to EN 61000-3-2/3
EMC interference emission	According to EN 61000-6-4 (industrial environment)
Touch current according to IEC 60990 (measuring circuit Fig. 4, TN system)	<= 3.5 mA
Electrical hookup	Connector with cable
Motor protection	Thermal overload protector (TOP) internally connected
With cable	Variable
Protection class	I (with customer connection of protective earth)
Conformity with standards	EN 61800-5-1; CE

Product drawing

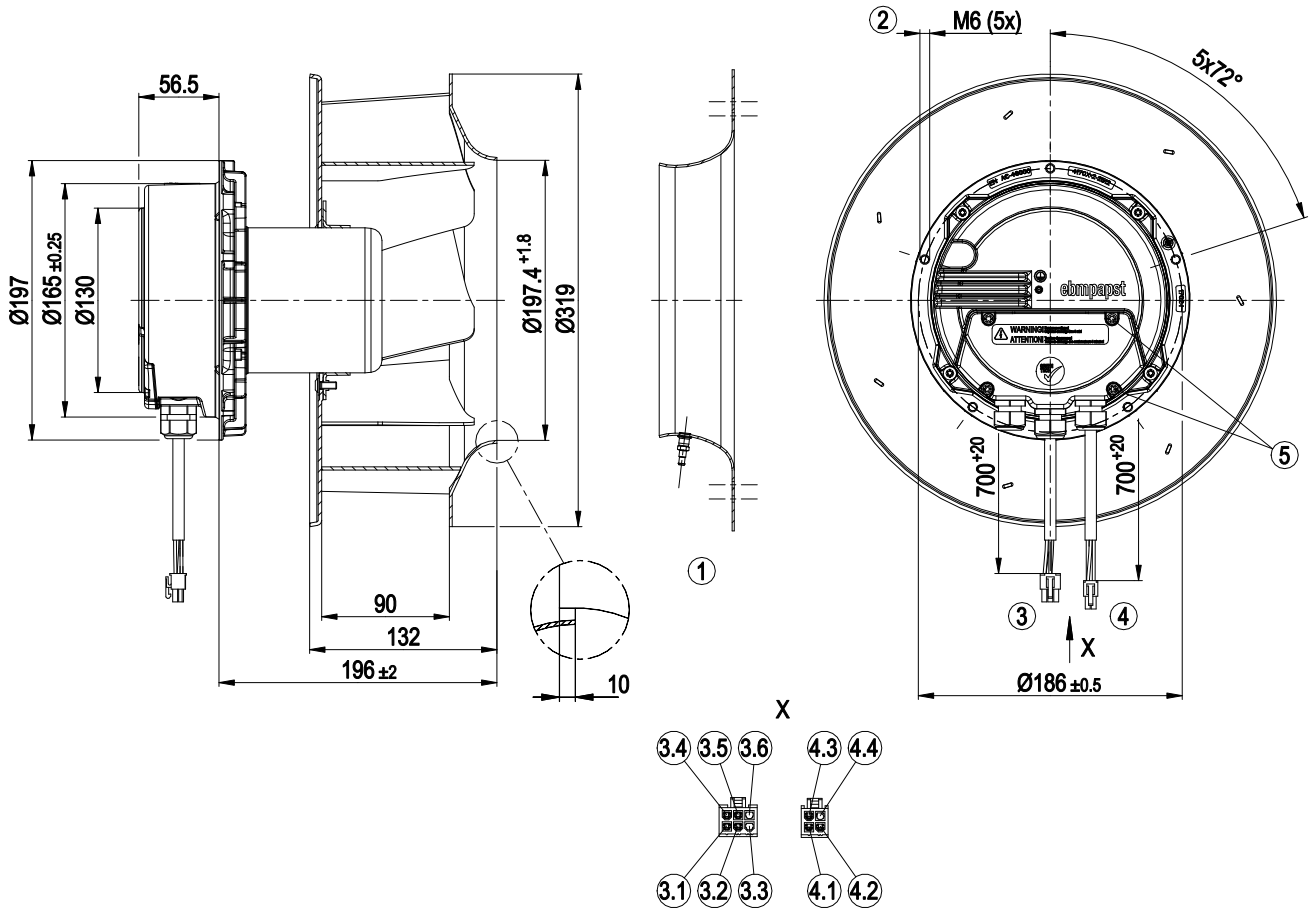

1	Accessory part: inlet ring 28075-2-4013 with pressure tap (k-factor:93) not included in scope of delivery
2	Max. clearance for screw 16 mm
3	Cable PVC AWG22 with 6-pole connector housing tyco 1586765-6, 4x socket tyco 794956-3
3.1	0-10 V PWM (yellow)
3.2	GND (orange)
3.3	not used
3.4	NC (black)
3.5	COM (red)
3.6	not used
4	Cable PVC AWG18 with 4-pole connector housing tyco 1586765-4, 3x socket tyco 794956-3
4.1	L (brown)
4.2	N (blue)
4.3	PE (green/yellow)
4.4	not used
5	Tightening torque 3.5 ± 0.5 Nm

Accessory part

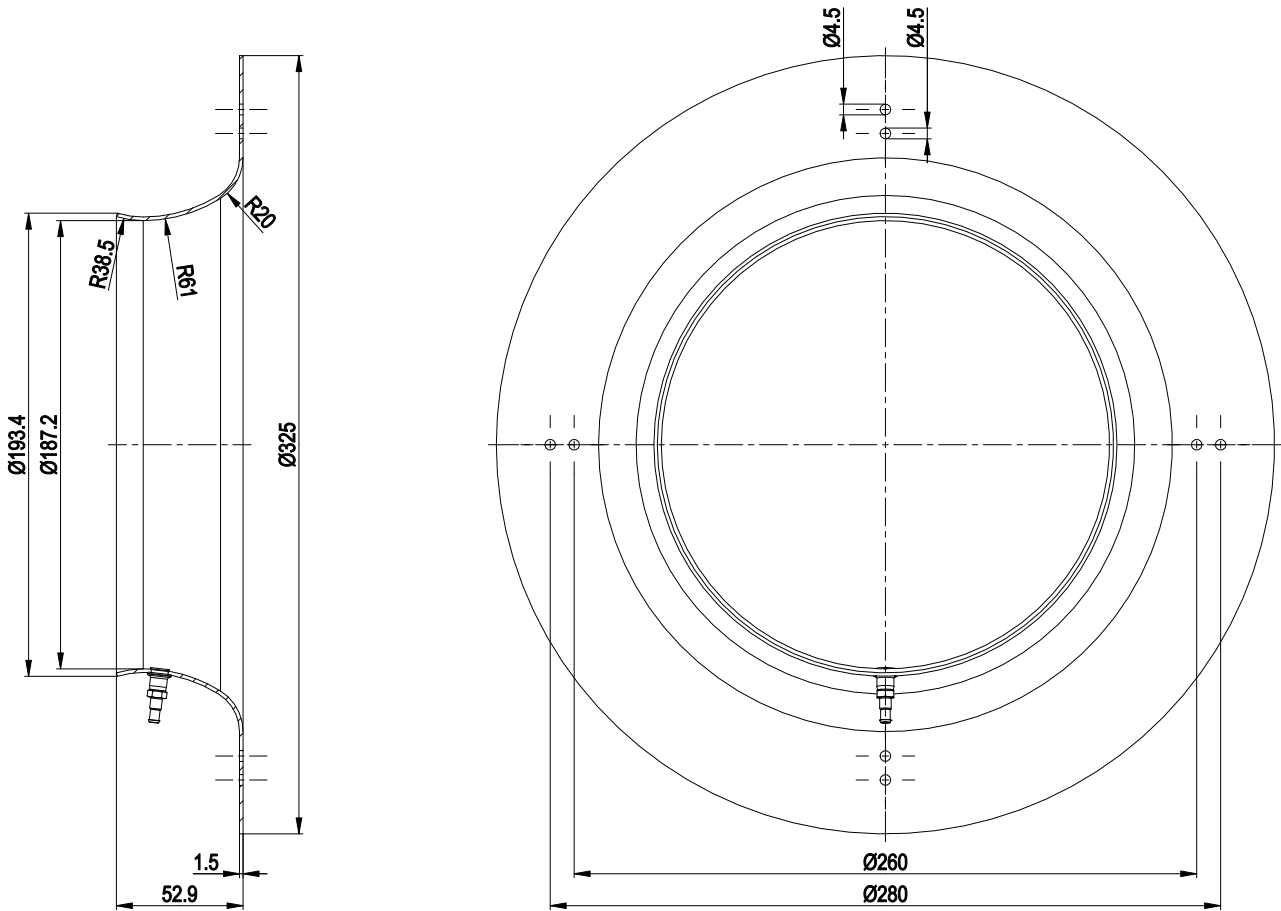

Inlet ring 28075-2-4013 with pressure tap not included in scope of delivery

Connection diagram

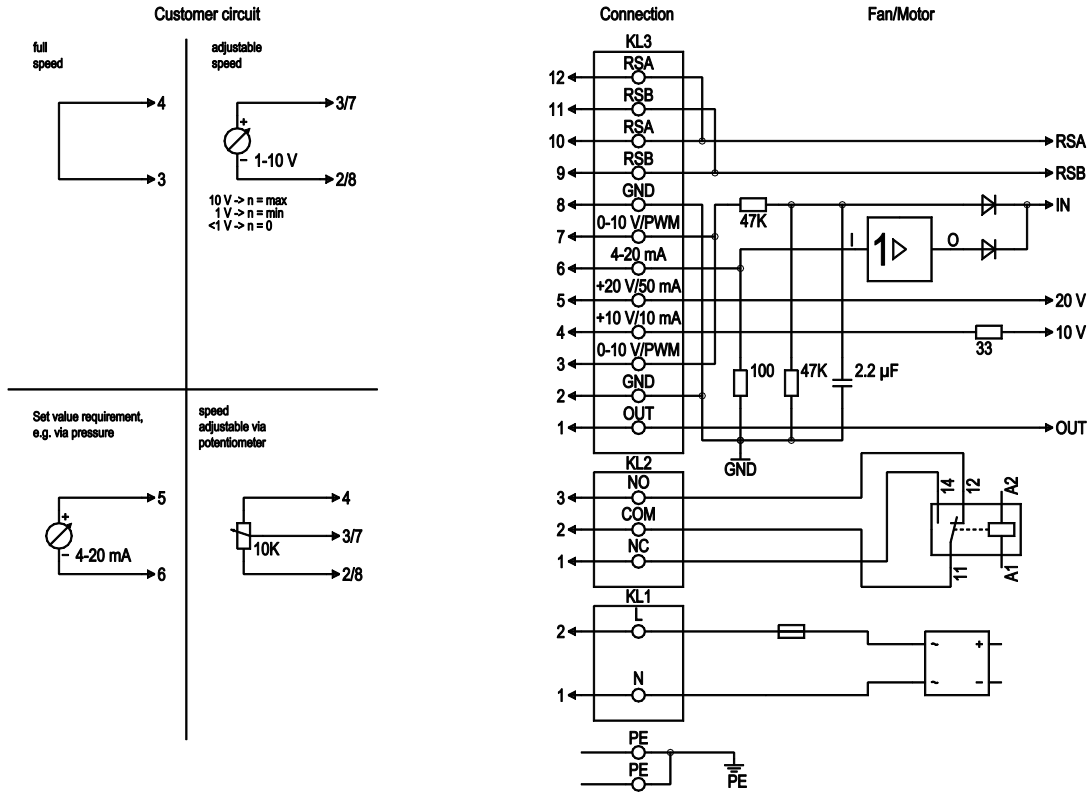

No.	Conn.	Designation	Function/assignment
PE	-	PE	Protective earth terminal
KL1	1, 2	N, L	Power supply 50/60 Hz
KL2	1	NC	Floating status contact, break for failure
KL2	2	COM	Floating status contact, changeover contact, common connection (2 A, max. 250 VAC, min. 10 mA, AC1)
KL2	3	NO	not brought out via wire
KL3	1	OUT	not brought out via wire
KL3	2, 8	GND	Reference ground for control interface, SELV
KL3	3, 7	0-10 V	Use control/current sensor value input 0-10 VDC, impedance 100 kΩ only as alternative to 4-20 mA input, SELV
KL3	4	+10 V	not brought out via wire
KL3	5	+20 V	not brought out via wire
KL3	6	4-20 mA	not brought out via wire
KL3	9, 11	RSB	not brought out via wire
KL3	10, 12	RSA	not brought out via wire



Curves: Air performance 50 Hz

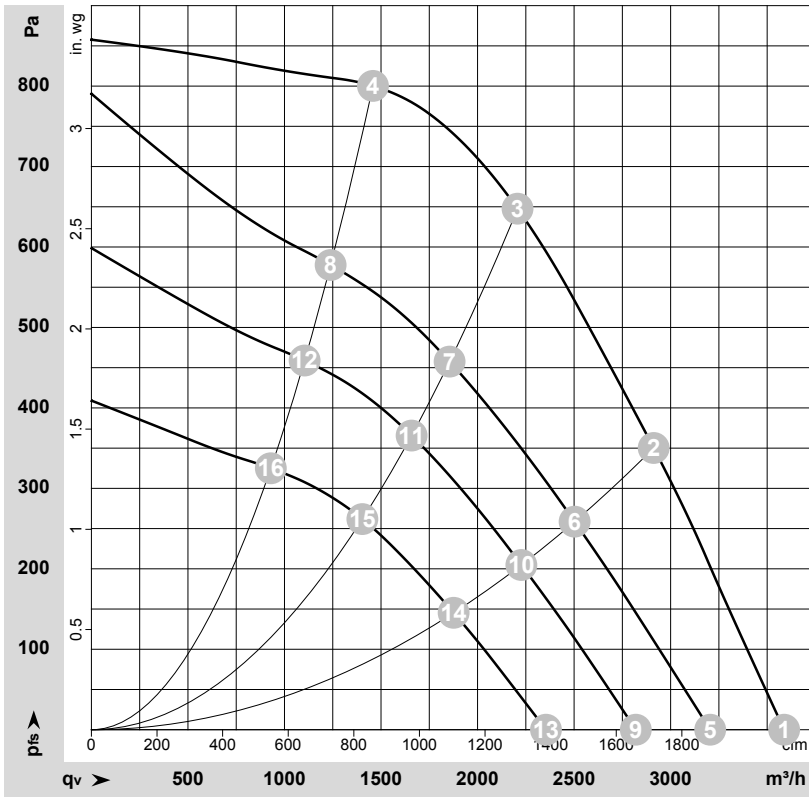

$\rho = 1.15 \text{ kg/m}^3 \pm 2 \%$

Measurement: LU-162089-1

Air performance measured according to ISO 5801 installation category A. For detailed information on the measurement setup, contact ebmpapst. Intake sound level: Sound power level according to ISO 13347 / sound pressure level measured at 1 m distance from fan axis. The values given are valid under the specified measuring conditions and may vary due to conditions of installation. For deviations from the standard configuration, the parameters have to be checked on the installed unit.

Measured values

	Wired	U	f	n	P _{ed}	I	LpA _{in}	LwA _{in}	LwA _{out}	q _v	p _{fs}	q _v	p _{fs}
		V	Hz	min ⁻¹	W	A	dB(A)	dB(A)	dB(A)	m ³ /h	Pa	cfm	in. wg
1	1~	230	50	2825	501	2.23	78	85	90	3590	0	2110	0.00
2	1~	230	50	2810	638	2.82	73	81	86	2910	350	1715	1.41
3	1~	230	50	2800	715	3.10	72	80	86	2205	650	1300	2.61
4	1~	230	50	2820	676	2.99	73	82	87	1460	800	860	3.21
5	1~	230	50	2515	357	1.63	76	82	87	3205	0	1885	0.00
6	1~	230	50	2420	404	1.82	70	77	83	2505	259	1475	1.04
7	1~	230	50	2360	433	1.94	68	76	82	1855	459	1090	1.84
8	1~	230	50	2405	411	1.85	69	77	83	1240	579	730	2.32
9	1~	230	50	2220	249	1.19	72	79	84	2820	0	1660	0.00
10	1~	230	50	2160	284	1.33	67	74	80	2225	205	1310	0.82
11	1~	230	50	2110	309	1.43	66	74	80	1660	367	975	1.47
12	1~	230	50	2150	288	1.35	66	74	80	1105	460	650	1.85
13	1~	230	50	1860	151	0.83	68	75	80	2355	0	1385	0.00
14	1~	230	50	1815	176	0.92	63	71	77	1875	145	1105	0.58
15	1~	230	50	1785	192	0.97	62	70	76	1405	264	825	1.06
16	1~	230	50	1815	177	0.92	62	70	76	930	326	545	1.31

Wired = Wiring · U = Voltage · f = Frequency · n = Speed (rpm) · P_{ed} = Power consumption · I = Current draw · LpA_{in} = Sound pressure level intake side · LwA_{in} = Sound power level intake side · LwA_{out} = Sound power level outlet side · q_v = Air flow · p_{fs} = Pressure increase

