



R3G280-AF35-75 ebmpapst Datasheet

sales@fansco.com

www.fansco.com

Limited partnership · Headquarters Muldingen
 Amtsgericht (court of registration) Stuttgart · HRA 590344

General partner Elektrobau Muldingen GmbH · Headquarters Muldingen
 Amtsgericht (court of registration) Stuttgart · HRB 590142



Nominal data

Type	R3G280-AF35-75	
Motor	M3G084-DF	
Phase		1~
Nominal voltage	VAC	230
Nominal voltage range	VAC	200 .. 277
Frequency	Hz	50/60
Method of obtaining data		ml
Speed (rpm)	min ⁻¹	2600
Power consumption	W	455
Current draw	A	2.8
Min. ambient temperature	°C	-25
Max. ambient temperature	°C	40

ml = Max. load · me = Max. efficiency · fa = Free air · cs = Customer specification · ce = Customer equipment
 Subject to change

Data according to ErP Directive

		Actual	Req. 2015			
01 Overall efficiency η_{es}	%	49.2	48.2	09 Power consumption P_{ed}	kW	0.48
02 Measurement category		A		09 Air flow q_v	m ³ /h	1610
03 Efficiency category		Static		09 Pressure increase p_{fs}	Pa	484
04 Efficiency grade N		63	62	10 Speed (rpm) n	min ⁻¹	2595
05 Variable speed drive		Yes		11 Specific ratio*		1.01

Data obtained at optimum efficiency level.

The ErP data is determined using a motor-impeller combination in a standardized measurement setup.

* Specific ratio = $1 + p_{fs} / 100\,000\text{ Pa}$

LU-144378



Technical description

Weight	5.3 kg
Fan size	280 mm
Rotor surface	Painted black
Electronics housing material	Die-cast aluminum
Impeller material	Sheet steel, galvanized
Number of blades	11
Direction of rotation	Clockwise, viewed toward rotor
Degree of protection	IP54
Insulation class	"B"
Moisture (F) / Environmental (H) protection class	F3-1
Max. permitted ambient temp. for motor (transport/storage)	+80 °C
Min. permitted ambient temp. for motor (transport/storage)	-40 °C
Installation position	Any
Mode	S1
Motor bearing	Ball bearing
Technical features	<ul style="list-style-type: none"> - Output 10 VDC, max. 1.1 mA - Alarm relay - Motor current limitation - PFC, passive - Soft start - Control input 0-10 VDC / PWM - Control interface with SELV potential safely disconnected from the mains - Thermal overload protection for electronics/motor - Line undervoltage detection
Touch current according to IEC 60990 (measuring circuit Fig. 4, TN system)	<= 3.5 mA
Motor protection	Thermal overload protector (TOP) internally connected
With cable	Variable
Protection class	I (with customer connection of protective earth)
Conformity with standards	EN 61800-5-1; CE
Approval	CSA C22.2 No. 77; UL 2111; VDE

Product drawing

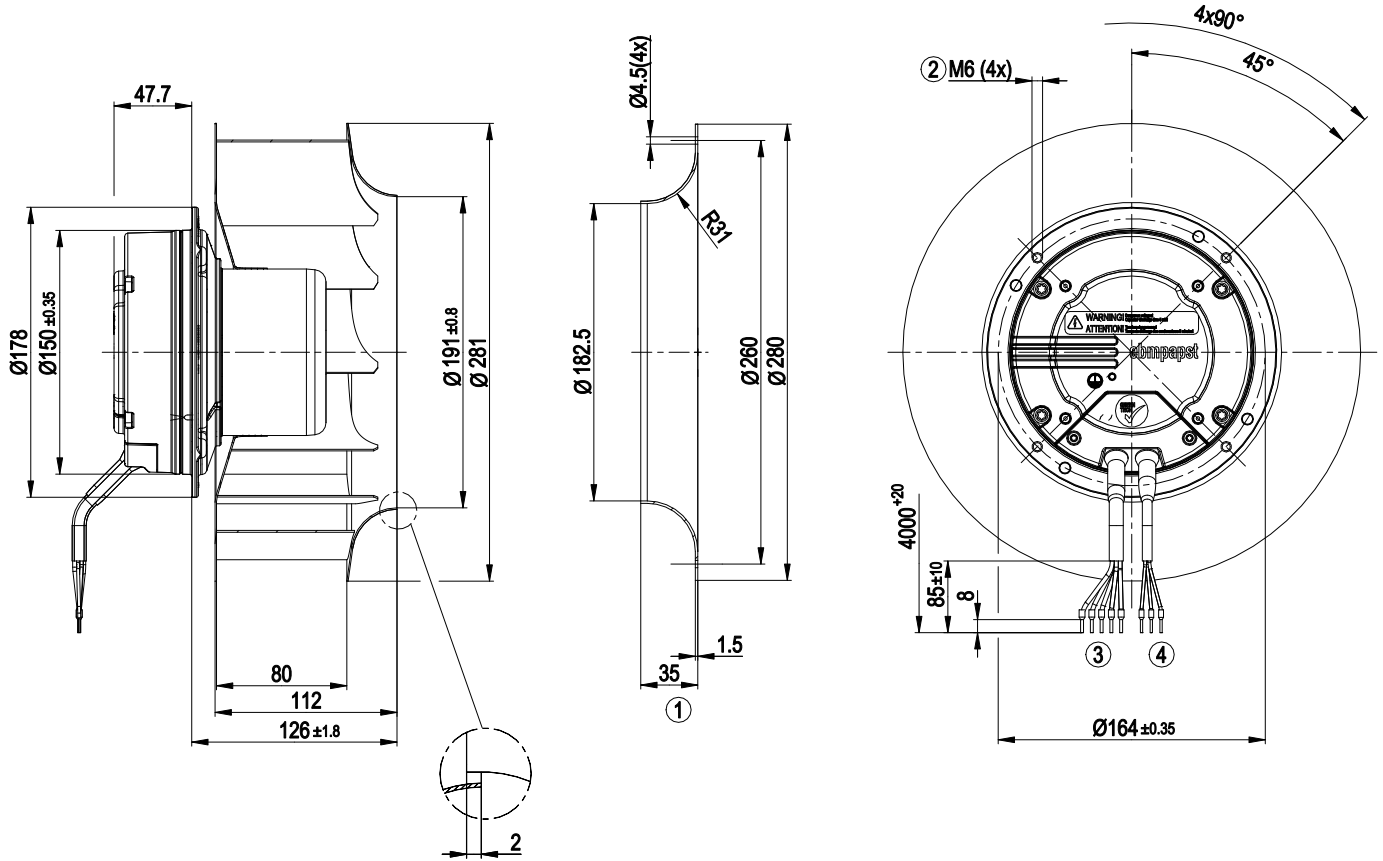

1	Accessory part: inlet ring 96360-2-4013 not included in scope of delivery
2	Max. clearance for screw 10 mm
3	Cable PVC AWG18, 5x crimped ferrules
4	Cable PVC AWG22, 3x crimped ferrules

Connection diagram

Customer circuit

Application notes for various control options

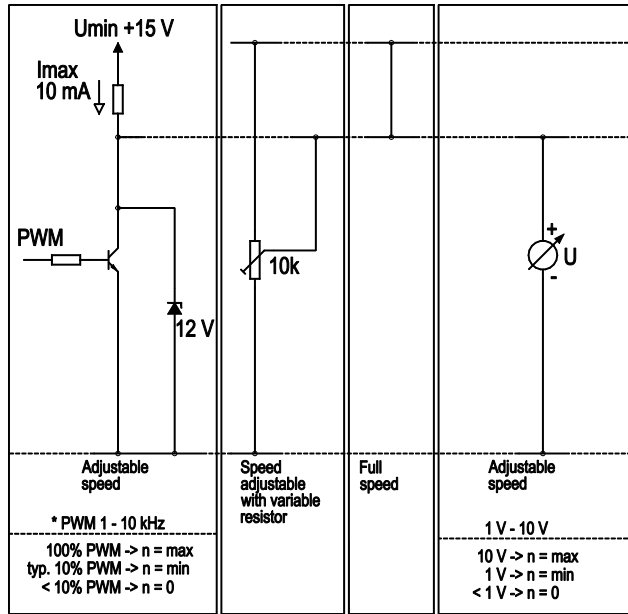

Connection

Fan / Motor

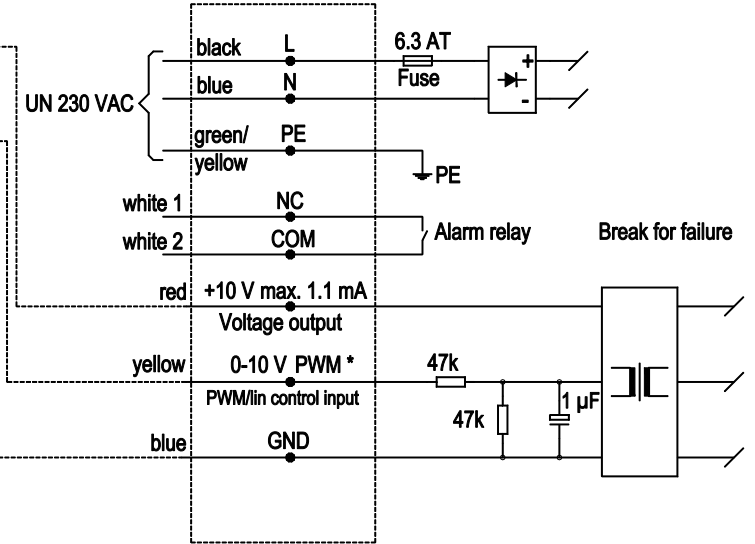

Curves: Air performance 50 Hz

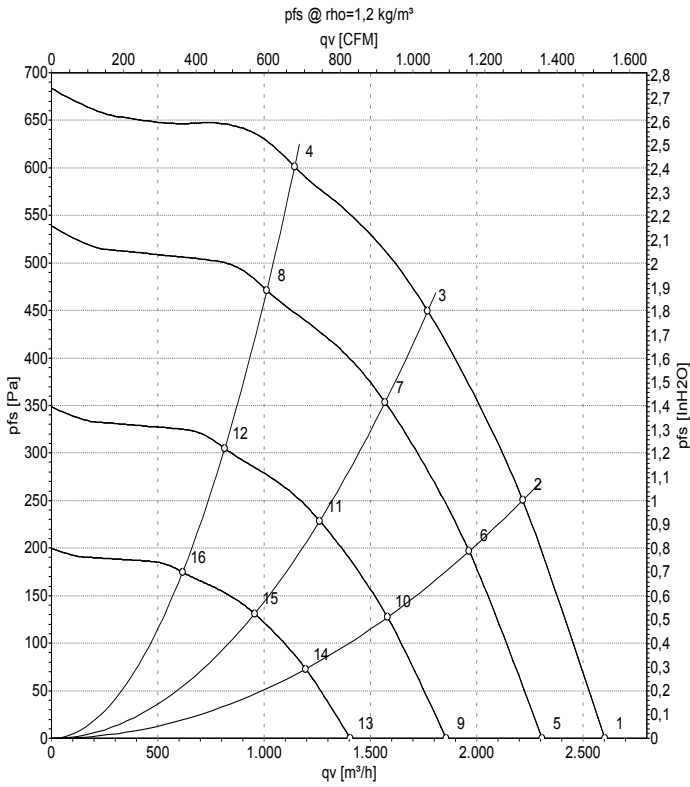

Measurement: LU-144378-1

Air performance measured according to ISO 5801 installation category A. For detailed information on the measurement setup, contact ebm-papst. Intake sound level: Sound power level according to ISO 13347 / sound pressure level measured at 1 m distance from fan axis. The values given are valid under the specified measuring conditions and may vary due to conditions of installation. For deviations from the standard configuration, the parameters have to be checked on the installed unit.

Measured values

	U	f	n	P _{ed}	I	LpA _{in}	LwA _{in}	qv	p _{fs}	qv	p _{fs}
	V	Hz	min ⁻¹	W	A	dB(A)	dB(A)	m ³ /h	Pa	CFM	inH ₂ O
1	230	50	2600	330	2.16	77	84	2605	0	1530	0.00
2	230	50	2600	430	2.78	74	82	2215	250	1305	1.00
3	230	50	2600	455	2.80	72	80	1770	450	1040	1.81
4	230	50	2600	422	2.78	73	81	1145	600	675	2.41
5	230	50	2300	230	1.51	74	81	2310	0	1360	0.00
6	230	50	2300	300	1.97	71	79	1965	199	1155	0.80
7	230	50	2300	338	2.24	69	77	1570	354	925	1.42
8	230	50	2300	293	1.94	70	78	1015	471	595	1.89
9	230	50	1850	120	0.78	68	76	1855	0	1095	0.00
10	230	50	1850	156	1.03	66	73	1580	129	930	0.52
11	230	50	1850	176	1.17	64	71	1260	229	745	0.92
12	230	50	1850	152	1.01	64	72	815	305	480	1.22
13	230	50	1400	52	0.34	61	69	1405	0	825	0.00
14	230	50	1400	68	0.44	58	66	1195	74	705	0.30
15	230	50	1400	76	0.51	57	64	955	131	560	0.53
16	230	50	1400	66	0.44	57	65	615	174	365	0.70

U = Power supply · f = Frequency · n = Speed (rpm) · P_{ed} = Power consumption · I = Current draw · LpA_{in} = Sound pressure level intake side · LwA_{in} = Sound power level intake side
 qv = Air flow · p_{fs} = Pressure increase

