

EC centrifugal fan

backward curved, single inlet

R3G280-AB56-13 ebmpapst Datasheet

sales@fansco.com

www.fansco.com

Limited partnership · Headquarters Muldingen
County court Stuttgart · HRA 590344

General partner Elektrobau Muldingen GmbH · Headquarters Muldingen
County court Stuttgart · HRB 590142

Nominal data

| | | |
|--------------------------|-----------------------|------------|
| Type | R3G280-AB56-13 | |
| Motor | M3G074-CF | |
| Phase | | 1~ |
| Nominal voltage | VAC | 230 |
| Nominal voltage range | VAC | 200 .. 277 |
| Frequency | Hz | 50/60 |
| Type of data definition | | ml |
| Speed | min ⁻¹ | 1700 |
| Power input | W | 95 |
| Current draw | A | 0.7 |
| Min. ambient temperature | °C | -25 |
| Max. ambient temperature | °C | 40 |

ml = max. load · me = max. efficiency · fa = running at free air · cs = customer specs · cu = customer unit
Subject to alterations



Technical features

| | |
|--|--|
| Mass | 3 kg |
| Size | 280 mm |
| Surface of rotor | Coated in black |
| Material of impeller | Sheet steel, hot-galvanised |
| Number of blades | 11 |
| Direction of rotation | Clockwise, seen on rotor |
| Type of protection | IP 44; Depending on installation and position as per EN 60034-5 |
| Insulation class | "B" |
| Humidity class | F3-1 |
| Max. permissible ambient motor temp. (transp./ storage) | + 80 °C |
| Min. permissible ambient motor temp. (transp./storage) | - 40 °C |
| Mounting position | Shaft horizontal or rotor on bottom; rotor on top on request |
| Condensate discharge holes | Rotor-side |
| Operation mode | S1 |
| Motor bearing | Ball bearing |
| Technical features | <ul style="list-style-type: none"> - Output 10 VDC, max. 1.1 mA - Tach output - Motor current limit - Soft start - Control input 0-10 VDC / PWM - Over-temperature protected electronics / motor |
| EMC interference immunity | Acc. to EN 61000-6-2 (industrial environment) |
| EMC harmonics | Acc. to EN 61000-3-2/3 |
| EMC interference emission | Acc. to EN 61000-6-3 (household environment) |
| Touch current acc. IEC 60990 (measuring network Fig. 4, TN system) | <= 3.5 mA |
| Motor protection | Thermal overload protector (TOP) wired internally |
| Cable exit | Variable |
| Protection class | I (if protective earth is connected by customer) |
| Product conforming to standard | EN 60335-1 |
| Approval | UL 2111; CSA C22.2 Nr.77 |

EC centrifugal fan

backward curved, single inlet

Product drawing

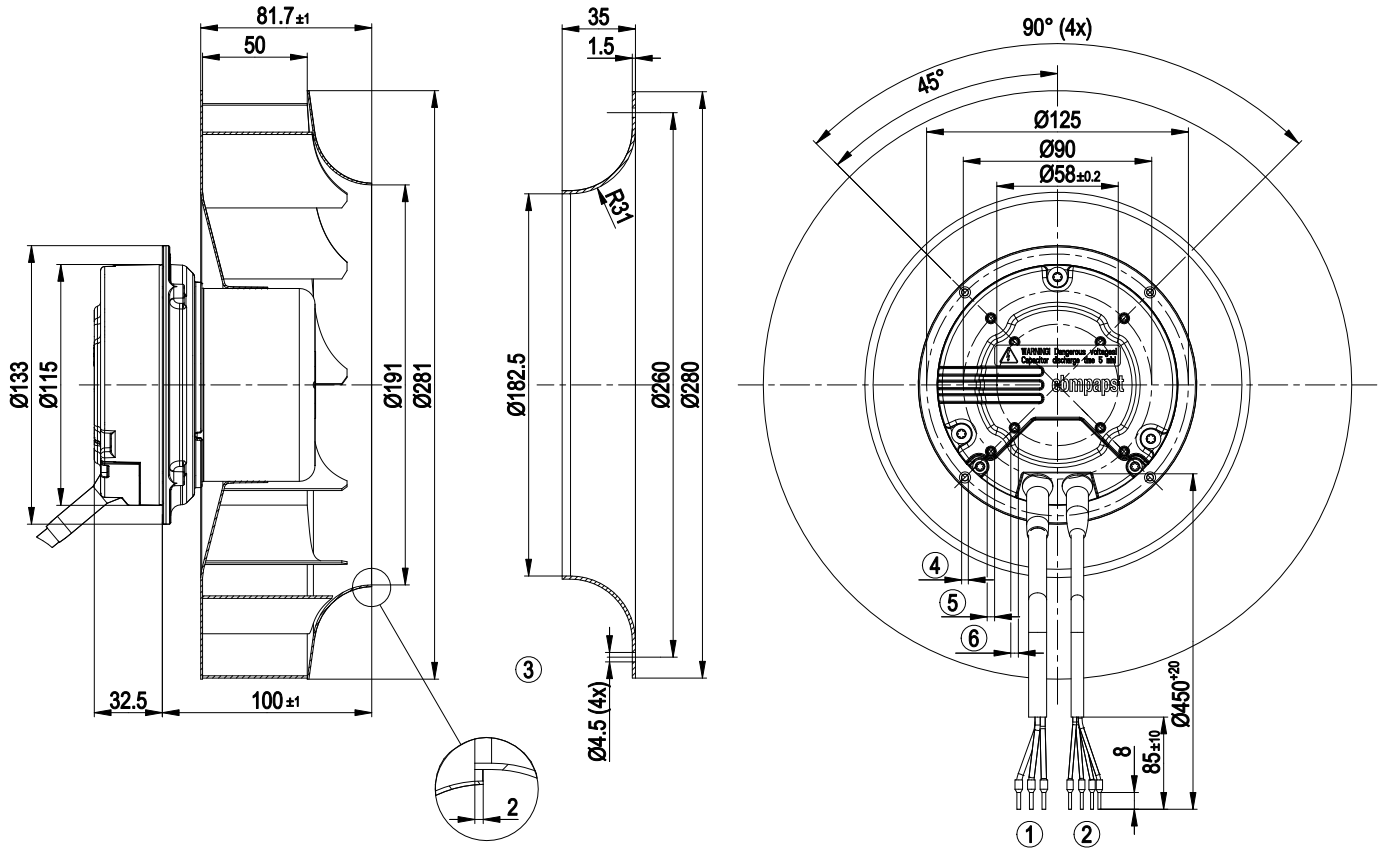

| | |
|---|--|
| 1 | Connection line AWG18, 3 x crimped core-end sleeves |
| 2 | Connection line AWG22, 4 x crimped core-end sleeves |
| 3 | Accessory part: inlet nozzle 96360-2-4013 not included in the standard scope of delivery; other inlet nozzles on request |
| 4 | Depth of screw 8 - 10 mm |
| 5 | Pilot hole prepared for self-tapping screw M4, depth of screw max. 6 mm |
| 6 | Pilot hole prepared for self-tapping screw M4, depth of screw max. 8 mm |



Connection screen

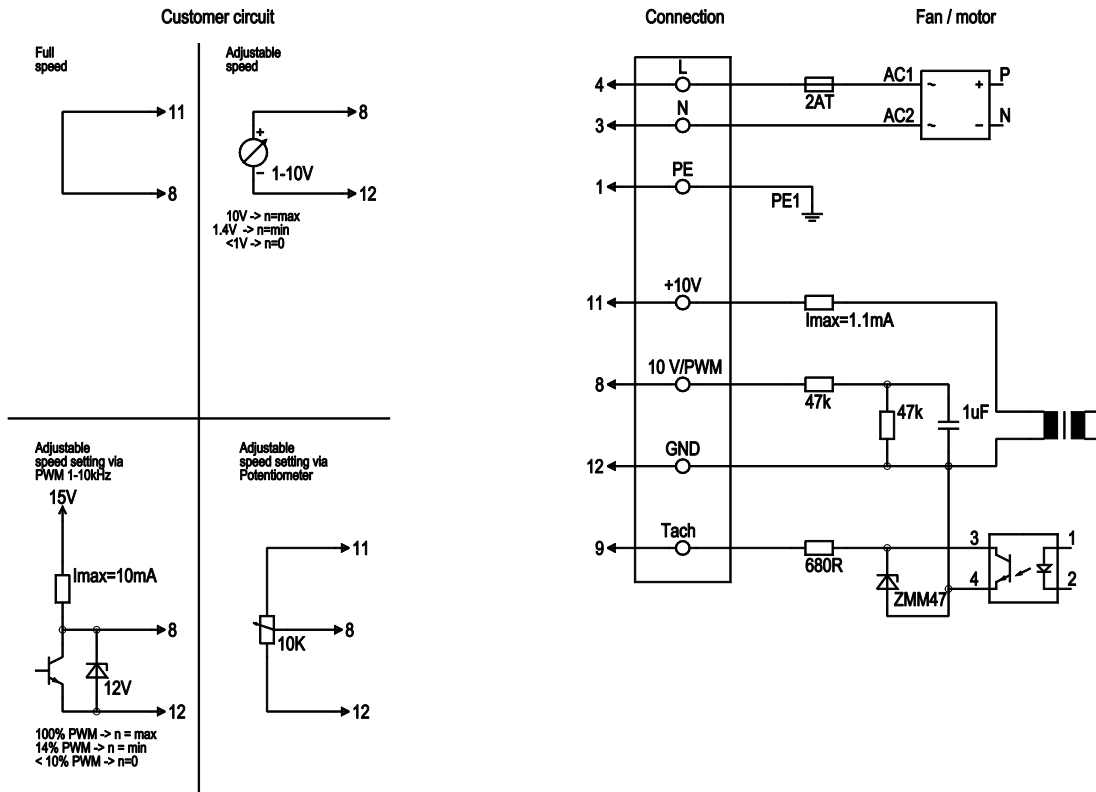

Not switchable with the supply voltage. Restart only after 5 minute delay via input voltage.

| Line | No. | Signal | Colour | Function / assignment |
|------|-----|------------------|--------------|--|
| | 4 | L | black | Power supply 230 VAC, 50-60 Hz, for voltage range refer to rating plate |
| | 3 | N | blue | Neutral conductor |
| | 1 | PE | green/yellow | Protective earth |
| | 8 | 0-10 V PWM | yellow | Control input 0 - 10 V or PWM, electrically isolated |
| | 9 | Tach | white | Tach output: open collector, 1 pulse per revolution, electrically isolated |
| | 11 | 10V / max 1.1 mA | red | Voltage output 10 V / max. 1.1 mA, electrically isolated |
| | 12 | GND | blue | GND - Connection for control interface |

Charts: Air flow 50 Hz

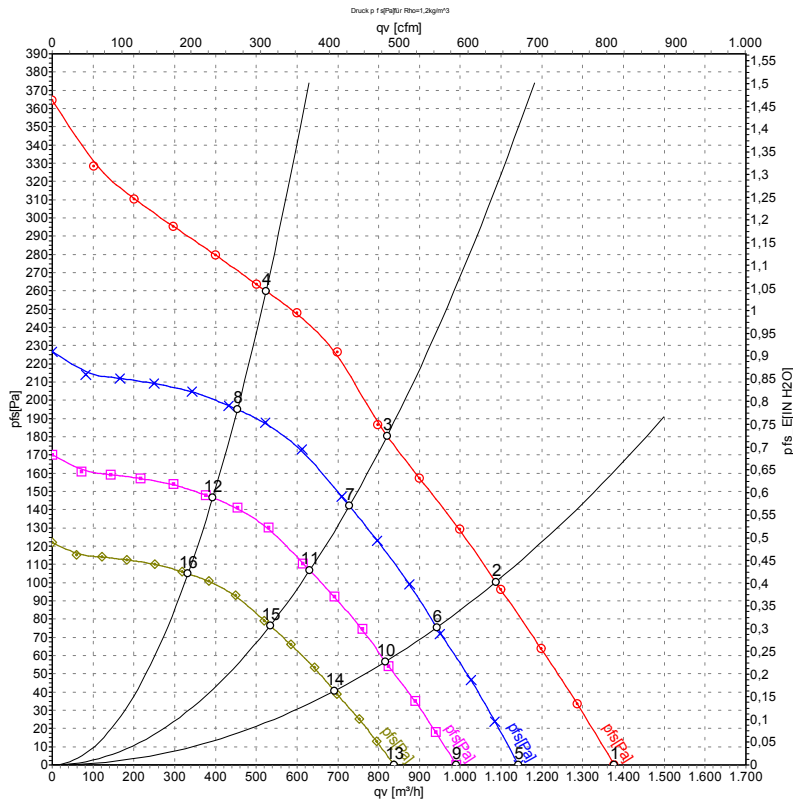

Measurement: LU-137130

Air performance measured as per ISO 5801 Installation category A. For detailed information on the measuring set-up, please contact ebmpapst. Suction-side noise levels: LwA measured as per ISO 13347 / LpA measured with 1m distance to fan axis. The values given are valid under the measuring conditions mentioned above and may vary according to the actual installation situation. With any deviation from the standard set-up, the specific values have to be checked and reviewed with the unit installed.

Measured values

| | U | f | n | P _{ed} | I | qv | P _{fs} |
|----|-----|----|-------------------|-----------------|------|-------------------|-----------------|
| | V | Hz | min ⁻¹ | W | A | m ³ /h | Pa |
| 1 | 230 | 50 | 1810 | 68 | 0.49 | 1375 | 0 |
| 2 | 230 | 50 | 1730 | 86 | 0.61 | 1085 | 100 |
| 3 | 230 | 50 | 1700 | 95 | 0.70 | 820 | 180 |
| 4 | 230 | 50 | 1730 | 87 | 0.62 | 525 | 260 |
| 5 | 230 | 50 | 1500 | 39 | 0.28 | 1145 | 0 |
| 6 | 230 | 50 | 1500 | 56 | 0.40 | 940 | 75 |
| 7 | 230 | 50 | 1500 | 65 | 0.46 | 730 | 142 |
| 8 | 230 | 50 | 1500 | 57 | 0.40 | 455 | 195 |
| 9 | 230 | 50 | 1300 | 25 | 0.18 | 990 | 0 |
| 10 | 230 | 50 | 1300 | 37 | 0.26 | 815 | 56 |
| 11 | 230 | 50 | 1300 | 43 | 0.30 | 630 | 107 |
| 12 | 230 | 50 | 1300 | 37 | 0.26 | 395 | 146 |
| 13 | 230 | 50 | 1100 | 15 | 0.11 | 840 | 0 |
| 14 | 230 | 50 | 1100 | 22 | 0.16 | 690 | 40 |
| 15 | 230 | 50 | 1100 | 26 | 0.18 | 535 | 76 |
| 16 | 230 | 50 | 1100 | 22 | 0.16 | 335 | 105 |

U = Supply voltage · f = Frequency · n = Speed · P_{ed} = Power input · I = Current draw · qv = Air flow · p_{fs} = Pressure increase

