

R3G250-RU27-88 ebmpapst Datasheet

sales@fansco.com

www.fansco.com

Limited partnership · Headquarters Mulfingen

Amtsgericht (court of registration) Stuttgart · HRA 590344

General partner Elektrobau Mulfingen GmbH · Headquarters Mulfingen

Amtsgericht (court of registration) Stuttgart · HRB 590142

## Nominal data

Type	R3G250-RU27-88	
Motor	M3G084-CF	
Nominal voltage	VDC	26
Nominal voltage range	VDC	16 .. 32
Method of obtaining data		fa
Speed (rpm)	min <sup>-1</sup>	3860
Power consumption	W	410
Current draw	A	15.8
Min. ambient temperature	°C	-40
Max. ambient temperature	°C	60

ml = Max. load · me = Max. efficiency · fa = Free air · cs = Customer specification · ce = Customer equipment  
Subject to change

## Data according to Commission Regulation (EU) 327/2011 (EN 17166)

		Actual	Req. 2015			
01 Overall efficiency $\eta_{es}$	%	57.6	48.9	09 Power consumption $P_e$	kW	0.56
02 Measurement category		A		09 Air flow $q_v$	m <sup>3</sup> /h	1345
03 Efficiency category		Static		09 Pressure increase $p_{fs}$	Pa	789
04 Efficiency grade N		70.7	62	10 Speed (rpm) n	min <sup>-1</sup>	3845
05 Variable speed drive		Yes		11 Specific ratio*		1.01

Data obtained at optimum efficiency level.

The ErP data is determined using a motor-impeller combination in a standardized measurement setup.

\* Specific ratio =  $1 + p_{fs} / 100\,000\text{ Pa}$ 

LU-162027



### Technical description

<b>Weight</b>	2.75 kg
<b>Size</b>	250 mm
<b>Motor size</b>	84
<b>Rotor surface</b>	Painted black
<b>Electronics housing material</b>	Die-cast aluminum, painted black
<b>Impeller material</b>	PA plastic, sheet-metal plate painted black
<b>Number of blades</b>	7
<b>Direction of rotation</b>	Clockwise, viewed toward rotor
<b>Degree of protection</b>	Motor IP24 KM, electronics IP6K9K (mating connector installed)
<b>Insulation class</b>	"B"
<b>Moisture (F) / Environmental (H) protection class</b>	H3
<b>Max. permitted ambient temp. for motor (transport/storage)</b>	+80 °C
<b>Min. permitted ambient temp. for motor (transport/storage)</b>	-40 °C
<b>Installation position</b>	Shaft horizontal or rotor on bottom; rotor on top on request
<b>Cooling hole/opening</b>	On rotor side
<b>Mode</b>	S1
<b>Motor bearing</b>	Ball bearing made of stainless steel; (sealed)
<b>Technical features</b>	<ul style="list-style-type: none"> <li>- Error output (high-side switch)</li> <li>- Load dump (58 V)</li> <li>- Motor current limitation</li> <li>- Soft start</li> <li>- Control input 0-10 VDC / PWM</li> <li>- Temperature derating</li> <li>- Overvoltage detection</li> <li>- Thermal overload protection for electronics</li> <li>- Line undervoltage detection</li> </ul>
<b>EMC regulations</b>	According to EN 50121-3-2
<b>Electrical hookup</b>	Standby current less than 500 µA
<b>With cable</b>	Lateral
<b>Protection class</b>	III
<b>Conformity with standards</b>	EN 15085-1, CPC3: 2007; EN 45545-2, HL3: 2013; EN 50155: 2008; EN 61373, Cat. 1B: 2010; CE
<b>Approval</b>	EAC

# EC centrifugal fan - RadiCal

backward-curved, single-intake  
for rail applications

## Product drawing

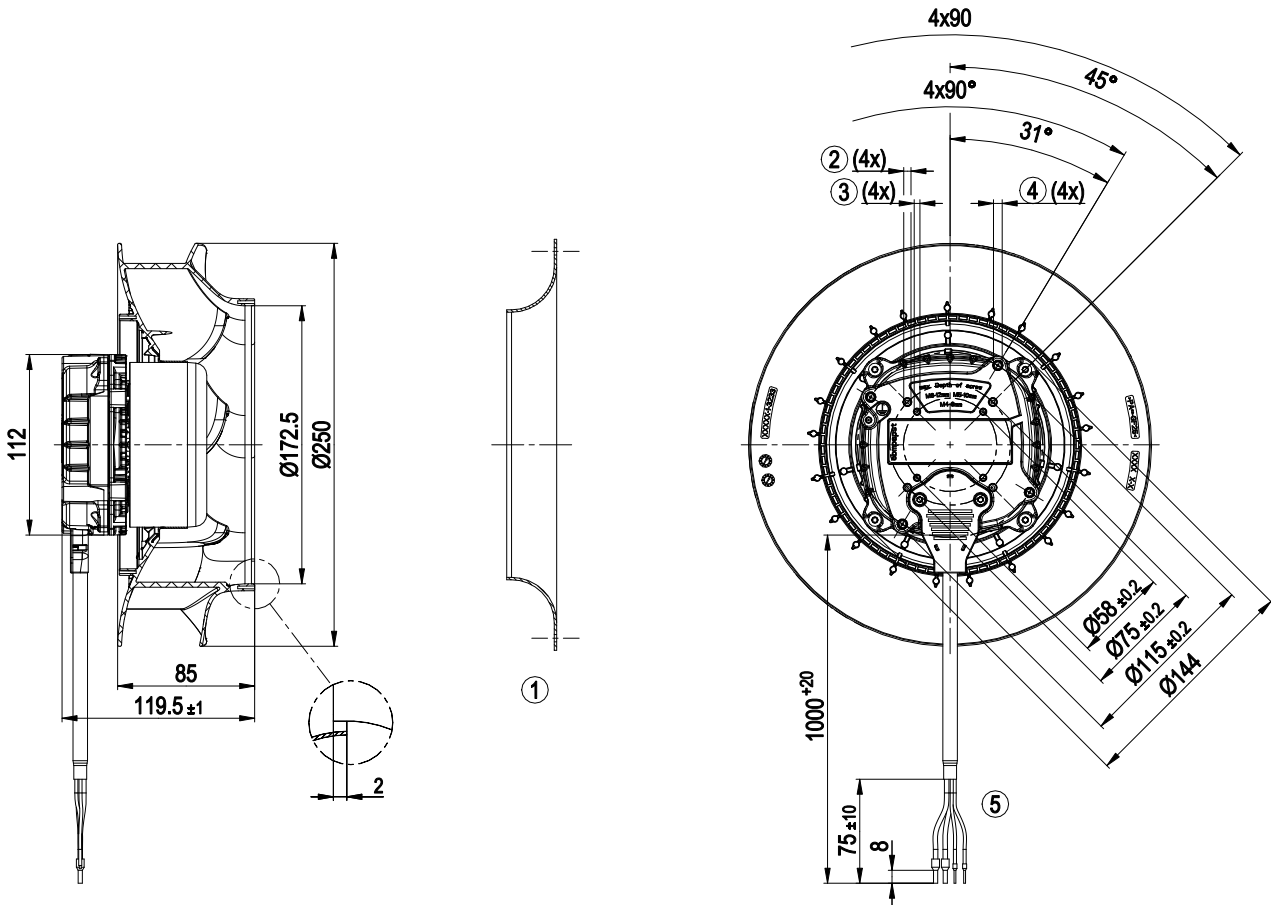

1	Accessory part: inlet ring 96359-2-4013 not included in scope of delivery
2	Tapping hole prepared for self-tapping M5 screw, max. screw-in depth 10 mm
3	Tapping hole prepared for self-tapping M4 screw, max. screw-in depth 8 mm
4	Tapping hole prepared for self-tapping M6 screw, max. screw-in depth 12 mm
5	Cable, halogen-free, railway application EN 45545, 2x 2.5 mm <sup>2</sup> , 2x 1.0 mm <sup>2</sup>
	4x wire-end ferrule



# EC centrifugal fan - RadiCal

backward-curved, single-intake

for rail applications

## Accessory part

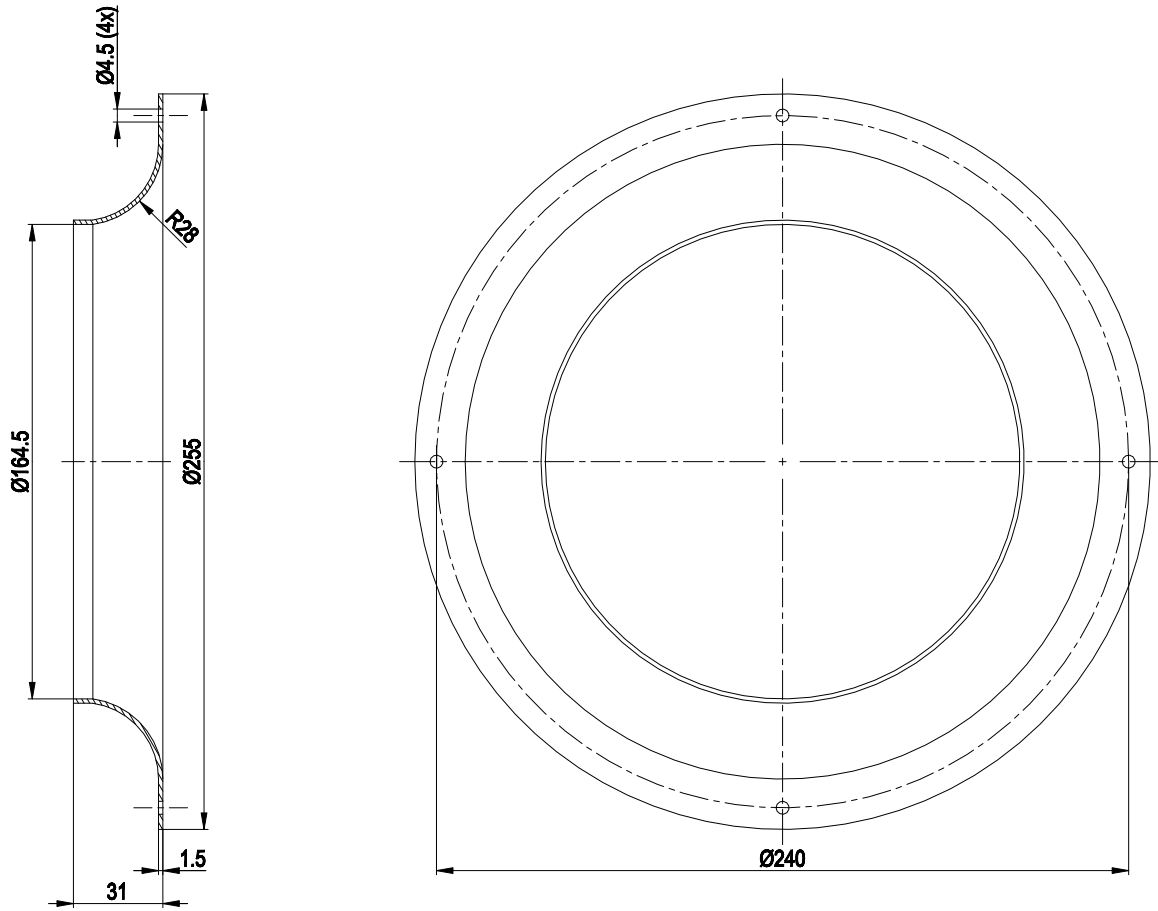

Inlet ring 96359-2-4013



# EC centrifugal fan - RadiCal

backward-curved, single-intake

for rail applications

## Connection diagram

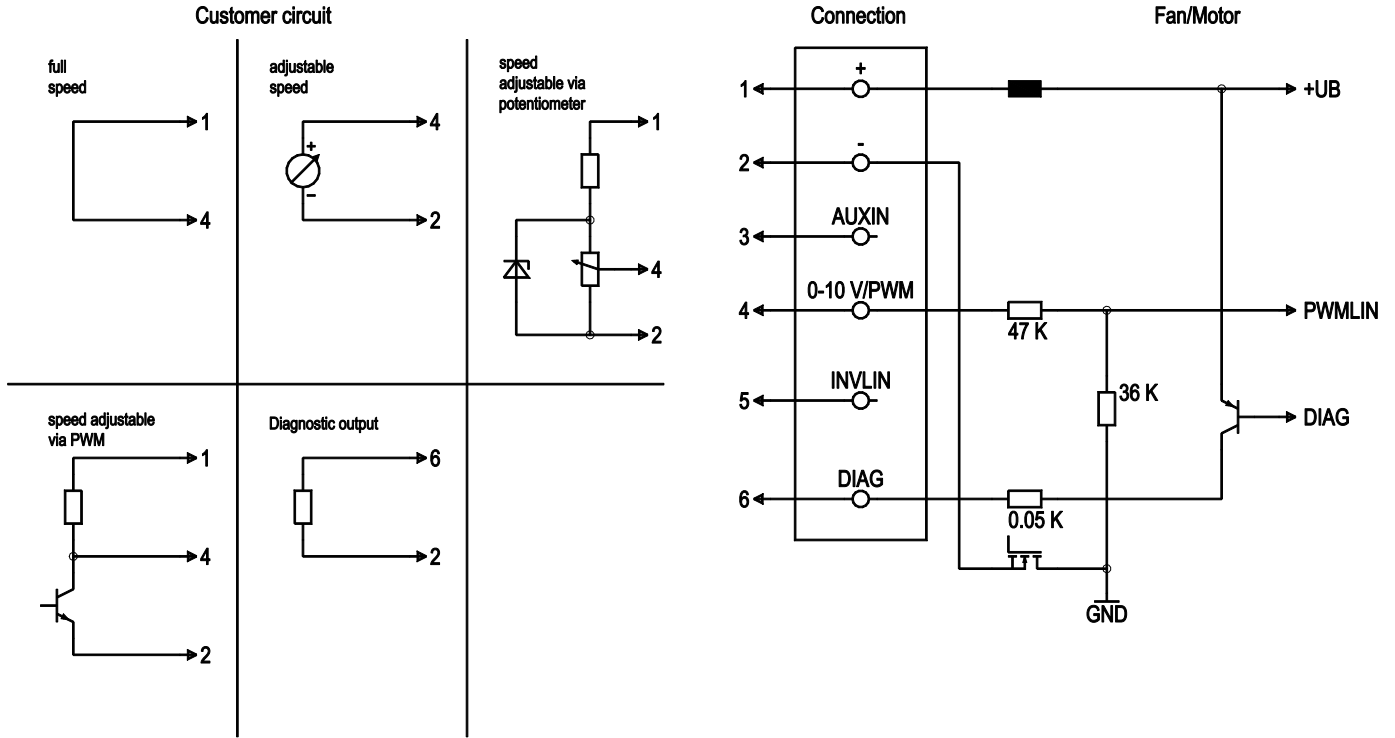

No.	Conn.	Designation	Color	Function/assignment
	1	+	black	Power supply, see nameplate for voltage range
	2	-	brown	Power supply, see nameplate for voltage range
	3	AUXIN		not used
	4	0-10 V / PWM	yellow	Control input: $R_i > 47\text{ k}\Omega$ 0-10 V (typ. $< 1\text{ V} \rightarrow n=0$ ; $1.5\text{ V} \rightarrow n=\text{min}$ ; $> 10\text{ V} \rightarrow n=\text{max}$ ) PWM (amplitude 10 V; 1-50 kHz; typ. $< 5\% \rightarrow n=0$ ; $15\% \rightarrow n=\text{min}$ ; $> 100\% \rightarrow n=\text{max}$ )
	5	INVLIN		not used
	6	DIAG	white	Diagnostic output: Open collector, $I_{\text{source max}} = 20\text{ mA}$ , Fan OK $\rightarrow$ low; fan error $\rightarrow$ high



## Curves: Air performance

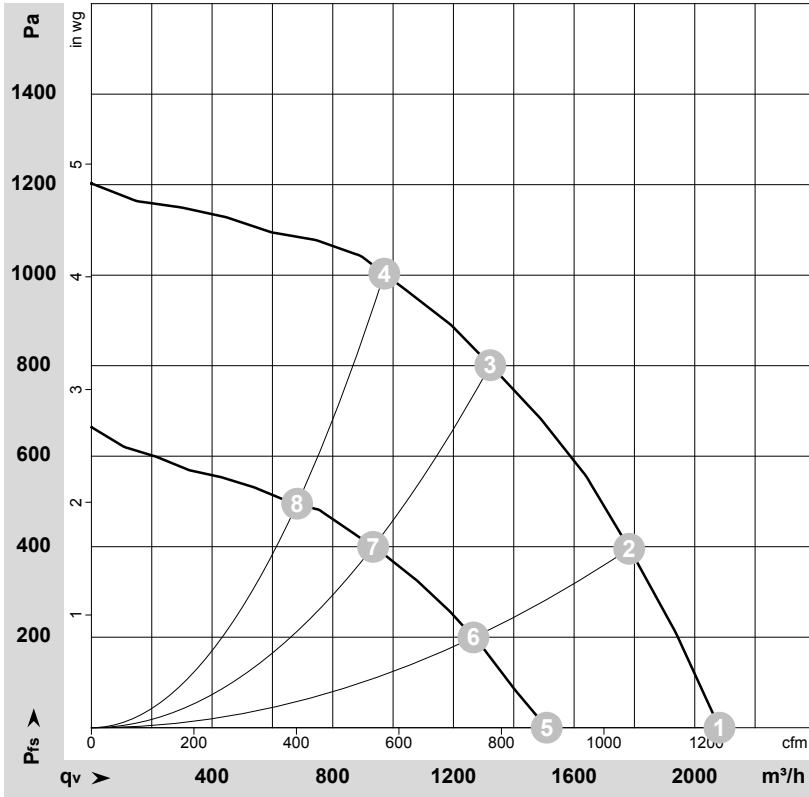

$\rho = 1.15 \text{ kg/m}^3 \pm 2 \%$

Measurement: LU-162027-1  
Measurement: LU-162195-1

Air performance measured according to ISO 5801 installation category A. For detailed information on the measurement setup, contact ebmpapst. Intake sound level: Sound power level according to ISO 13347 / sound pressure level measured at 1 m distance from fan axis. The values given are valid under the specified measuring conditions and may vary due to conditions of installation. For deviations from the standard configuration, the parameters have to be checked on the installed unit.

## Measured values

	U	n	P <sub>ed</sub>	I	LpA <sub>in</sub>	LwA <sub>in</sub>	q <sub>v</sub>	P <sub>fs</sub>	q <sub>v</sub>	P <sub>fs</sub>
	V	min <sup>-1</sup>	W	A	dB(A)	dB(A)	m <sup>3</sup> /h	Pa	cfm	in. wg
1	26-32	3860	410	15.80*	80	87	2080	0	1225	0.00
2	26-32	3860	513	19.80*	78	85	1785	400	1050	1.61
3	26-32	3860	568	21.90*	74	81	1320	800	780	3.21
4	26-32	3860	560	21.60*	76	82	970	1000	570	4.01
5	16	2800	166	10.43			1510	0	890	0.00
6	16	2755	187	11.72			1265	200	745	0.80
7	16	2730	204	12.78			935	400	550	1.61
8	16	2730	197	12.39			680	495	400	1.99

U = Voltage · n = Speed (rpm) · P<sub>ed</sub> = Power consumption · I = Current draw · \* = Current measured at nominal voltage · LpA<sub>in</sub> = Sound pressure level intake side · LwA<sub>in</sub> = Sound power level intake side  
q<sub>v</sub> = Air flow · P<sub>fs</sub> = Pressure increase

