

R3G250-RR01-H8 ebmpapst Datasheet

sales@fansco.com

www.fansco.com

Limited partnership · Headquarters Mulfingen

Amtsgericht (court of registration) Stuttgart · HRA 590344

General partner Elektrobau Mulfingen GmbH · Headquarters Mulfingen

Amtsgericht (court of registration) Stuttgart · HRB 590142

Nominal data

Type	R3G250-RR01-H8	
Motor	M3G084-DF	
Phase		1~
Nominal voltage	VAC	230
Nominal voltage range	VAC	200 .. 277
Frequency	Hz	50/60
Method of obtaining data		ml
Speed (rpm)	min ⁻¹	3740
Power consumption	W	500
Current draw	A	2.2
Min. ambient temperature	°C	-25
Max. ambient temperature	°C	60

ml = Max. load · me = Max. efficiency · fa = Free air · cs = Customer specification · ce = Customer equipment
Subject to change

Data according to Commission Regulation (EU) 327/2011

		Actual	Req. 2015			
01 Overall efficiency η_{es}	%	60.1	48.3	09 Power consumption P_{ed}	kW	0.5
02 Measurement category		A		09 Air flow q_v	m ³ /h	1355
03 Efficiency category		Static		09 Pressure increase p_{fs}	Pa	733
04 Efficiency grade N		73.8	62	10 Speed (rpm) n	min ⁻¹	3735
05 Variable speed drive		Yes		11 Specific ratio*		1.01

Data obtained at optimum efficiency level.

The ErP data is determined using a motor-impeller combination in a standardized measurement setup.

* Specific ratio = $1 + p_{fs} / 100\,000\text{ Pa}$

LU-151690



Technical description

Weight	4.1 kg
Size	250 mm
Motor size	84
Rotor surface	Painted black
Electronics housing material	Die-cast aluminum
Impeller material	PA plastic
Number of blades	7
Direction of rotation	Clockwise, viewed toward rotor
Degree of protection	Motor IP55, electronics IP20
Insulation class	"F"
Moisture (F) / Environmental (H) protection class	H0 - dry environment
Max. permitted ambient temp. for motor (transport/storage)	+80 °C
Min. permitted ambient temp. for motor (transport/storage)	-40 °C
Installation position	Shaft horizontal or rotor on bottom; rotor on top on request
Condensation drainage holes	On rotor side
Mode	S1
Motor mounting	Ball bearing
Technical features	<ul style="list-style-type: none"> - Output 10 VDC, max. 10 mA - Operation and alarm display with LED - Alarm relay - Integrated PID controller - Power limiter - Motor current limitation - PFC, active - RS-485 MODBUS-RTU - Soft start - Control input 0-10 VDC / PWM - Control interface with SELV potential safely disconnected from the mains - Thermal overload protection for electronics/motor - Line undervoltage / phase failure detection
EMC immunity to interference	According to EN 61000-6-2 (industrial environment)
EMC circuit feedback	According to EN 61000-3-2/3
EMC interference emission	According to EN 61000-6-3 (household environment)
Touch current according to IEC 60990 (measuring circuit Fig. 4, TN system)	<= 3.5 mA
Electrical hookup	Plug
Motor protection	Thermal overload protector (TOP) internally connected
With cable	Variable
Protection class	I (with customer connection of protective earth)
Conformity with standards	EN 61800-5-1; CE
Approval	CSA C22.2 No. 77 + CAN/CSA-E60730-1; UL 1004-7 + 60730

Product drawing

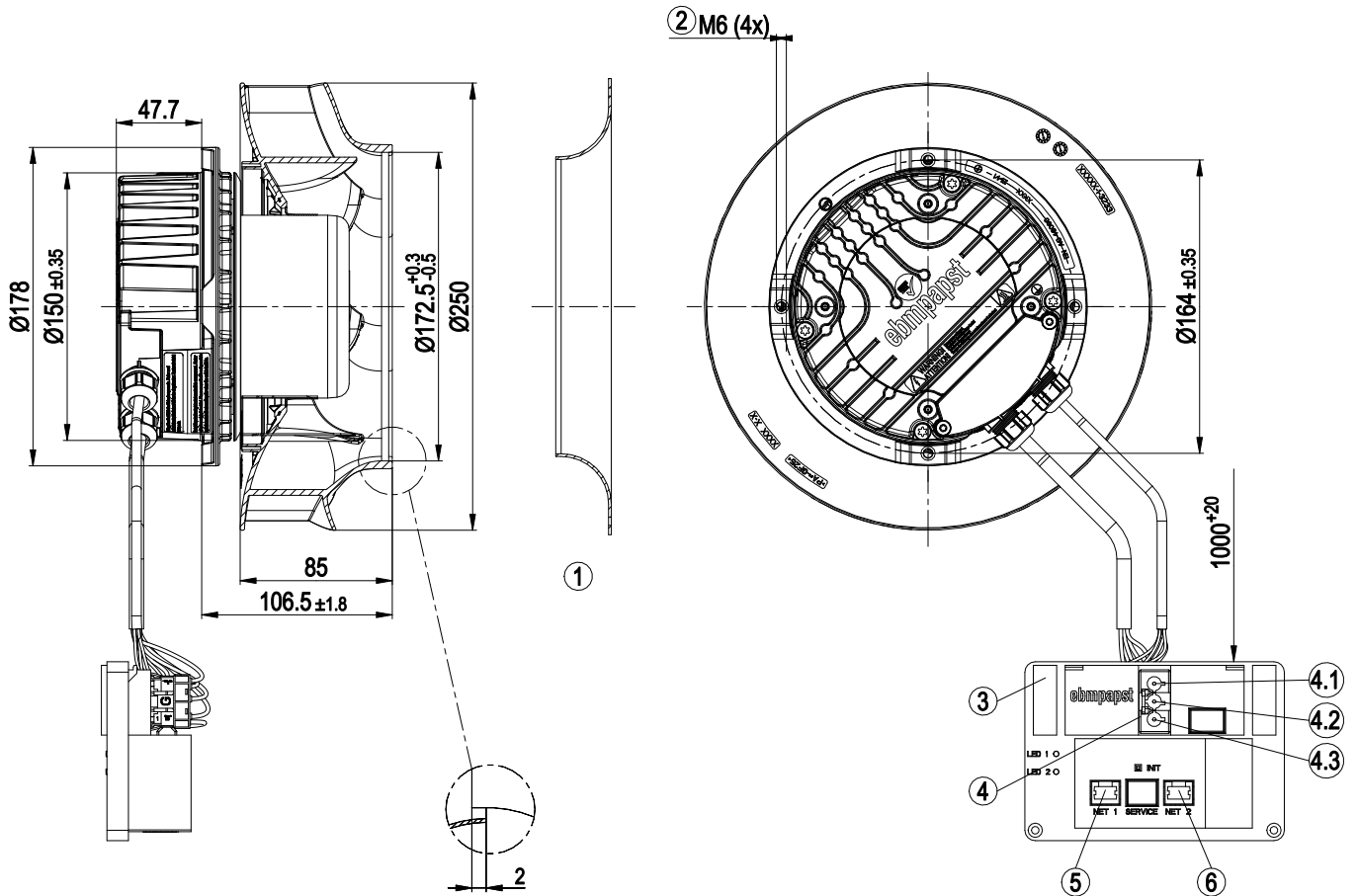

1	Accessory part: inlet ring 96359-2-4013 not included in scope of delivery
2	Max. clearance for screw 16 mm
3	Terminal box
4	Connector housing 3-pole GST18/3 Wieland 92.032.9058.1
4.1	N
4.2	PE
4.3	L
5	8-pole connector housing TE 100616-2
6	8-pole connector housing TE 100616-2

Accessory part

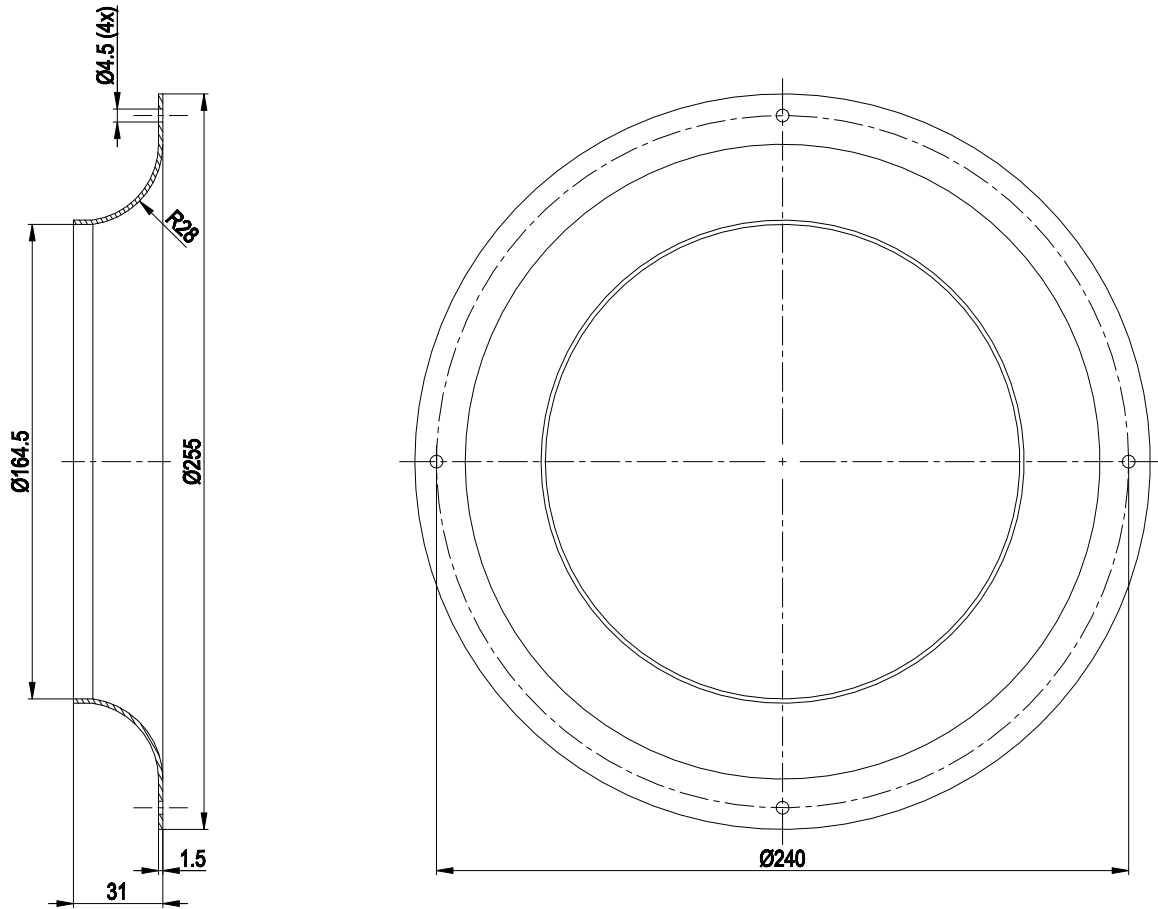

Accessory part: inlet ring 96359-2-4013 not included in scope of delivery



Connection diagram

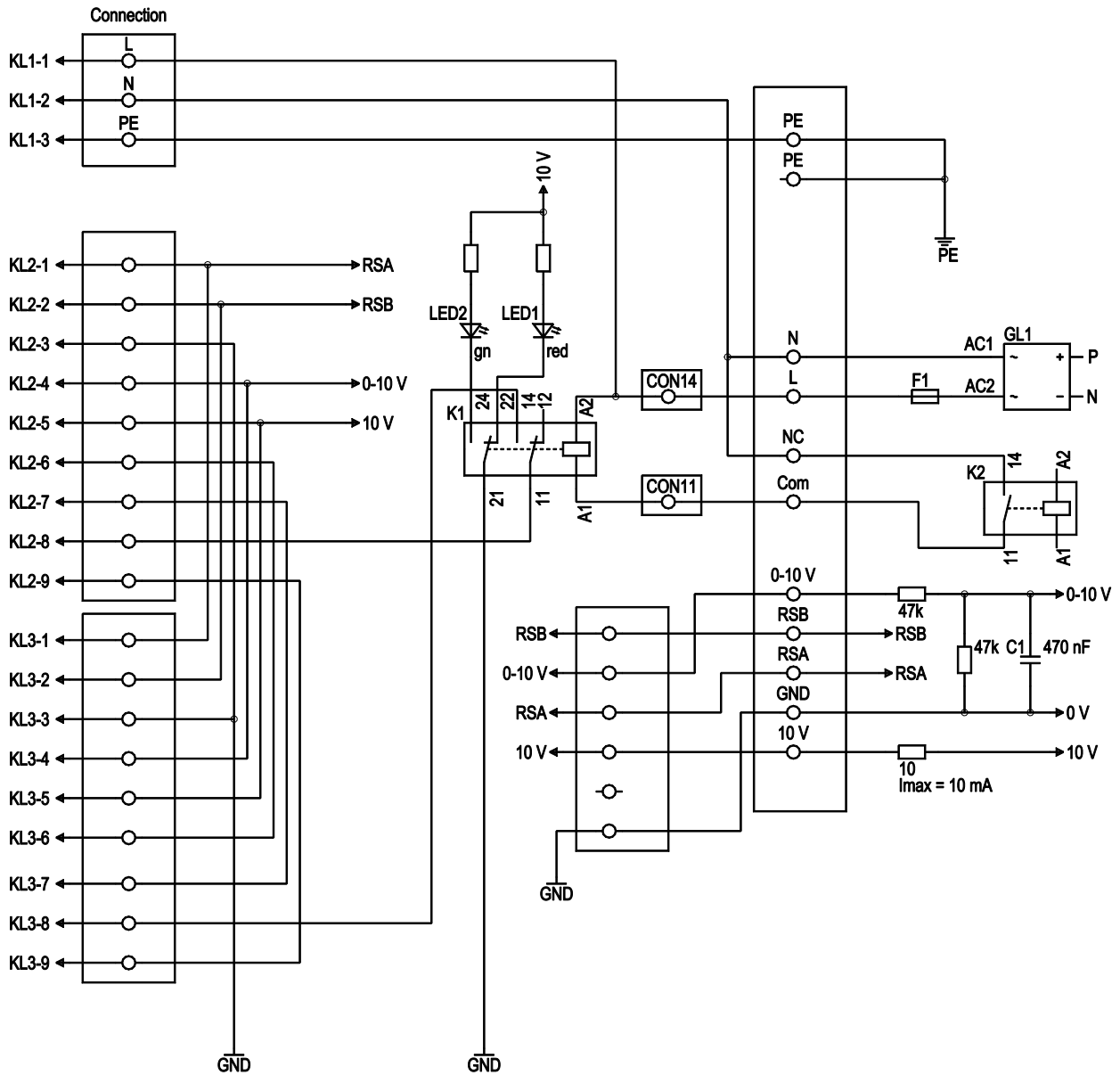

No.	Conn.	Designation	Color	Function/assignment
1	1	L	black	Supply connection, power supply single-phase 200-277 VAC, 50/60 Hz
1	2	N	blue	Power supply, single-phase 200-277 VAC, 50/60 Hz
1	3	PE	green/yellow	Ground connection
2	1	RSA	-	Bus connection RS485, RSA, MODBUS-RTU; SELV
2	2	RSB	-	Bus connection RS485, RSB, MODBUS-RTU; SELV
2	3	GND	-	Reference ground for control interface; SELV
2	4	0-10 V	-	Control input
2	5	+10 V	-	Fixed voltage output 10 VDC
2	6	RES	-	Reserve
2	7	COM*	-	Alarm COM*
2	8	NC	-	NC KL2 UMAX 24 V
2	9	Schirm	-	Shield



EC centrifugal fan

backward-curved, single-intake

No.	Conn.	Designation	Color	Function/assignment
3	1	RSA	-	Bus connection RS485, RSA, MODBUS-RTU; SELV
3	2	RSB	-	Bus connection RS485, RSB, MODBUS-RTU; SELV
3	3	GND	-	Reference ground for interface; SELV
3	4	0-10 V	-	Control input
3	5	+10 V	-	Fixed voltage output 10 VDC
3	6	RES	-	Reserve
3	7	COM*	-	Alarm COM*
3	8	NC*	-	NC* KL3 UMAX 24 V
3	9	Schirm	-	Shield



Curves: Air performance 50 Hz

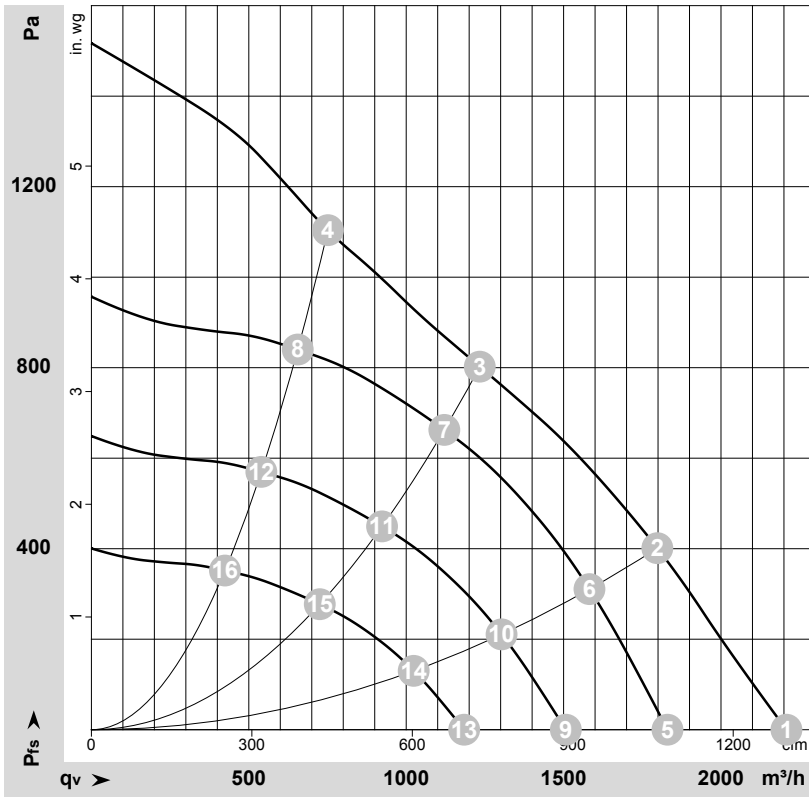

$\rho = 1.15 \text{ kg/m}^3 \pm 2 \%$

Measurement: LU-151690-1

Air performance measured according to ISO 5801 installation category A. For detailed information on the measurement setup, contact ebmpapst. Intake sound level: Sound power level according to ISO 13347 / sound pressure level measured at 1 m distance from fan axis. The values given are valid under the specified measuring conditions and may vary due to conditions of installation. For deviations from the standard configuration, the parameters have to be checked on the installed unit.

Measured values

	U	f	n	P _{ed}	I	LpA _{in}	LwA _{in}	q _v	P _{fs}	q _v	P _{fs}
	V	Hz	min ⁻¹	W	A	dB(A)	dB(A)	m ³ /h	Pa	cfm	in. wg
1	230	50	4100	500	2.20	81	89	2210	0	1300	0.00
2	230	50	3865	500	2.20	75	83	1800	400	1060	1.61
3	230	50	3740	500	2.20	70	78	1235	800	725	3.21
4	230	50	3890	500	2.20	78	85	750	1100	440	4.42
5	230	50	3400	292	1.27	76	84	1830	0	1075	0.00
6	230	50	3400	347	1.51	72	80	1580	311	930	1.25
7	230	50	3400	383	1.67	67	75	1120	663	660	2.66
8	230	50	3400	341	1.49	75	81	655	841	385	3.38
9	230	50	2800	163	0.71	71	79	1505	0	885	0.00
10	230	50	2800	194	0.85	67	75	1305	211	765	0.85
11	230	50	2800	214	0.93	63	70	925	450	545	1.81
12	230	50	2800	190	0.83	70	77	540	570	320	2.29
13	230	50	2200	79	0.35	65	73	1185	0	695	0.00
14	230	50	2200	94	0.41	61	69	1025	130	605	0.52
15	230	50	2200	104	0.45	56	64	725	278	425	1.12
16	230	50	2200	92	0.40	64	70	425	352	250	1.41

U = Power supply · f = Frequency · n = Speed (rpm) · P_{ed} = Power consumption · I = Current draw · LpA_{in} = Sound pressure level intake side · LwA_{in} = Sound power level intake side
 q_v = Air flow · P_{fs} = Pressure increase

