

R3G250-RP48-B3 ebmpapst Datasheet
 sales@fansco.com
 www.fansco.com

Limited partnership · Headquarters Muldingen
 Amtsgericht (court of registration) Stuttgart · HRA 590344
 General partner Elektrobau Muldingen GmbH · Headquarters Muldingen
 Amtsgericht (court of registration) Stuttgart · HRB 590142

Nominal data

Type	R3G250-RP48-B3	
Motor	M3G084-FA	
Phase		1~
Nominal voltage	VAC	230
Nominal voltage range	VAC	200 .. 277
Frequency	Hz	50/60
Method of obtaining data		ml
Speed (rpm)	min ⁻¹	4200
Power consumption	W	750
Current draw	A	3.3
Min. ambient temperature	°C	-25
Max. ambient temperature	°C	60

ml = Max. load · me = Max. efficiency · fa = Free air · cs = Customer specification · ce = Customer equipment
 Subject to change

Data according to Commission Regulation (EU) 327/2011 (EN 17166)

		Actual	Req. 2015			
01 Overall efficiency η_{es}	%	57.7	50.2	09 Power consumption P_{ed}	kW	0.74
02 Measurement category		A		09 Air flow q_v	m ³ /h	1405
03 Efficiency category		Static		09 Pressure increase p_{fs}	Pa	1005
04 Efficiency grade N		69.5	62	10 Speed (rpm) n	min ⁻¹	4215
05 Variable speed drive		Yes		11 Specific ratio*		1.01

Data obtained at optimum efficiency level.

The ErP data is determined using a motor-impeller combination in a standardized measurement setup.

* Specific ratio = $1 + p_{fs} / 100\,000\text{ Pa}$

LU-139950



Technical description

Weight	5 kg
Size	250 mm
Motor size	84
Rotor surface	Painted black
Electronics housing material	Die-cast aluminum
Impeller material	PA plastic
Number of blades	7
Direction of rotation	Clockwise, viewed toward rotor
Degree of protection	IP54
Insulation class	"B"
Moisture (F) / Environmental (H) protection class	H1
Max. permitted ambient temp. for motor (transport/storage)	+80 °C
Min. permitted ambient temp. for motor (transport/storage)	-40 °C
Installation position	Shaft horizontal or rotor on top; rotor on bottom on request
Condensation drainage holes	None
Mode	S1
Motor bearing	Ball bearing
Technical features	<ul style="list-style-type: none"> - Output 10 VDC, max. 10 mA - Output 20 VDC, max. 50 mA - Output for slave 0-10 V - Selection of direction of rotation left/right - Input for sensor 0-10 V or 4-20 mA - Alarm relay - Power limit - Motor current limitation - PFC, active - RS-485 MODBUS-RTU - Soft start - Control input 0-10 VDC / PWM - Control interface with SELV potential safely disconnected from supply - Thermal overload protection for electronics/motor - Line undervoltage / phase failure detection
Touch current according to IEC 60990 (measuring circuit Fig. 4, TN system)	<= 3.5 mA
Electrical hookup	Terminal box
Motor protection	Thermal overload protector (TOP) internally connected
Protection class	I (if protective earth is connected by customer to the housing's connection point)
Conformity with standards	EN 61800-5-1; CE
Approval	EAC

Product drawing

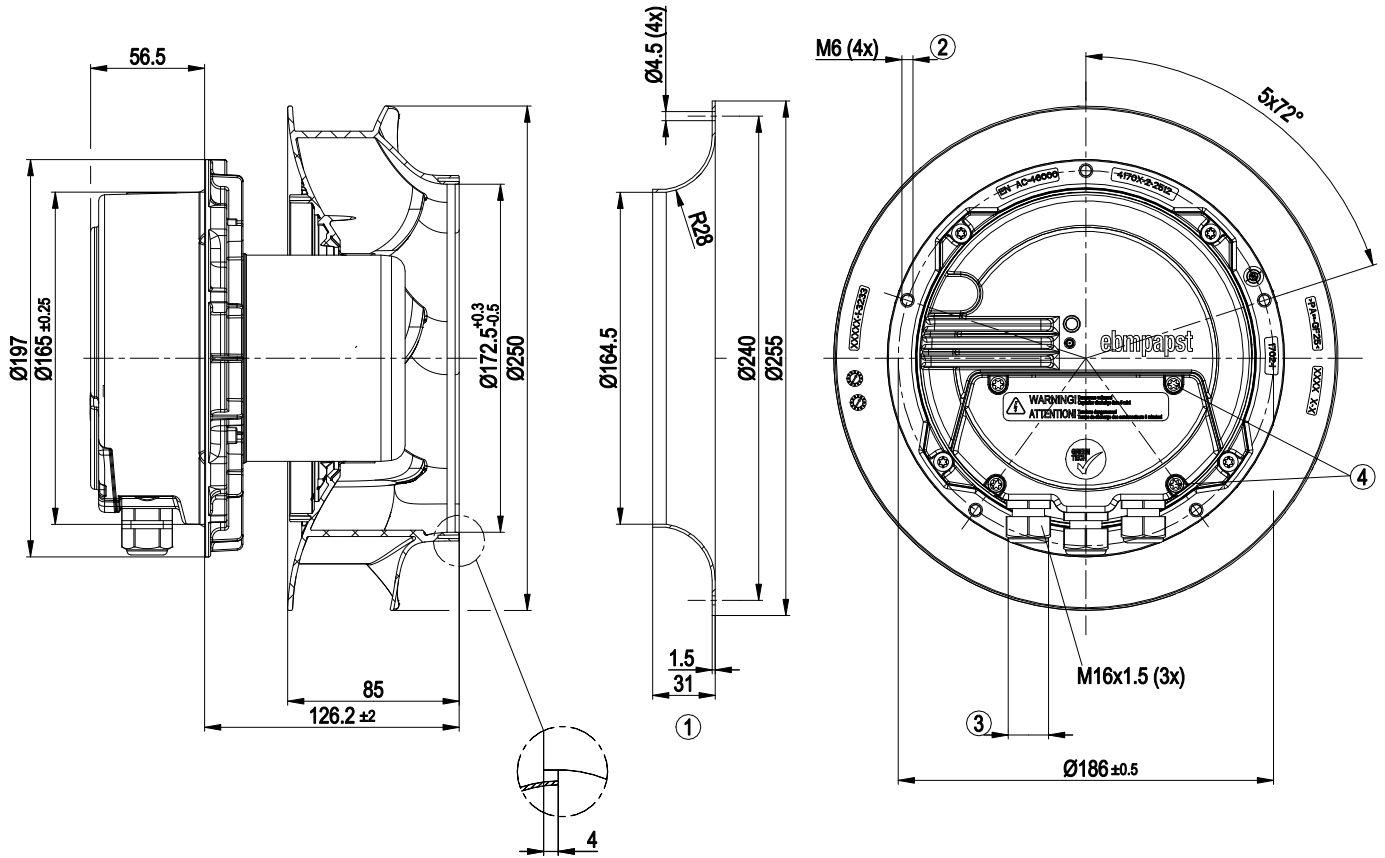

1	Accessory part: Inlet ring 96359-2-4013 not included in scope of delivery
2	Max. clearance for screw 16 mm
3	Cable diameter min. 4 mm, max. 10 mm; tightening torque 2.5 ± 0.4 Nm
4	Tightening torque 3.5 ± 0.5 Nm



Connection diagram

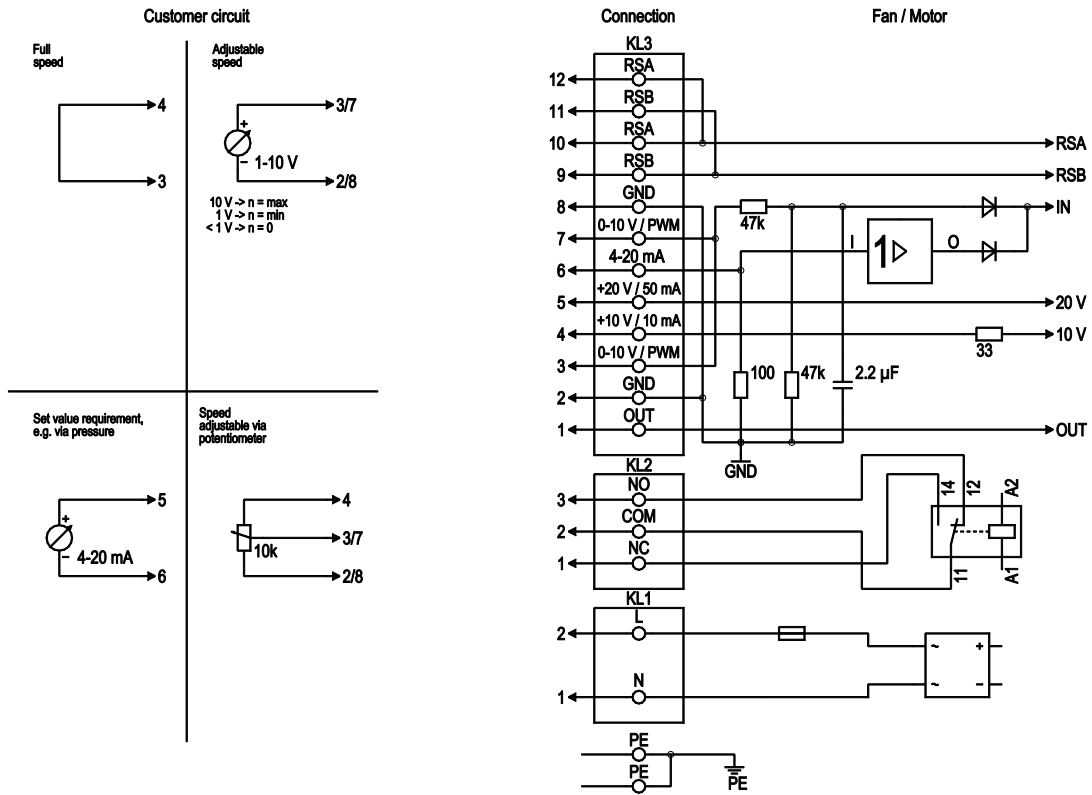

No.	Conn.	Designation	Function/assignment
PE	-	PE	Protective earth terminal
KL1	1, 2	N, L	Power supply 50/60 Hz
KL2	1	NC	Floating status contact, break for failure
KL2	2	COM	Floating status contact, changeover contact, common connection (2 A, max. 250 VAC, min. 10 mA, AC1)
KL2	3	NO	Floating status contact, make for failure
KL3	1	OUT	Analog output, 0-10 VDC, max. 3 mA, SELV output of current motor modulation level: 1 V corresponds to 10% modulation level. 10 V corresponds to 100% modulation level.
KL3	2, 8	GND	Reference ground for control interface, SELV
KL3	3, 7	0-10 V	Control/current sensor value input 0-10 VDC, impedance 100 kΩ, use only as alternative to 4-20 mA input, SELV
KL3	4	+10 V	Voltage output 10 VDC (+/- 3%), max. 10 mA, power supply for ext. devices (e.g. potentiometer), SELV
KL3	5	+20 V	Voltage output 20 VDC (+25%/-10%), max. 50 mA power supply for ext. devices (e.g. sensors), SELV
KL3	6	4-20 mA	Control/current sensor value input 4-20 mA, impedance 100 Ω, use only as alternative to 0-10 V input, SELV
KL3	9, 11	RSB	RS485 interface for MODBUS, RSB
KL3	10, 12	RSA	RS485 interface for MODBUS, RSA



Curves: Air performance 50 Hz

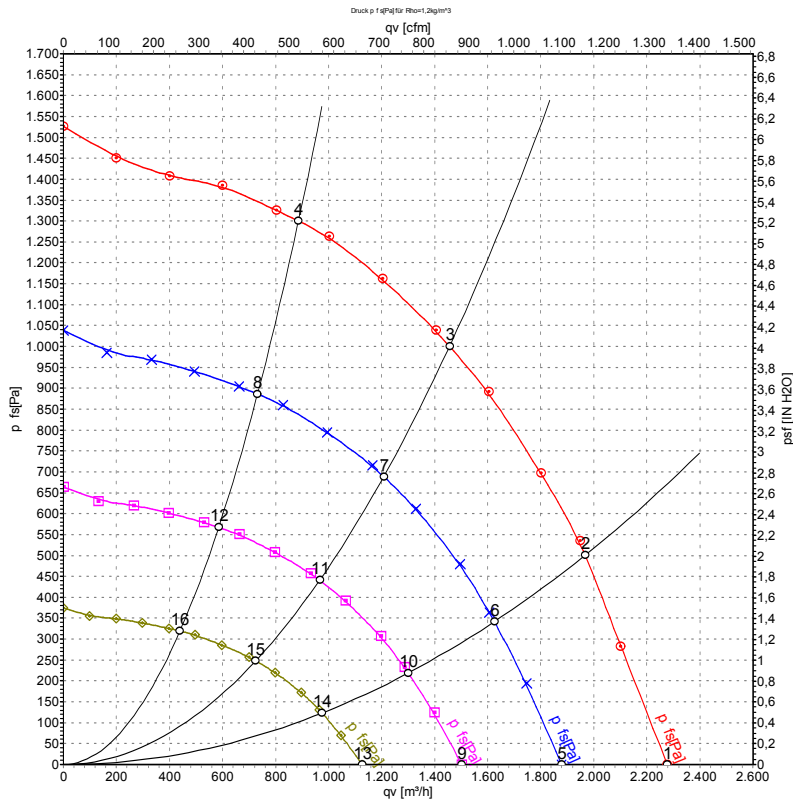

Measurement: LU-139950-1

Air performance measured according to ISO 5801 installation category A. For detailed information on the measurement setup, contact ebmpapst. Intake sound level: Sound power level according to ISO 13347 / sound pressure level measured at 1 m distance from fan axis. The values given are valid under the specified measuring conditions and may vary due to conditions of installation. For deviations from the standard configuration, the parameters have to be checked on the installed unit.

Measured values

	U	f	n	P _{ed}	I	LpA _{in}	LwA _{in}	q _v	P _{fs}	q _v	P _{fs}
	V	Hz	min ⁻¹	W	A	dB(A)	dB(A)	m ³ /h	Pa	cfm	in. wg
1	230	50	4200	582	2.59	82	90	2275	0	1340	0.00
2	230	50	4200	690	3.07	80	88	1965	500	1160	2.01
3	230	50	4200	750	3.30	76	84	1455	1000	855	4.01
4	230	50	4200	679	3.02	78	86	885	1300	520	5.22
5	230	50	3500	326	1.46	77	85	1880	0	1105	0.00
6	230	50	3500	388	1.72	76	83	1625	343	955	1.38
7	230	50	3500	425	1.89	71	79	1210	689	710	2.77
8	230	50	3500	382	1.70	73	81	730	886	430	3.56
9	230	50	2800	167	0.75	72	79	1505	0	885	0.00
10	230	50	2800	198	0.88	70	77	1300	220	765	0.88
11	230	50	2800	218	0.97	66	73	965	441	570	1.77
12	230	50	2800	196	0.87	67	75	585	567	345	2.28
13	230	50	2100	71	0.31	64	72	1125	0	665	0.00
14	230	50	2100	84	0.37	63	70	975	124	575	0.50
15	230	50	2100	92	0.41	58	66	725	248	425	1.00
16	230	50	2100	83	0.37	60	68	440	319	260	1.28

U = Voltage · f = Frequency · n = Speed (rpm) · P_{ed} = Power consumption · I = Current draw · LpA_{in} = Sound pressure level intake side · LwA_{in} = Sound power level intake side
 q_v = Air flow · p_{fs} = Pressure increase

