

R3G250-RO40-A4 ebmpapst Datasheet

sales@fansco.com

www.fansco.com

Limited partnership · Headquarters Mulfingen

Amtsgericht (court of registration) Stuttgart · HRA 590344

General partner Elektrobau Mulfingen GmbH · Headquarters Mulfingen

Amtsgericht (court of registration) Stuttgart · HRB 590142



## Nominal data

Type	R3G250-RO40-A4	
Motor	M3G084-DF	
Phase		1~
Nominal voltage	VAC	230
Nominal voltage range	VAC	200 .. 277
Frequency	Hz	50/60
Method of obtaining data		ml
Speed (rpm)	min <sup>-1</sup>	3650
Power consumption	W	480
Current draw	A	2.1
Min. ambient temperature	°C	-25
Max. ambient temperature	°C	60

ml = Max. load · me = Max. efficiency · fa = Free air · cs = Customer specification · ce = Customer equipment  
Subject to change

## Data according to ErP Directive

		Actual	Req. 2015			
01 Overall efficiency $\eta_{es}$	%	60.4	48.1	09 Power consumption $P_{ed}$	kW	0.47
02 Measurement category		A		09 Air flow $q_v$	m <sup>3</sup> /h	1200
03 Efficiency category		Static		09 Pressure increase $p_{fs}$	Pa	784
04 Efficiency grade N		74.3	62	10 Speed (rpm) n	min <sup>-1</sup>	3635
05 Variable speed drive		Yes		11 Specific ratio*		1.01

Data obtained at optimum efficiency level.

The ErP data is determined using a motor-impeller combination in a standardized measurement setup.

\* Specific ratio =  $1 + p_{fs} / 100\,000\text{ Pa}$

LU-131738



## Technical description

Weight	4.1 kg
Fan size	250 mm
Rotor surface	Painted black
Electronics housing material	Die-cast aluminum
Impeller material	PA6 plastic, glass-fiber reinforced
Number of blades	7
Direction of rotation	Clockwise, viewed toward rotor
Degree of protection	IP54
Insulation class	"B"
Moisture (F) / Environmental (H) protection class	F3-1
Max. permitted ambient temp. for motor (transport/storage)	+ 80 °C
Min. permitted ambient temp. for motor (transport/storage)	- 40 °C
Installation position	Shaft horizontal or rotor on top; rotor on bottom on request
Condensation drainage holes	None
Mode	S1
Motor bearing	Ball bearing
Technical features	<ul style="list-style-type: none"> <li>- Output 10 VDC, max. 10 mA</li> <li>- Alarm relay</li> <li>- Motor current limitation</li> <li>- PFC, active</li> <li>- Soft start</li> <li>- Control input 0-10 VDC / PWM</li> <li>- Control interface with SELV potential safely disconnected from the mains</li> <li>- Thermal overload protection for electronics/motor</li> <li>- Line undervoltage / phase failure detection</li> </ul>
EMC immunity to interference	According to EN 61000-6-2
EMC circuit feedback	According to EN 61000-3-2/3
EMC interference emission	According to EN 55022 (Class B)
Touch current according to IEC 60990 (measuring circuit Fig. 4, TN system)	<= 3.5 mA
Motor protection	Thermal overload protector (TOP) internally connected
With cable	Variable
Protection class	I (with customer connection of protective earth)
Conformity with standards	EN 60335-1; CE
Approval	CSA C22.2 No. 77; UL 2111

Product drawing

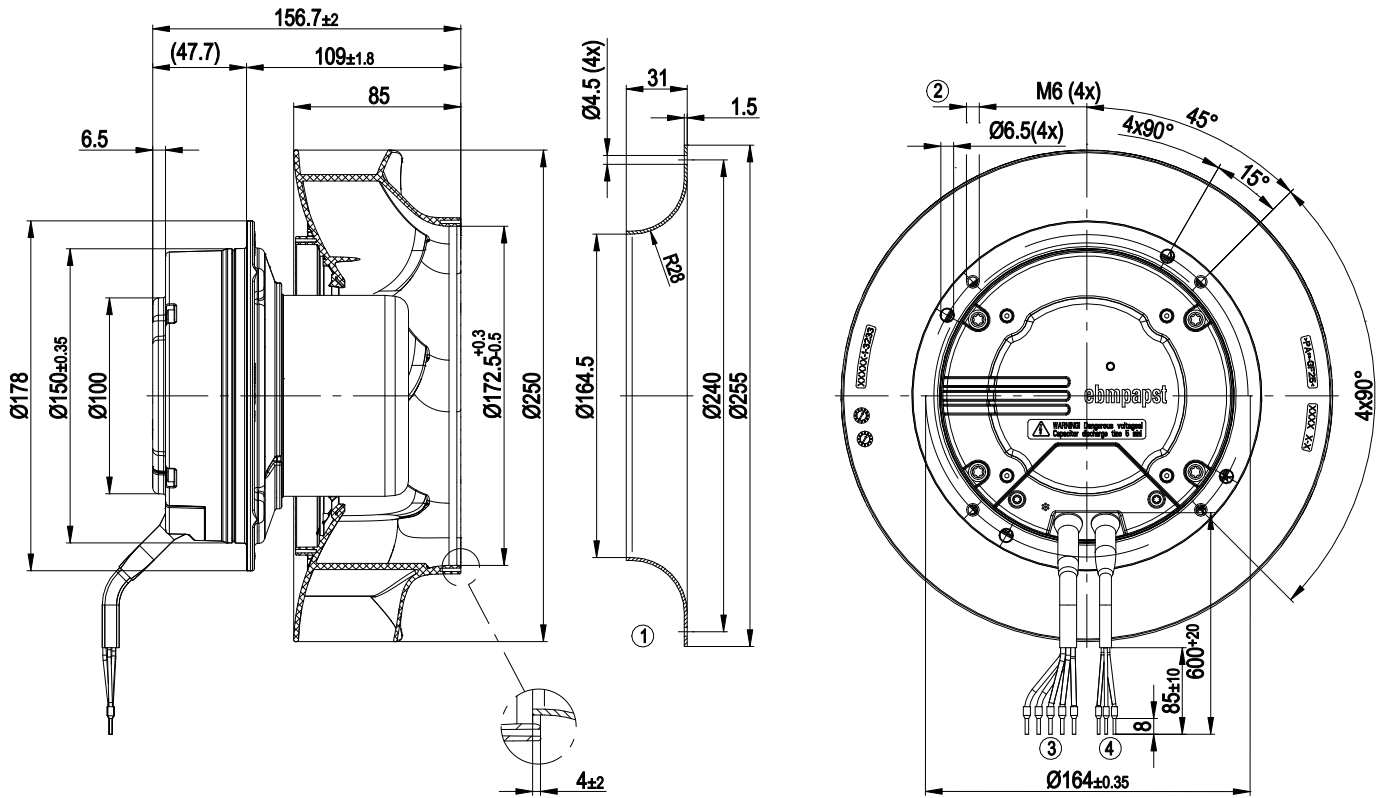

1	Accessory part: Inlet ring 96359-2-4013 not included in scope of delivery, other inlet rings on request
2	Clearance for screw 8 - 10 mm
3	Cable PVC AWG 18, 5x crimped ferrules
4	Cable PVC AWG 22, 3x crimped ferrules



## Connection diagram

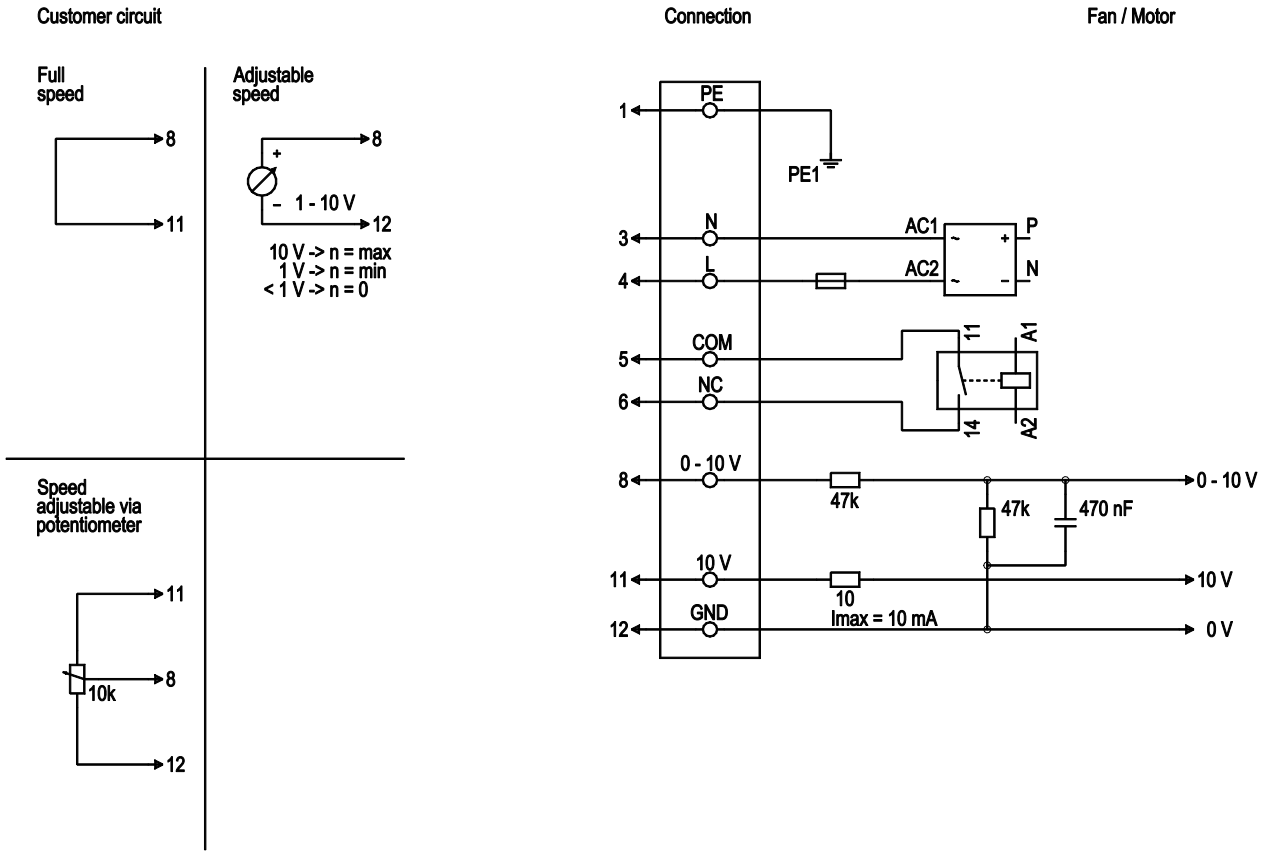

No.	Conn.	Designation	Color	Function/assignment
1	1	PE	green/yellow	Protective earth
1	3	N	blue	Power supply, neutral conductor, 50/60 Hz
1	4	L	black	Power supply, phase, 50/60 Hz
1	5	COM	white 1	Floating status contact, break for failure (2 A, max. 250 VAC, min. 10 mA)
1	6	NC	white 2	Floating status contact, break for failure
2	8	0 - 10 V	yellow	Control input, set value 0-10 VDC, impedance 100 kΩ, SELV
2	11	10 VDC	red	Voltage output 10 VDC (±3%), max. 10 mA, power supply for external devices (e.g. potentiometer), SELV
2	12	GND	blue	Reference ground for control interface, SELV

## Curves: Air performance 50 Hz

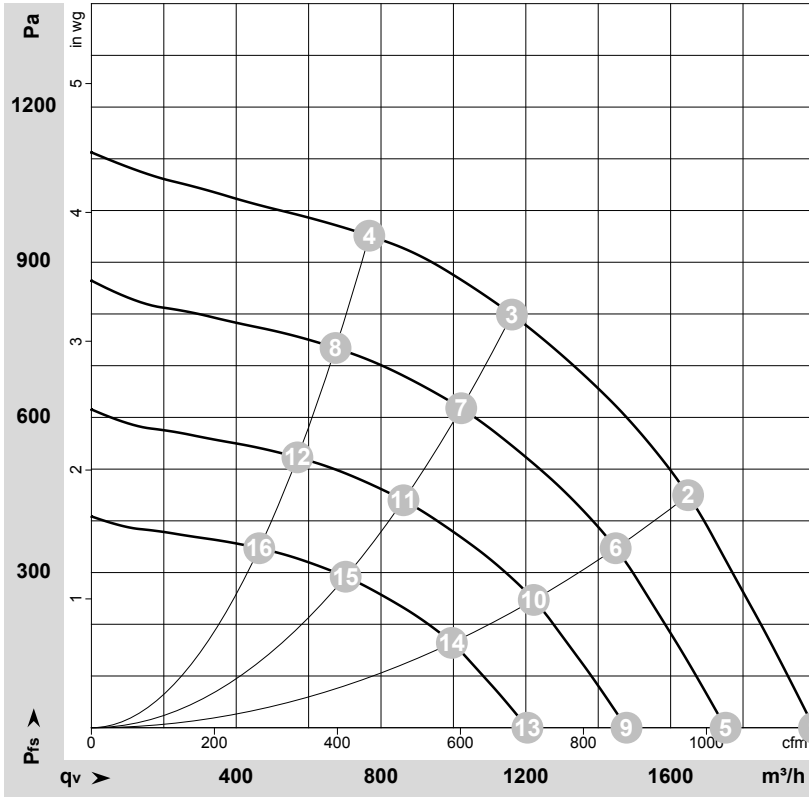

$\rho = 1.15 \text{ kg/m}^3 \pm 2 \%$

Measurement: LU-131738-1

Air performance measured according to ISO 5801 installation category A. For detailed information on the measurement setup, contact ebmpapst. Intake sound level: Sound power level according to ISO 13347 / sound pressure level measured at 1 m distance from fan axis. The values given are valid under the specified measuring conditions and may vary due to conditions of installation. For deviations from the standard configuration, the parameters have to be checked on the installed unit.

## Measured values

	U	f	n	P <sub>ed</sub>	I	LpA <sub>in</sub>	LwA <sub>in</sub>	qv	p <sub>fs</sub>	qv	p <sub>fs</sub>
	V	Hz	min <sup>-1</sup>	W	A	dB(A)	dB(A)	m <sup>3</sup> /h	Pa	CFM	inH <sub>2</sub> O
1	230	50	3650	382	1.68	76	85	1995	0	1175	0.00
2	230	50	3650	447	1.96	71	79	1650	450	970	1.81
3	230	50	3650	480	2.10	69	77	1160	800	685	3.21
4	230	50	3650	432	1.90	73	82	770	950	450	3.81
5	230	50	3200	258	1.14	73	81	1750	0	1030	0.00
6	230	50	3200	303	1.33	68	76	1450	351	850	1.41
7	230	50	3200	324	1.42	65	73	1020	619	600	2.49
8	230	50	3200	293	1.29	70	78	675	735	395	2.95
9	230	50	2700	155	0.68	69	77	1480	0	870	0.00
10	230	50	2700	182	0.80	64	72	1220	250	720	1.00
11	230	50	2700	195	0.85	61	69	860	440	505	1.77
12	230	50	2700	176	0.77	66	74	570	523	335	2.10
13	230	50	2200	84	0.37	64	72	1205	0	710	0.00
14	230	50	2200	99	0.43	59	67	995	166	585	0.67
15	230	50	2200	105	0.46	56	64	700	292	415	1.17
16	230	50	2200	95	0.42	61	69	465	347	275	1.39

U = Power supply · f = Frequency · n = Speed (rpm) · P<sub>ed</sub> = Power consumption · I = Current draw · LpA<sub>in</sub> = Sound pressure level intake side · LwA<sub>in</sub> = Sound power level intake side  
 qv = Air flow · p<sub>fs</sub> = Pressure increase

