

ebm-papst Ventilator (Shanghai) Co.,Ltd.

No.418, Hua Jing Road, Wai Gao Qiao Free Trade Zone, Pudong

R3G250-PR17-W9/G01 ebmpapst Datasheet

sales@fansco.com

www.fansco.com

## Nominal data

Type	R3G250-PR17-W9/G01	
Motor	M3G084-DF	
Phase		3~
Nominal voltage	VAC	400
Nominal voltage range	VAC	380 .. 480
Frequency	Hz	50/60
Method of obtaining data		ml
Speed (rpm)	min <sup>-1</sup>	4000
Power consumption	W	1160
Current draw	A	1.8
Min. ambient temperature	°C	-25
Max. ambient temperature	°C	60

ml = Max. load · me = Max. efficiency · fa = Free air · cs = Customer specification · ce = Customer equipment  
Subject to change

## Data according to Commission Regulation (EU) 327/2011 (EN 17166)

		Actual	Req. 2015			
01 Overall efficiency $\eta_{es}$	%	66.5	52.2	09 Power consumption $P_{ed}$	kW	1.15
02 Measurement category		A		09 Air flow $q_v$	m <sup>3</sup> /h	2405
03 Efficiency category		Static		09 Pressure increase $p_{fs}$	Pa	1072
04 Efficiency grade N		76.3	62	10 Speed (rpm) n	min <sup>-1</sup>	4005
05 Variable speed drive		Yes		11 Specific ratio*		1.01

Data obtained at optimum efficiency level.

The ErP data is determined using a motor-impeller combination in a standardized measurement setup.

\* Specific ratio =  $1 + p_{fs} / 100\,000\text{ Pa}$

LU-12305

## Technical description

Size	250 mm
Motor size	84
Rotor surface	Painted black
Electronics housing material	Die-cast aluminum
Impeller material	PA plastic
Inlet nozzle material	Sheet steel, galvanized
Number of blades	6
Direction of rotation	Clockwise, viewed toward rotor
Degree of protection	IP55
Insulation class	"F"
Moisture (F) / Environmental (H) protection class	H1
Max. permitted ambient temp. for motor (transport/storage)	+80 °C
Min. permitted ambient temp. for motor (transport/storage)	-40 °C
Installation position	Shaft horizontal or rotor on bottom; rotor on top on request
Condensation drainage holes	On rotor side
Mode	S1
Motor bearing	Ball bearing; (sealed)
Technical features	<ul style="list-style-type: none"> <li>- Output 10 VDC, max. 10 mA</li> <li>- Operation and alarm display</li> <li>- Alarm relay</li> <li>- Integrated PID controller</li> <li>- Power limiter</li> <li>- Motor current limitation</li> <li>- PFC, passive</li> <li>- RS-485 MODBUS-RTU</li> <li>- Soft start</li> <li>- EEPROM write cycles: 100,000 maximum</li> <li>- Control input 0-10 VDC / PWM</li> <li>- Control interface with SELV potential safely disconnected from the mains</li> <li>- Temperature derating</li> <li>- Thermal overload protection for electronics/motor</li> <li>- Line undervoltage / phase failure detection</li> </ul>
EMC immunity to interference	According to EN 61000-6-2 (industrial environment)
EMC interference emission	According to EN 61000-6-3 (household environment), except EN 61000-3-2 for professionally used equipment with a total rated power greater than 1 kW
Touch current according to IEC 60990 (measuring circuit Fig. 4, TN system)	<= 3.5 mA
Motor protection	Thermal overload protector (TOP) internally connected
With cable	Variable
Protection class	I (with customer connection of protective earth)
Conformity with standards	EN 60335-1; EN 61800-5-1; CE
Approval	CSA C22.2 No. 77 + CAN/CSA-E60730-1; EAC; UL 1004-7 + 60730-1

**Product drawing**

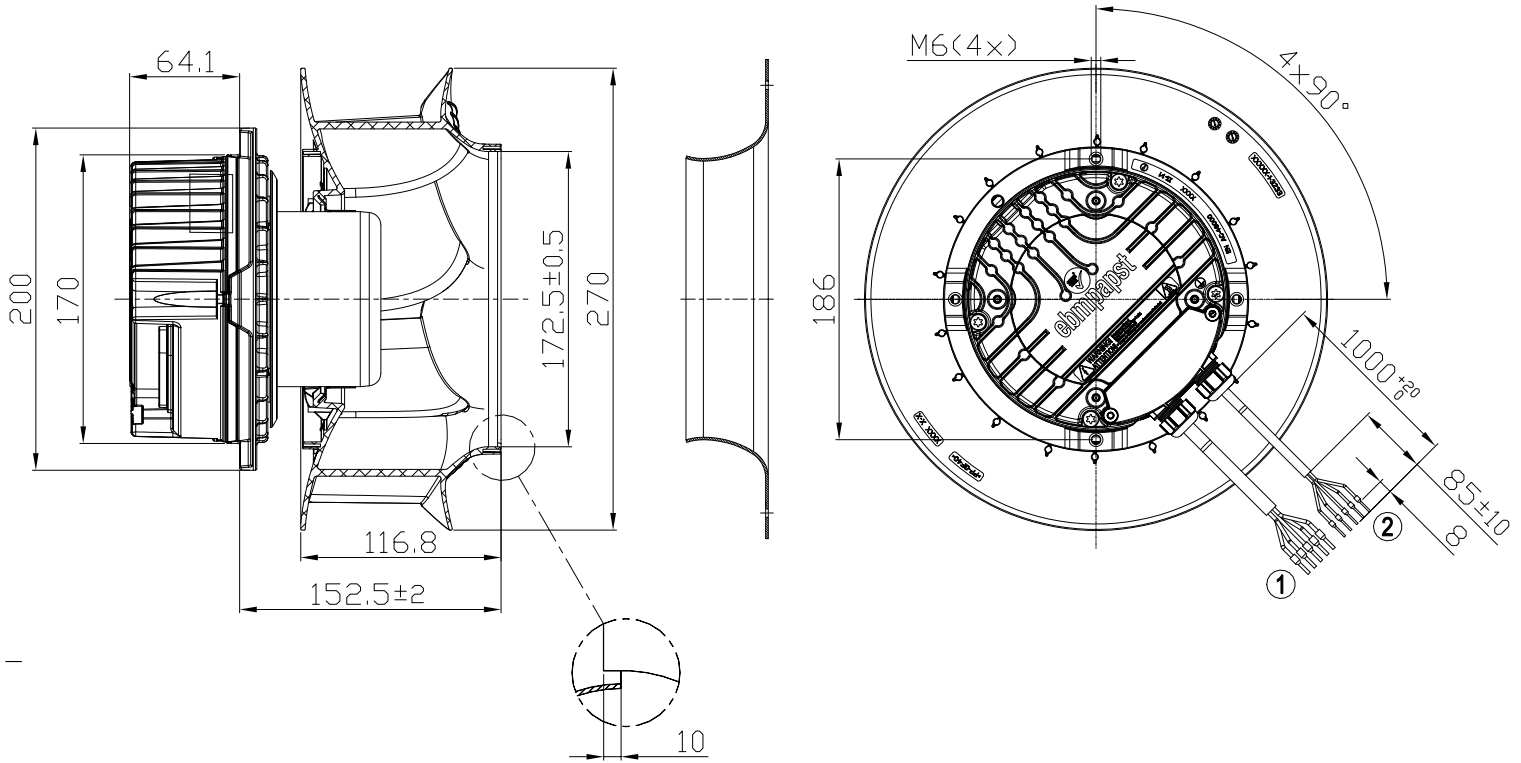

	Accessory part: inlet ring 96350-2-4013 not included in scope of delivery
1	Cable PVC AWG18 6x wire-end ferrule
2	Cable PVC AWG22 5x wire-end ferrule

Accessory part

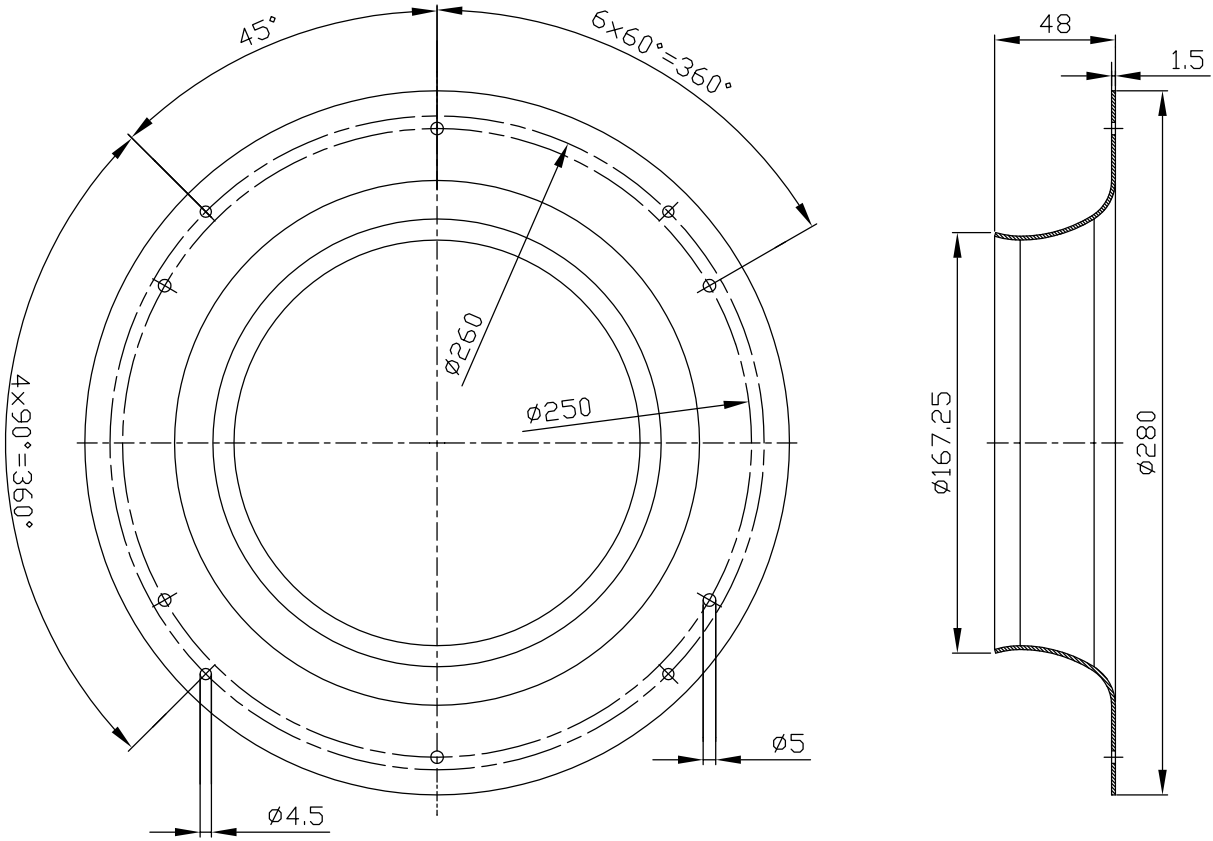

Inlet ring 96350-2-4013

## Connection diagram

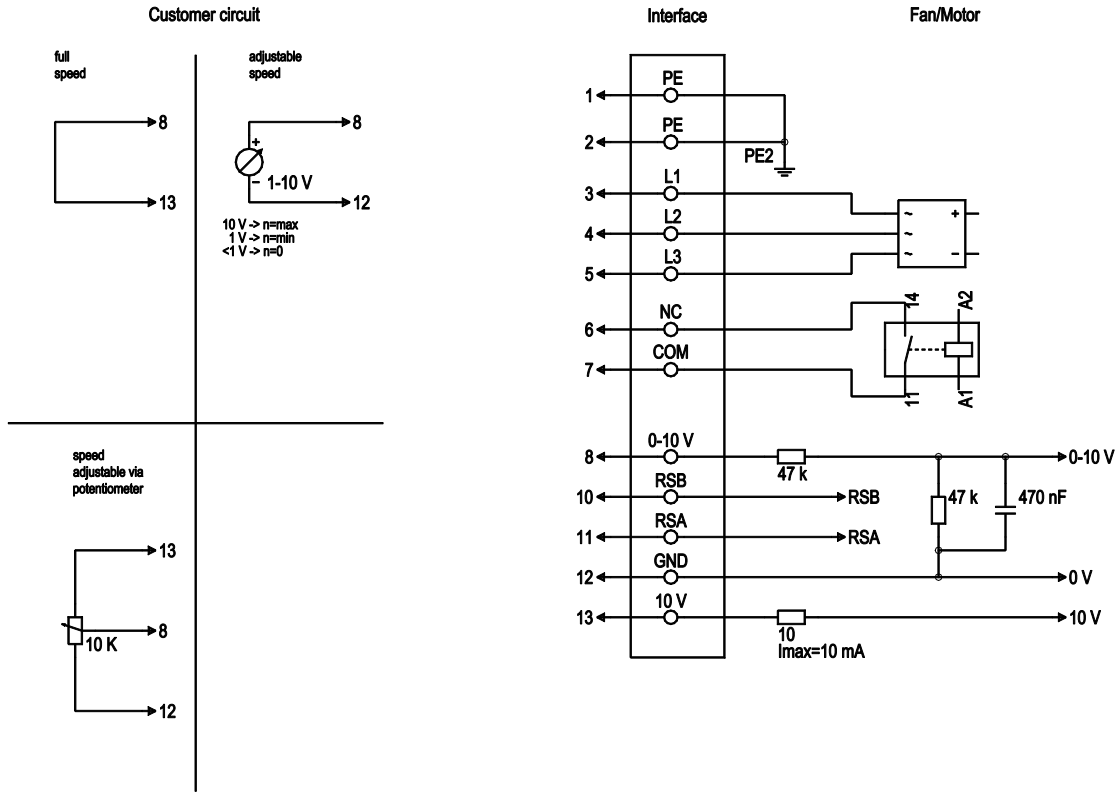

No.	Conn.	Designation	Color	Function/assignment
1	1, 2	PE	green/yellow	Protective earth
1	3, 4, 5	L1, L2, L3	black	Power supply, phase, 50/60 Hz
1	6	NC	white 1	Status relay, floating status contact, break for failure, contact rating 250 VAC/30 VDC 5 A minimum contact gap 1 mA/5 VDC, reinforced insulation on control interface side, functional insulation on supply side
1	7	COM	white 2	Status relay, floating status contact, common connection, contact rating 250 VAC/30 VDC 5 A minimum contact gap 1 mA/5 VDC, reinforced insulation on control interface side, functional insulation on supply side
2	8	0-10V	yellow	Analog input (set value) SELV, 0-10 V, Ri = 100 kΩ, adjustable curve
2	10	RSB	brown	RS485 interface for MODBUS, RSB; SELV
2	11	RSA	white	RS485 interface for MODBUS, RSA; SELV
2	12	GND	blue	Reference ground for control interface, SELV
2	13	+10V	red	Fixed voltage output 10 VDC, SELV, +10 V +/-3%, max. 10 mA, short-circuit-proof, power supply for external devices (e.g. potentiometers)

## Curves: Air performance 50 Hz

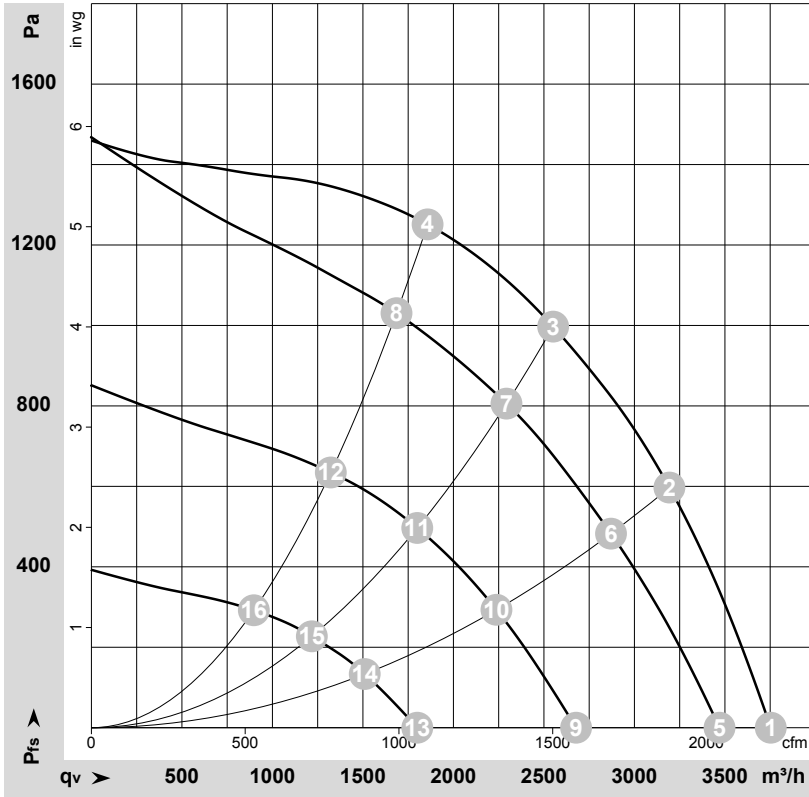

$\rho = 1.15 \text{ kg/m}^3 \pm 2 \%$

Measurement: LU-12305-1

Air performance measured according to ISO 5801 installation category A. For detailed information on the measurement setup, contact ebmpapst. Intake sound level: Sound power level according to ISO 13347 / sound pressure level measured at 1 m distance from fan axis. The values given are valid under the specified measuring conditions and may vary due to conditions of installation. For deviations from the standard configuration, the parameters have to be checked on the installed unit.

## Fan performance

	Wired	U	f	n	P <sub>ed</sub>	I	q <sub>v</sub>	P <sub>fs</sub>	q <sub>v</sub>	P <sub>fs</sub>
		V	Hz	min <sup>-1</sup>	W	A	m <sup>3</sup> /h	Pa	cfm	in. wg
1	Y	400	50	4000	810	1.30	3755	0	2210	0.00
2	Y	400	50	4000	1094	1.75	3195	600	1880	2.41
3	Y	400	50	4000	1160	1.80	2550	1000	1500	4.01
4	Y	400	50	4000	1100	1.75	1855	1250	1095	5.02
5	Y	400	50	3775	695	1.15	3470	0	2040	0.00
6	Y	400	50	3630	836	1.35	2870	483	1690	1.94
7	Y	400	50	3595	843	1.36	2295	806	1350	3.24
8	Y	400	50	3610	823	1.33	1685	1032	990	4.14
9	Y	400	50	2930	333	0.63	2680	0	1575	0.00
10	Y	400	50	2845	412	0.73	2240	293	1315	1.18
11	Y	400	50	2835	423	0.75	1800	497	1060	2.00
12	Y	400	50	2845	417	0.74	1325	635	780	2.55
13	Y	400	50	1985	125	0.30	1800	0	1060	0.00
14	Y	400	50	1945	149	0.34	1510	134	890	0.54
15	Y	400	50	1940	154	0.35	1220	227	715	0.91
16	Y	400	50	1940	153	0.35	895	292	530	1.17

Wired = Wiring · U = Voltage · f = Frequency · n = Speed (rpm) · P<sub>ed</sub> = Power consumption · I = Current draw · LpA<sub>in</sub> = Sound pressure level intake side · LwA<sub>in</sub> = Sound power level intake side  
 q<sub>v</sub> = Air flow · p<sub>fs</sub> = Pressure increase

