

R3G250-BB09-S1 ebmpapst Datasheet

sales@fansco.com

www.fansco.com

Limited partnership · Headquarters Mulfingen

Amtsgericht (court of registration) Stuttgart · HRA 590344

General partner Elektrobau Mulfingen GmbH · Headquarters Mulfingen

Amtsgericht (court of registration) Stuttgart · HRB 590142

Nominal data

Type	R3G250-BB09-S1	
Motor	M3G084-DF	
Nominal voltage	VDC	110
Nominal voltage range	VDC	77 .. 138
Frequency	Hz	DC
Method of obtaining data		ml
Speed (rpm)	min ⁻¹	3600
Power consumption	W	800
Current draw	A	7.3
Min. ambient temperature	°C	-40
Max. ambient temperature	°C	60

ml = Max. load · me = Max. efficiency · fa = Free air · cs = Customer specification · ce = Customer equipment
Subject to change

Data according to Commission Regulation (EU) 327/2011 (EN 17166)

		Actual	Req. 2015			
01 Overall efficiency η_{es}	%	59.6	50.5	09 Power consumption P_e	kW	0.8
02 Measurement category		A		09 Air flow q_v	m ³ /h	1805
03 Efficiency category		Static		09 Pressure increase p_{fs}	Pa	882
04 Efficiency grade N		71.1	62	10 Speed (rpm) n	min ⁻¹	3610
05 Variable speed drive		Yes		11 Specific ratio*		1.01

Data obtained at optimum efficiency level.

* Specific ratio = $1 + p_s / 100\,000\text{ Pa}$

LU-194263

The efficiency values displayed for achieving conformity with the Ecodesign Regulation EU 327/2011 has been reached with defined air duct components (e.g. inlet rings).
The dimensions must be requested from ebm-papst. If other air conduction geometries are used on the installation side, the ebm-papst evaluation loses its validity/the conformity must be confirmed again.
The product does not fall within the scope of Regulation (EU) 2019/1781 due to the exception specified in Article 2 (2a) (motors completely integrated into a product).



Technical description

Weight	5.1 kg
Size	250 mm
Motor size	84
Rotor surface	Painted black
Electronics housing material	Die-cast aluminum
Impeller material	Sheet aluminum
Number of blades	7
Direction of rotation	Clockwise, viewed toward rotor
Degree of protection	IP55
Insulation class	"F"
Moisture (F) / Environmental (H) protection class	H3
Max. permitted ambient temp. for motor (transport/storage)	+80 °C
Min. permitted ambient temp. for motor (transport/storage)	-40 °C
Installation position	Shaft horizontal or rotor on bottom; rotor on top on request
Condensation drainage holes	On rotor side
Mode	S1
Motor bearing	Ball bearing; (sealed)
Technical features	<ul style="list-style-type: none"> - Output 10 VDC, max. 10 mA - Operation and alarm display - Alarm relay - Motor current limitation - RS-485 MODBUS-RTU - Soft start - EEPROM write cycles: 100,000 maximum - Control input 0-10 VDC / PWM - Control interface with SELV potential safely disconnected from the mains - Overvoltage detection - Thermal overload protection for electronics/motor - Line undervoltage detection
EMC regulations	According to EN 50121-3-2
Motor protection	Thermal overload protector (TOP) internally connected
With cable	Lateral
Protection class assignment	<p>I; If a protective earth is connected by the customer</p> <p>This component for installation may have several local protection classes. This information relates to this component's basic design.</p> <p>The final protection class is based on the component's intended installation and connection.</p>
Conformity with standards	EN 15085-1, CPC3; EN 45545-2, HL3; EN 50155; EN 61373, Cat. 1B; CE
Approval	EAC
Comment	<p>If voltage (e.g. 230 VAC) is passed through the alarm relay, the SELV signal wires lose their property of reinforced insulation, meaning they then have only basic insulation</p> <p>The SELV property (reinforced insulation) is not lost when voltages of up to 110 VDC are passed through the alarm relay.</p>

EC centrifugal fan - RadiPac

backward-curved, single-intake

for rail applications

Product drawing

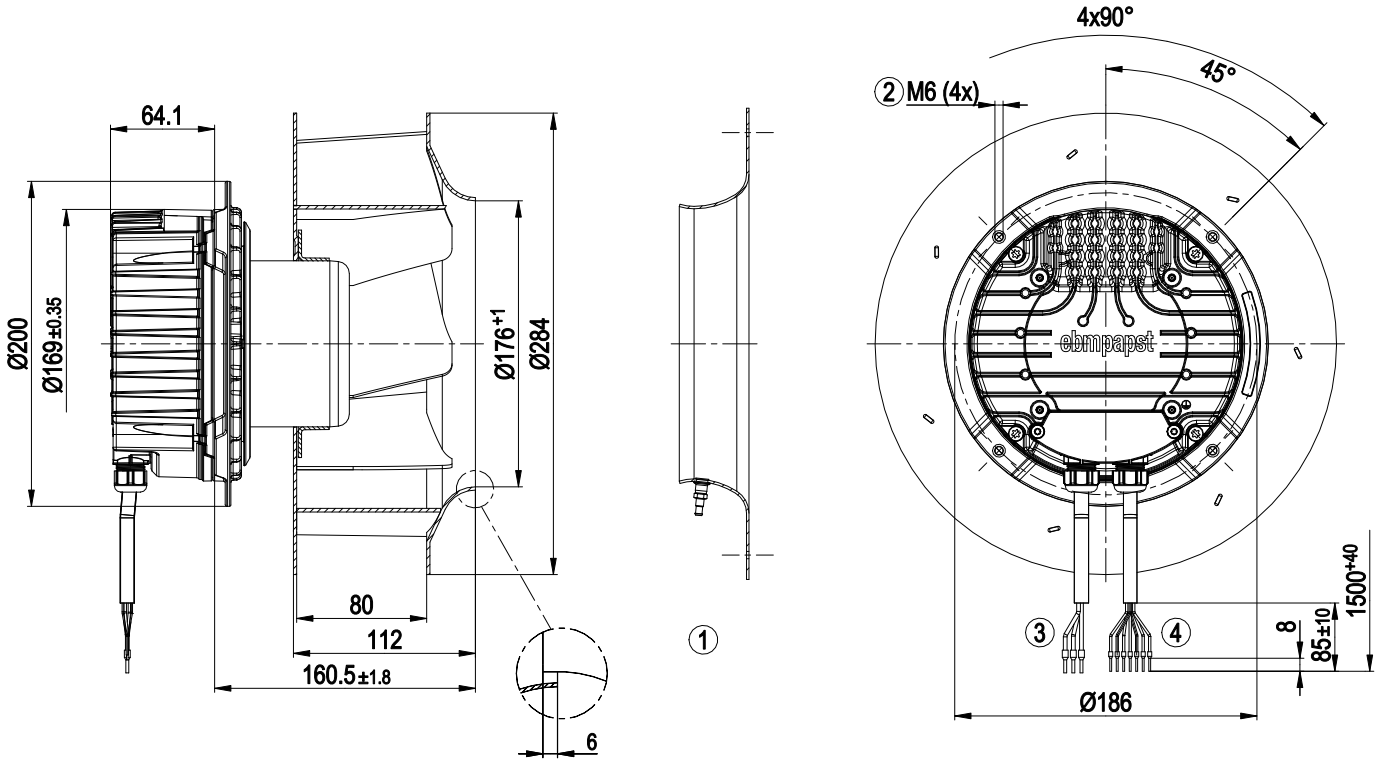

1	Accessory part: Inlet ring 25075-2-4013 with pressure tap (k-factor: 70) not included in scope of delivery
2	Max. clearance for screw 16 mm
3	Cable, halogen-free, railway application EN 45545, 4G 1.5 mm ² 3x wire-end ferrule, 1x wire not routed externally
4	Cable, halogen-free, railway application EN 45545, 7x 0.5 mm ² 7x wire-end ferrule



EC centrifugal fan - RadiPac

backward-curved, single-intake

for rail applications

Accessory part

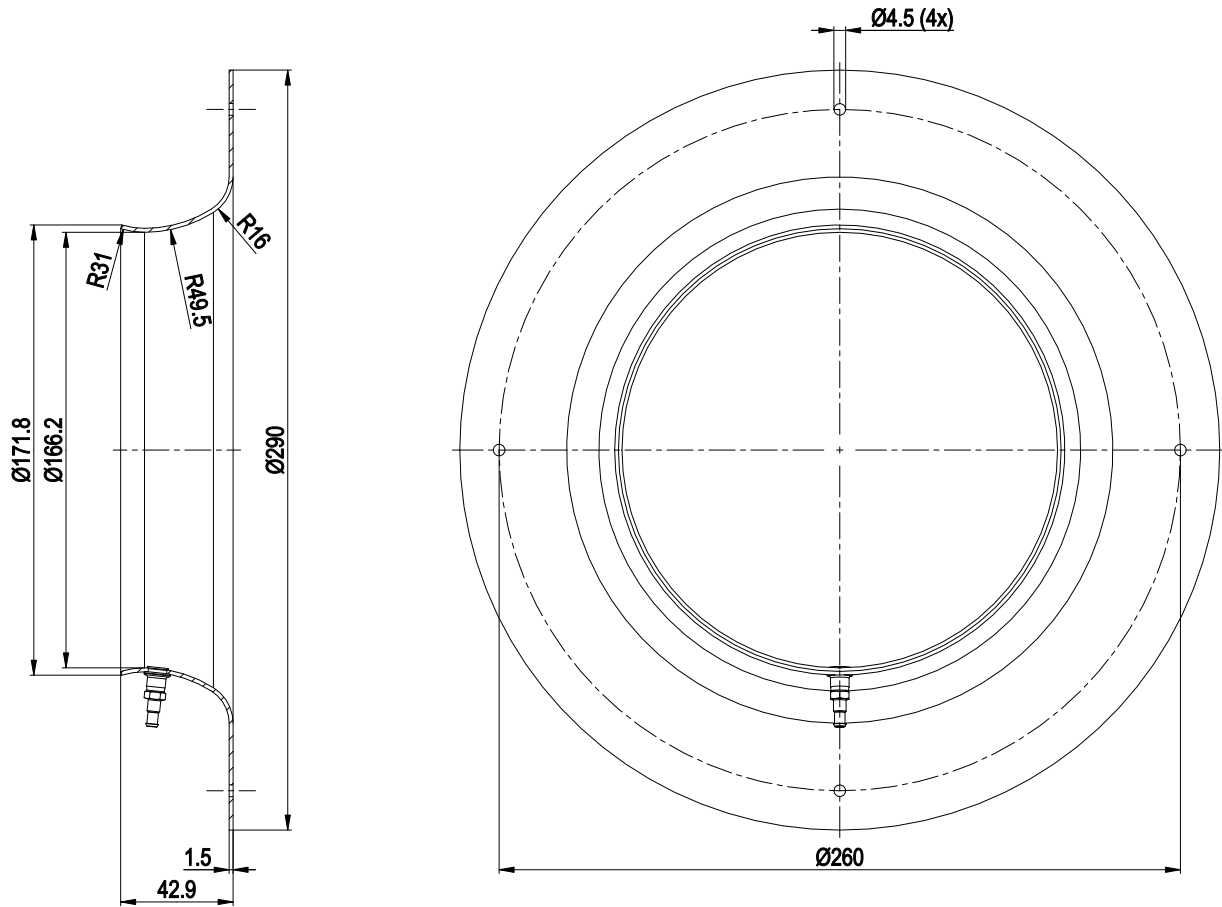

Inlet ring 25075-2-4013 with pressure tap not included in scope of delivery



EC centrifugal fan - RadiPac

backward-curved, single-intake
for rail applications

Connection diagram

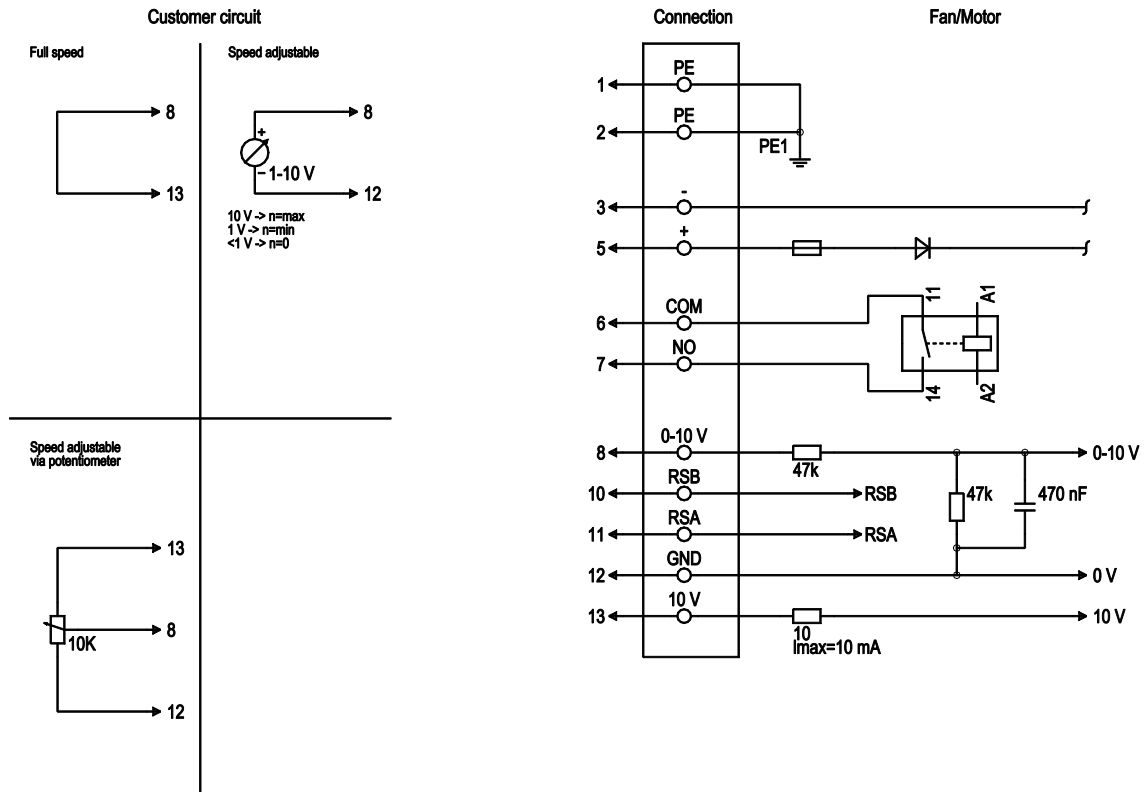

No.	Conn.	Designation	Color	Function/assignment
1	1	PE	green/yellow	Protective earth
1	2	PE	-	not brought out via wire
1	3	-	black	Power supply, GND, voltage range see nameplate
1	5	+	brown	Power supply, see nameplate for voltage range
2	6	COM	gray	Status relay, floating status contact, common connection, contact rating 250 VAC/30 VDC max. 2 A (AC1), min. 1 mA/5 VDC, reinforced insulation on control interface side, basic insulation on supply side in accordance with EN 50124-1
2	7	NO	orange	Status relay, floating status contact, normally open contact, contact rating 250 VAC/30 VDC max. 2 A (AC1), min. 1 mA/5 VDC, reinforced insulation on control interface side, basic insulation on supply side in accordance with EN 50124-1
2	8	0-10 V	yellow	Analog input (set value) SELV, 0-10 V, Ri = 100 kΩ, adjustable curve
2	10	RSB	brown	RS-485 interface for MODBUS, RSB; SELV, bus termination resistor provided by customer
2	11	RSA	white	RS-485 interface for MODBUS, RSA; SELV, bus termination resistor provided by customer
2	12	GND	blue	Reference ground for control interface; SELV
2	13	+10 V	red	Fixed voltage output 10 VDC, SELV, +10 V +/-3%, max. 10 mA, short-circuit-proof, power supply for external devices (e.g. potentiometers)



Curves: Air performance

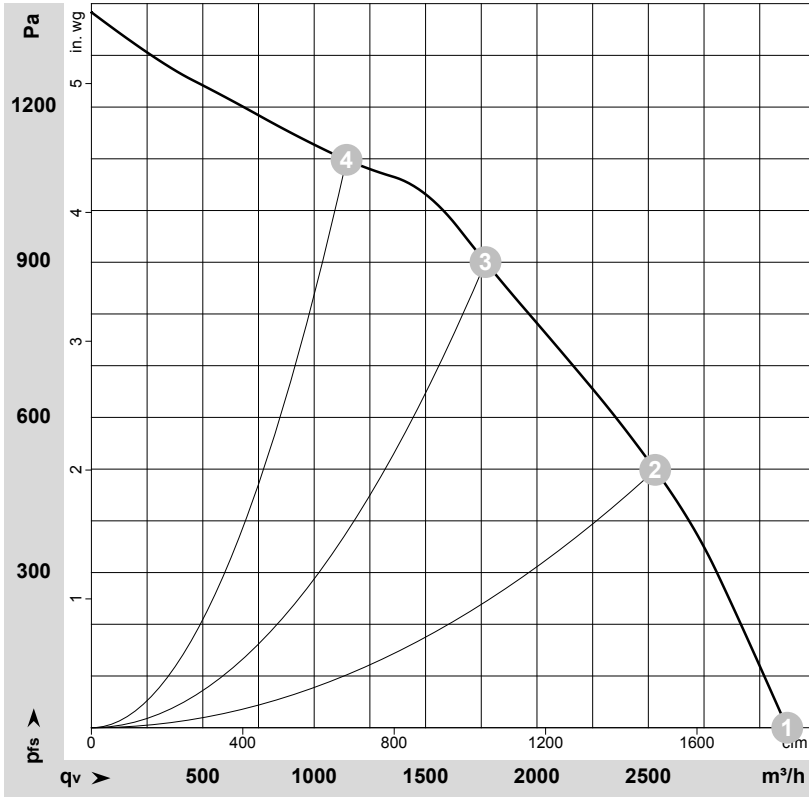

$\rho = 1.15 \text{ kg/m}^3 \pm 2 \%$

Measurement: LU-194263-1

Air performance measured according to ISO 5801 installation category A. For detailed information on the measurement setup, contact ebmpapst. Intake sound level: Sound power level according to ISO 13347 / sound pressure level measured at 1 m distance from fan axis. The values given are valid under the specified measuring conditions and may vary due to conditions of installation. For deviations from the standard configuration, the parameters have to be checked on the installed unit.

Measured values

	U	n	P _{ed}	I	LpA _{in}	LwA _{in}	q _v	p _{fs}	q _v	p _{fs}
	V	min ⁻¹	W	A	dB(A)	dB(A)	m ³ /h	Pa	cfm	in. wg
1	110	3695	671	6.10	78	85	3125	0	1840	0.00
2	110	3635	765	6.95	73	81	2530	500	1490	2.01
3	110	3600	800	7.30	71	79	1770	900	1040	3.61
4	110	3660	759	6.90	78	86	1145	1100	675	4.42

U = Voltage · n = Speed (rpm) · P_{ed} = Power consumption · I = Current draw · LpA_{in} = Sound pressure level intake side · LwA_{in} = Sound power level intake side · q_v = Air flow
 p_{fs} = Pressure increase

