

R3G250-BA52-11 ebmpapst Datasheet

sales@fansco.com

www.fansco.com

Limited partnership · Headquarters Muldingen
County court Stuttgart · HRA 590344

General partner Elektrobau Muldingen GmbH · Headquarters Muldingen
County court Stuttgart · HRB 590142



Nominal data

Type	R3G250-BA52-11	
Motor	M3G074-CF	
Phase		1~
Nominal voltage	VAC	230
Type of data definition		ml
Speed	min ⁻¹	2660
Power input	W	170
Current draw	A	1.4
Min. ambient temperature	°C	-25
Max. ambient temperature	°C	40

ml = max. load · me = max. efficiency · fa = running at free air · cs = customer specs · cu = customer unit
Subject to alterations

Data according to ErP directive

Installation category	A
Efficiency category	Static
Variable speed drive	Yes
Specific ratio*	1.00

* Specific ratio = $1 + p_b / 100\,000\text{ Pa}$

		Actual	Request 2013	Request 2015
Overall efficiency η_{es}		57.7	39.1	43.1
Efficiency grade N		76.6	58	62
Power input P_{ed}	kW	0.16		
Air flow q_v	m ³ /h	1000		
Pressure increase p_{fs}	Pa	302		
Speed n	min ⁻¹	2645		

Data established at point of optimum efficiency



Technical features

Mass	2.9 kg
Size	250 mm
Surface of rotor	Coated in black
Material of impeller	Sheet steel, galvanised
Direction of rotation	Clockwise, seen on rotor
Type of protection	IP 44; Depending on installation and position
Insulation class	"B"
Humidity class	F3-1
Max. permissible ambient motor temp. (transp./ storage)	+ 80 °C
Min. permissible ambient motor temp. (transp./storage)	- 40 °C
Mounting position	Any
Condensate discharge holes	None
Cooling bore / aperture	Rotor-side
Operation mode	S1
Motor bearing	Ball bearing
Technical features	<ul style="list-style-type: none"> - Output 10 VDC, max. 1.1 mA - Tach output - Motor current limit - Soft start - Control input 0-10 VDC / PWM - Control interface with SELV potential safely disconnected from the mains - Over-temperature protected electronics / motor
EMC interference immunity	Acc. to EN 61000-6-2 (industrial environment)
EMC harmonics	Acc. to EN 61000-3-2/3
EMC interference emission	Acc. to EN 61000-6-3 (household environment)
Touch current acc. IEC 60990 (measuring network Fig. 4, TN system)	<= 3.5 mA
Motor protection	Thermal overload protector (TOP) wired internally
Cable exit	Variable
Protection class	I (if protective earth is connected by customer)
Product conforming to standard	EN 60335-1
Approval	UL 2111; CSA C22.2 Nr.77

Product drawing

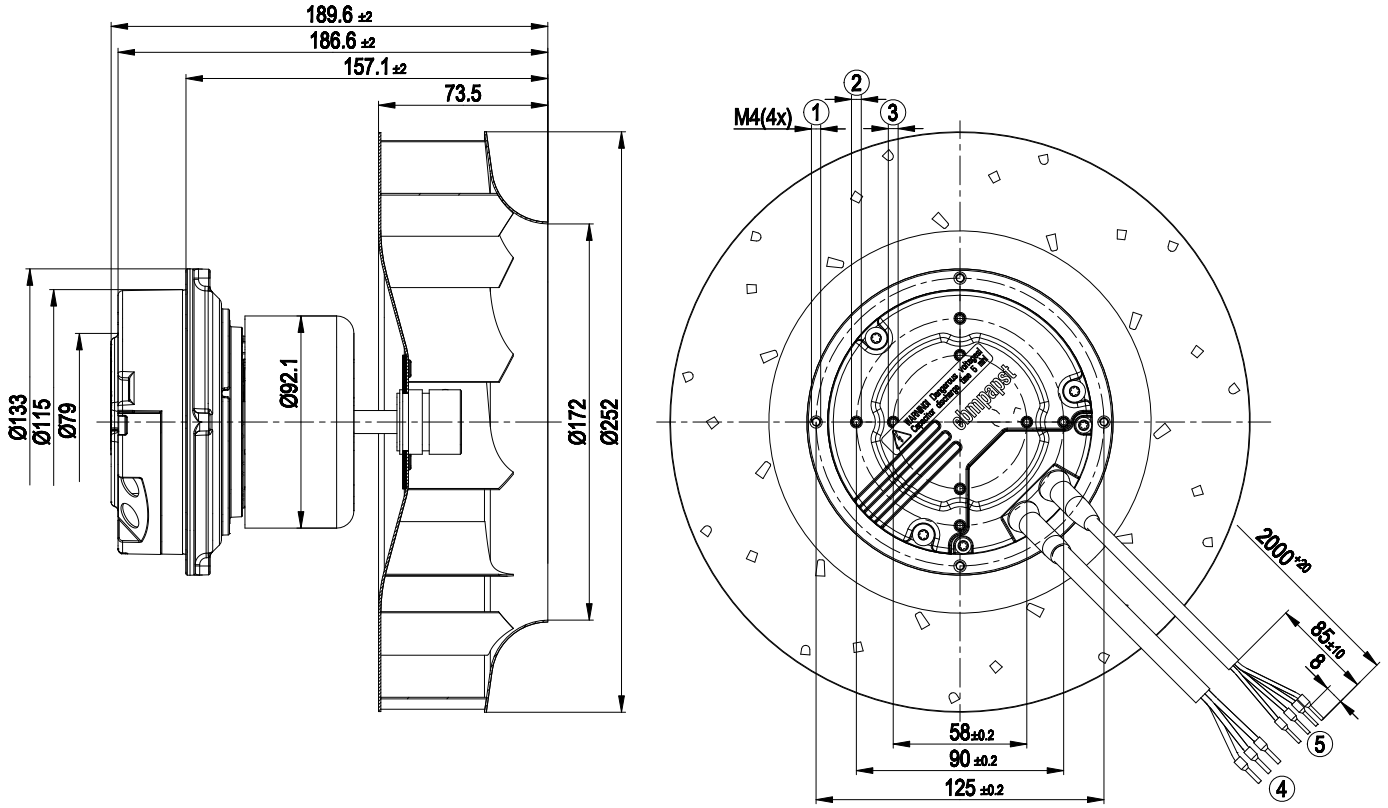

- | | |
|---|--|
| 1 | Depth of screw 8 - 10 mm, tightening torque 2.5±0.2 Nm; gluing the screws is recommended |
| 2 | Pilot hole prepared for self-tapping screw M4, depth of screw max. 6 mm |
| 3 | Pilot hole prepared for self-tapping screw M4, depth of screw max. 8 mm |
| 4 | Connection line AWG18, 3 x crimped core-end sleeves |
| 5 | Connection line AWG22, 4 x crimped core-end sleeves |

Connection screen

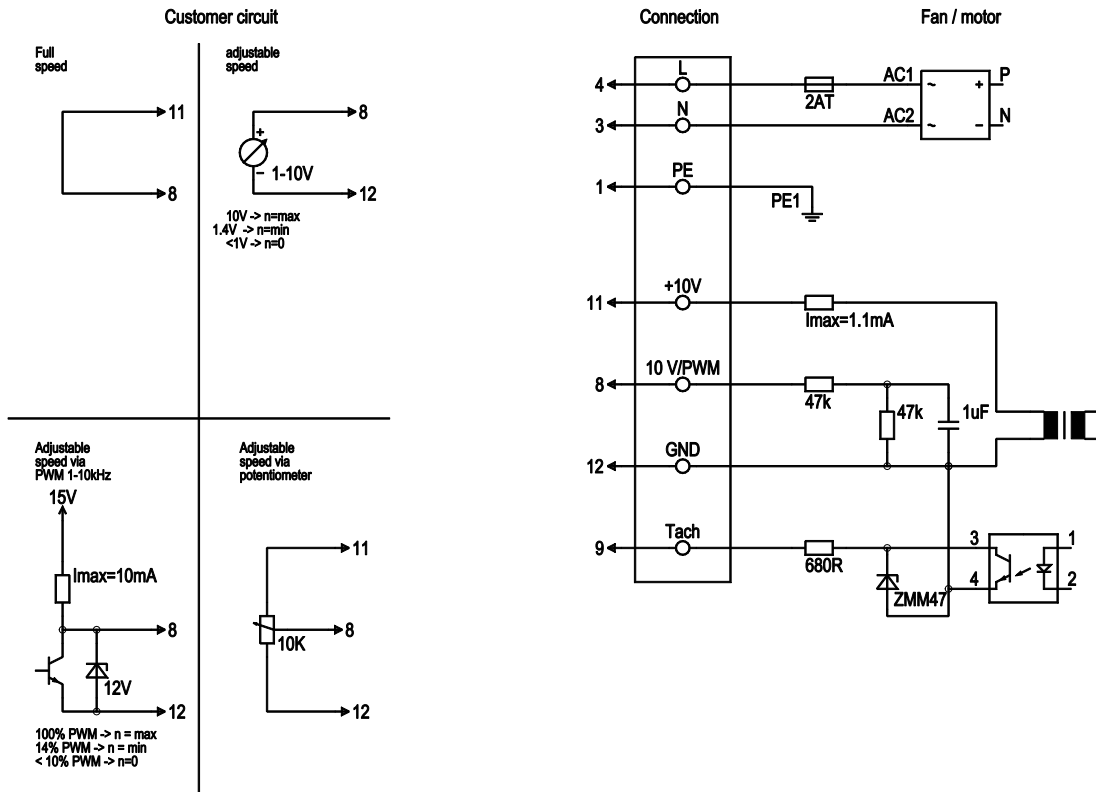

Line	No.	Signal	Colour	Function / assignment
	4	L	black	Power supply 230 VAC, 50-60 Hz, see type plate for voltage range
	3	N	blue	Neutral conductor
	1	PE	green/yellow	Protective earth
	8	0-10 V PWM	yellow	Control input 0 - 10 V or PWM, electrically isolated
	9	Tach	white	Tach output: open collector, 1 pulse per revolution, electrically isolated
	11	10V / max 1.1 mA	red	Voltage output 10 V / max. 1.1 mA, electrically isolated
	12	GND	blue	GND - Connection for control interface

Charts: Air flow 50 Hz

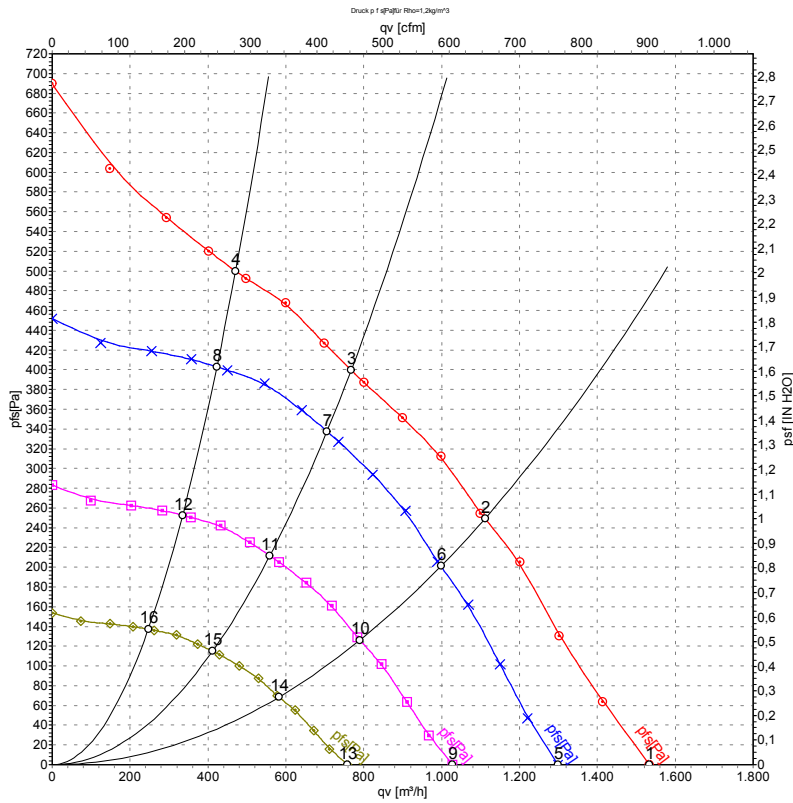

Measurement: LU-139844

Air performance measured as per ISO 5801 Installation category A. For detailed information on the measuring set-up, please contact ebmpapst. Suction-side noise levels: LwA measured as per ISO 13347 / LpA measured with 1m distance to fan axis. The values given are valid under the measuring conditions mentioned above and may vary according to the actual installation situation. With any deviation from the standard set-up, the specific values have to be checked and reviewed with the unit installed.

Measured values

	U	f	n	P _{ed}	I	qv	P _{fs}
	V	Hz	min ⁻¹	W	A	m ³ /h	Pa
1	230	50	2835	129	1.00	1535	0
2	230	50	2670	162	1.25	1110	250
3	230	50	2610	170	1.32	770	400
4	230	50	2675	160	1.24	470	500
5	230	50	2400	79	0.61	1300	0
6	230	50	2400	118	0.91	1000	201
7	230	50	2400	132	1.03	705	338
8	230	50	2400	116	0.90	425	403
9	230	50	1900	39	0.30	1030	0
10	230	50	1900	58	0.45	790	126
11	230	50	1900	65	0.51	560	212
12	230	50	1900	57	0.45	335	253
13	230	50	1400	16	0.12	760	0
14	230	50	1400	23	0.18	580	68
15	230	50	1400	26	0.20	410	115
16	230	50	1400	23	0.18	245	137

U = Supply voltage · f = Frequency · n = Speed · P_{ed} = Power input · I = Current draw · qv = Air flow · P_{fs} = Pressure increase

