

R3G250-AV29-B4

EC centrifugal fan

backward-curved, single-intake



R3G250-AV29-B4 ebmpapst Datasheet
sales@fansco.com
www.fansco.com

Limited partnership · Headquarters Mulfingen
Amtsgericht (court of registration) Stuttgart · HRA 590344

General partner Elektrobau Mulfingen GmbH · Headquarters Mulfingen
Amtsgericht (court of registration) Stuttgart · HRB 590142

Nominal data

Type	R3G250-AV29-B4	
Motor	M3G084-FA	
Phase		1~
Nominal voltage	VAC	230
Nominal voltage range	VAC	200 .. 277
Frequency	Hz	50/60
Method of obtaining data		ml
Speed (rpm)	min ⁻¹	3450
Power consumption	W	750
Current draw	A	3.3
Min. ambient temperature	°C	-25
Max. ambient temperature	°C	40

ml = Max. load · me = Max. efficiency · fa = Free air · cs = Customer specification · ce = Customer equipment
Subject to change

Data according to Commission Regulation (EU) 327/2011 (EN 17166)

		Actual	Req. 2015			
01 Overall efficiency η_{es}	%	59.1	50.2	09 Power consumption P_{ed}	kW	0.75
02 Measurement category		A		09 Air flow q_v	m ³ /h	1750
03 Efficiency category		Static		09 Pressure increase p_{fs}	Pa	833
04 Efficiency grade N		70.9	62	10 Speed (rpm) n	min ⁻¹	3445
05 Variable speed drive		Yes		11 Specific ratio*		1.01

Data obtained at optimum efficiency level.
The ErP data is determined using a motor-impeller combination in a standardized measurement setup.

* Specific ratio = $1 + p_{fs} / 100\,000\text{ Pa}$

LU-141280



Technical description

Weight	5.7 kg
Size	250 mm
Motor size	84
Rotor surface	Painted black
Electronics housing material	Die-cast aluminum, painted black
Impeller material	Sheet aluminum, painted black
Number of blades	6
Direction of rotation	Clockwise, viewed toward rotor
Degree of protection	IP54
Insulation class	"B"
Moisture (F) / Environmental (H) protection class	H2+S
Max. permitted ambient temp. for motor (transport/storage)	+80 °C
Min. permitted ambient temp. for motor (transport/storage)	-40 °C
Installation position	Shaft horizontal or rotor on bottom; rotor on top on request
Condensation drainage holes	On rotor side
Mode	S1
Motor bearing	Ball bearing
Technical features	<ul style="list-style-type: none"> - Output 10 VDC, max. 10 mA - Output 20 VDC, max. 50 mA - Output for slave 0-10 V - Selection of direction of rotation left/right - Input for sensor 0-10 V or 4-20 mA - Alarm relay - Power limiter - Motor current limitation - PFC, active - RS-485 MODBUS-RTU - Soft start - Control input 0-10 VDC / PWM - Control interface with SELV potential safely disconnected from the mains - Thermal overload protection for electronics/motor - Line undervoltage / phase failure detection
EMC immunity to interference	According to EN 61000-6-2 (industrial environment)
EMC circuit feedback	According to EN 61000-3-2/3
EMC interference emission	According to EN 61000-6-4 (industrial environment)
Touch current according to IEC 60990 (measuring circuit Fig. 4, TN system)	<= 3.5 mA
Electrical hookup	Terminal box
Motor protection	Thermal overload protector (TOP) internally connected
Protection class	I (with customer connection of protective earth)
Conformity with standards	EN 61800-5-1; CE
Approval	EAC

Product drawing

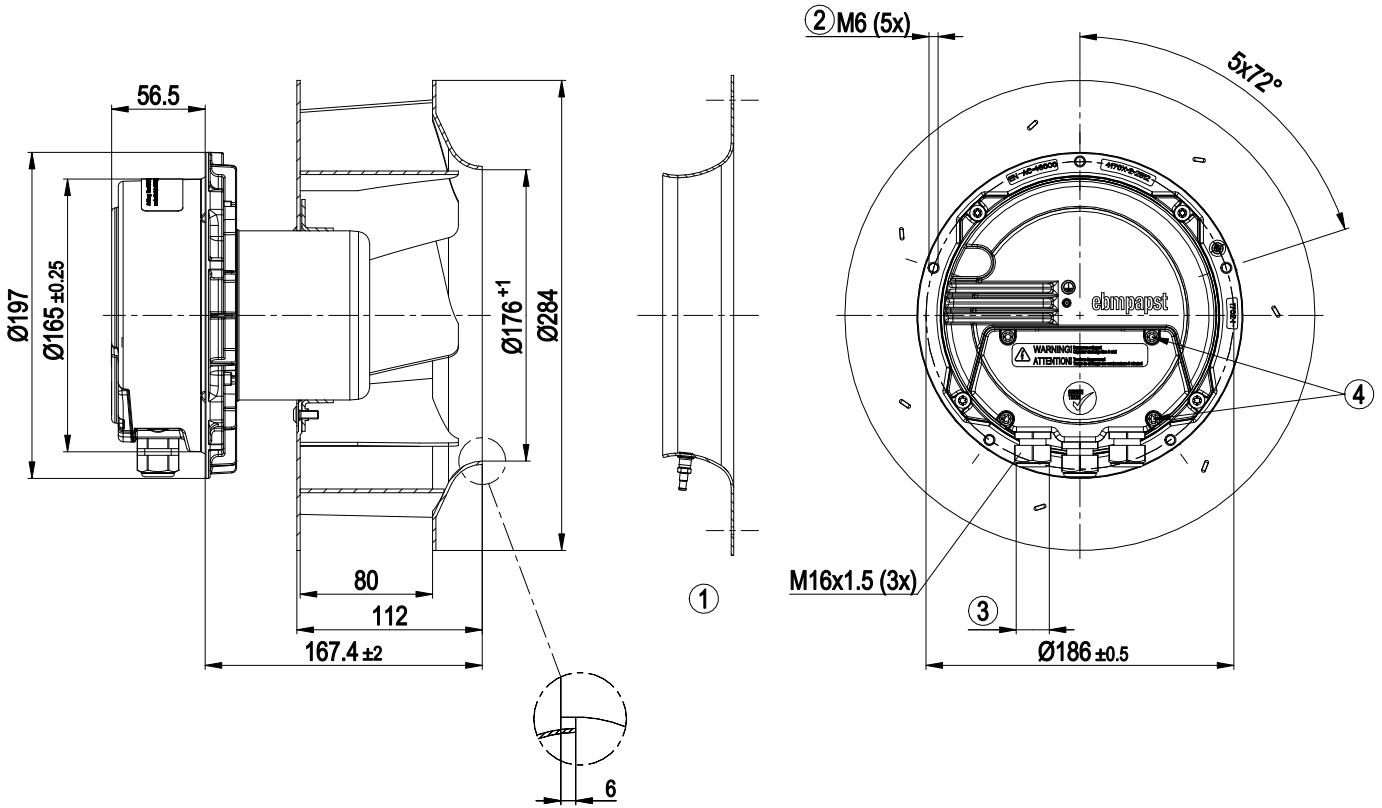

1	Accessory part: Inlet ring 25075-2-4013 with pressure tap (k-factor: 70) not included in scope of delivery
2	Max. clearance for screw 16 mm
3	Cable diameter min. 4 mm, max. 10 mm, tightening torque 2.5 ± 0.4 Nm
4	Tightening torque 3.5 ± 0.5 Nm



Accessory part

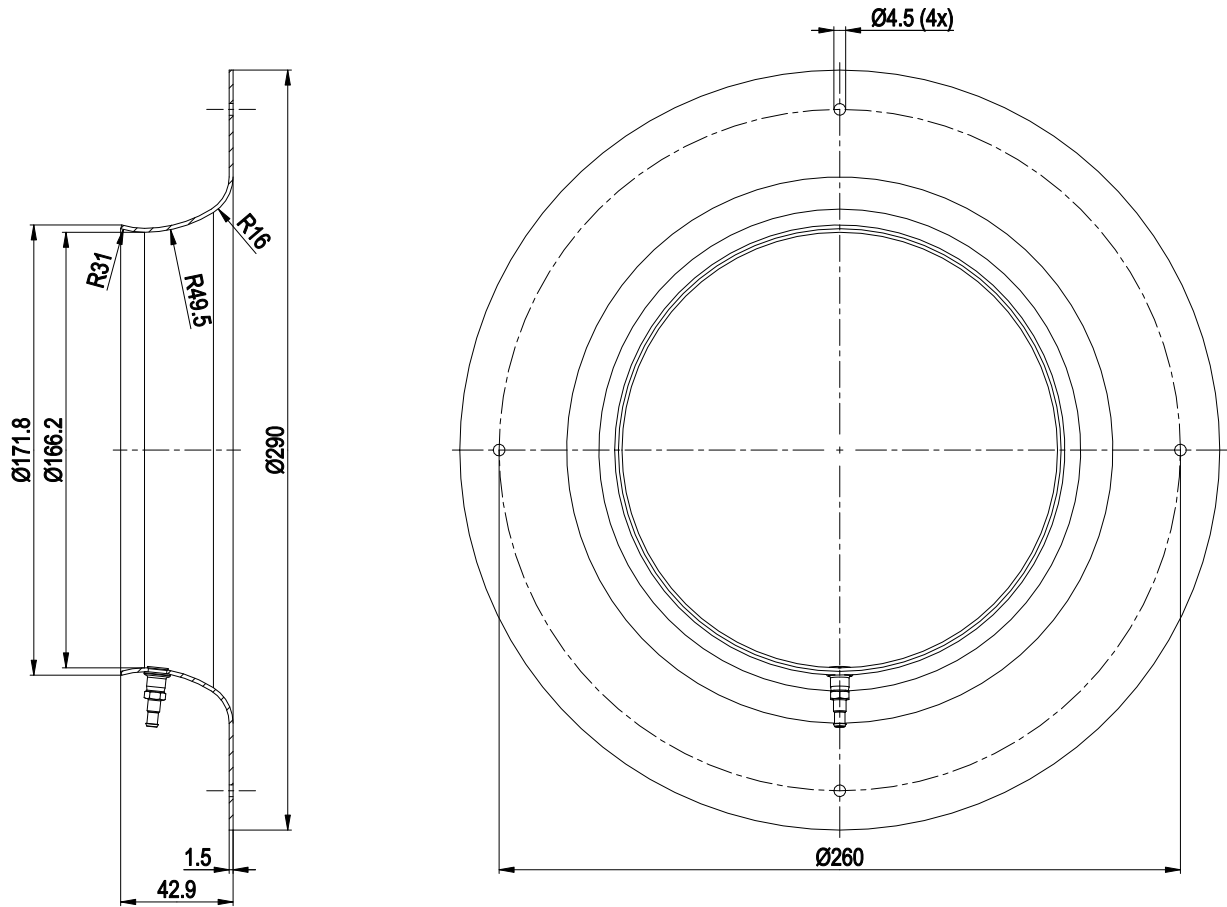

Inlet ring 25075-2-4013 with pressure tap not included in scope of delivery

Connection diagram

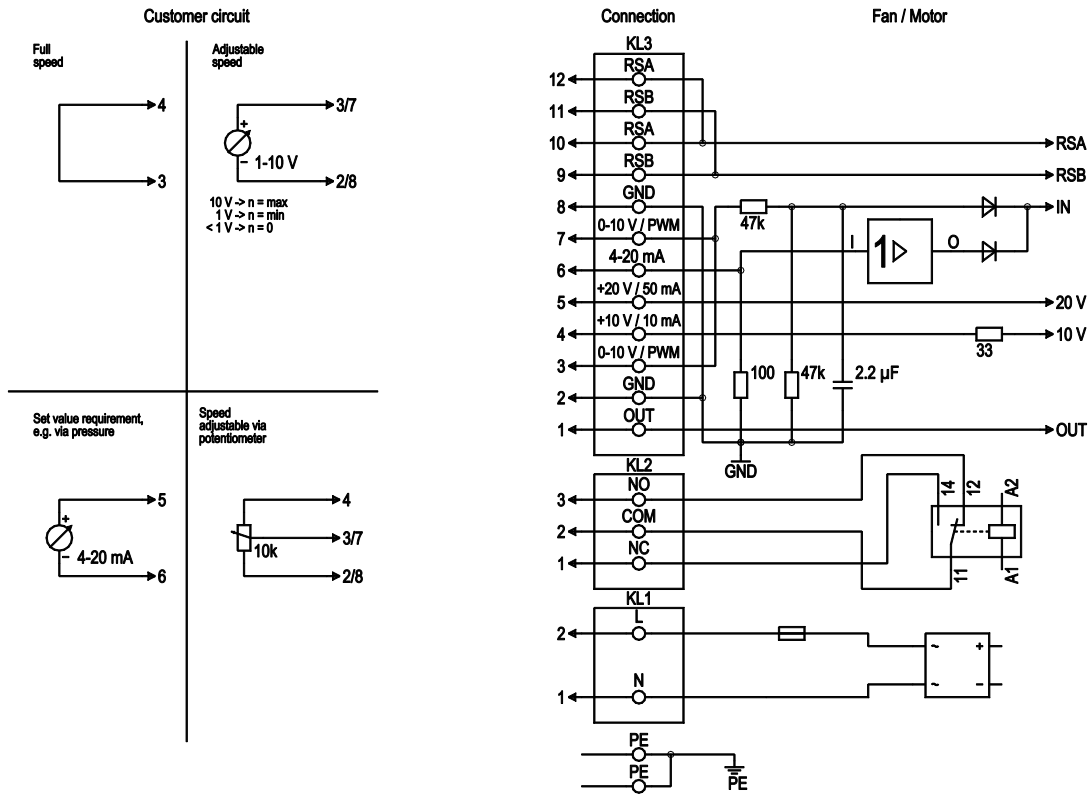

No.	Conn.	Designation	Function/assignment
PE	-	PE	Protective earth terminal
KL1	1, 2	N, L	Power supply 50/60 Hz
KL2	1	NC	Floating status contact, break for failure
KL2	2	COM	Floating status contact, changeover contact, common connection (2 A, max. 250 VAC, min. 10 mA, AC1)
KL2	3	NO	Floating status contact, make for failure
KL3	1	OUT	Analog output, 0-10 VDC, max. 3 mA, SELV output of current motor modulation level: 1 V corresponds to 10% modulation level. 10 V corresponds to 100% modulation level.
KL3	2, 8	GND	Reference ground for control interface, SELV
KL3	3, 7	0-10 V	Control/current sensor value input 0-10 VDC, impedance 100 kΩ, use only as alternative to 4-20 mA input, SELV
KL3	4	+10 V	Voltage output 10 VDC (+/- 3%), max. 10 mA, power supply for ext. devices (e.g. potentiometer), SELV
KL3	5	+20 V	Voltage output 20 VDC (+25%/-10%), max. 50 mA power supply for ext. devices (e.g. sensors), SELV
KL3	6	4-20 mA	Control/current sensor value input 4-20 mA, impedance 100 Ω, use only as alternative to 0-10 V input, SELV
KL3	9, 11	RSB	RS485 interface for MODBUS, RSB
KL3	10, 12	RSA	RS485 interface for MODBUS, RSA



Curves: Air performance 50 Hz

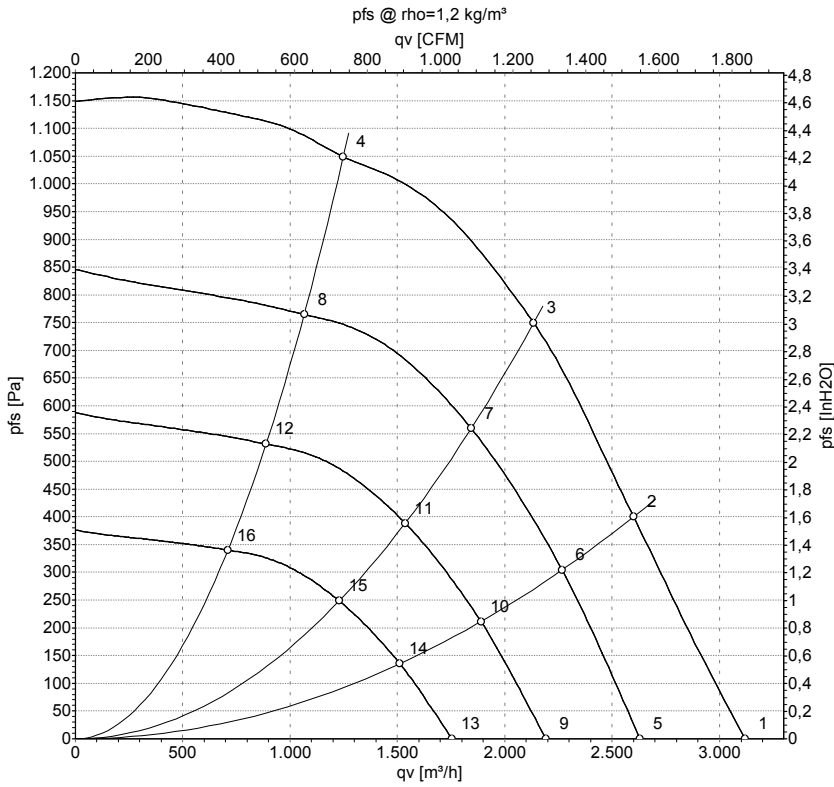

Measurement: LU-142908-1

Air performance measured according to ISO 5801 installation category A. For detailed information on the measurement setup, contact ebm-papst. Intake sound level: Sound power level according to ISO 13347 / sound pressure level measured at 1 m distance from fan axis. The values given are valid under the specified measuring conditions and may vary due to conditions of installation. For deviations from the standard configuration, the parameters have to be checked on the installed unit.

Measured values

	U	f	n	P _{ed}	I	LpA _{in}	LwA _{in}	LwA _{out}	q _v	P _{fs}	q _v	P _{fs}
	V	Hz	min ⁻¹	W	A	dB(A)	dB(A)	dB(A)	m ³ /h	Pa	cfm	in. wg
1	230	50	3450	581	2.58	77	85	91	3120	0	1835	0.00
2	230	50	3450	673	2.98	74	82	88	2600	400	1530	1.61
3	230	50	3450	750	3.30	71	79	85	2135	750	1255	3.01
4	230	50	3450	691	3.07	79	86	87	1250	1050	735	4.22
5	230	50	3000	349	1.55	73	80	87	2630	0	1550	0.00
6	230	50	3000	446	1.97	71	78	84	2265	304	1335	1.22
7	230	50	3000	486	2.16	68	75	81	1845	559	1085	2.24
8	230	50	3000	432	1.92	75	82	83	1065	765	625	3.07
9	230	50	2500	202	0.90	68	76	82	2195	0	1290	0.00
10	230	50	2500	258	1.14	66	74	80	1890	211	1110	0.85
11	230	50	2500	281	1.25	63	71	76	1535	388	905	1.56
12	230	50	2500	250	1.11	70	77	78	890	531	525	2.13
13	230	50	2000	103	0.46	63	70	76	1755	0	1030	0.00
14	230	50	2000	132	0.59	60	68	74	1510	135	890	0.54
15	230	50	2000	144	0.64	57	65	71	1230	249	725	1.00
16	230	50	2000	128	0.57	64	72	72	710	340	420	1.36

U = Voltage · f = Frequency · n = Speed (rpm) · P_{ed} = Power consumption · I = Current draw · LpA_{in} = Sound pressure level intake side · LwA_{in} = Sound power level intake side
 LwA_{out} = Sound power level outlet side · q_v = Air flow · P_{fs} = Pressure increase

