

R3G250-AM50-11 ebmpapst Datasheet
 sales@fansco.com
 www.fansco.com

Limited partnership · Headquarters Muldingen
 Amtsgericht (court of registration) Stuttgart · HRA 590344

General partner Elektrobau Muldingen GmbH · Headquarters Muldingen
 Amtsgericht (court of registration) Stuttgart · HRB 590142

Nominal data

Type	R3G250-AM50-11	
Motor	M3G074-CF	
Phase		1~
Nominal voltage	VAC	230
Nominal voltage range	VAC	200 .. 277
Frequency	Hz	50/60
Method of obtaining data		ml
Speed (rpm)	min ⁻¹	2420
Power consumption	W	173
Current draw	A	1.3
Min. ambient temperature	°C	-25
Max. ambient temperature	°C	50

ml = Max. load · me = Max. efficiency · fa = Free air · cs = Customer specification · ce = Customer equipment
 Subject to change

Data according to Commission Regulation (EU) 327/2011

		Actual	Req. 2015			
01 Overall efficiency η_{es}	%	47	43.4	09 Power consumption P_{ed}	kW	0.17
02 Measurement category		A		09 Air flow q_v	m ³ /h	865
03 Efficiency category		Static		09 Pressure increase p_{fs}	Pa	301
04 Efficiency grade N		65.6	62	10 Speed (rpm) n	min ⁻¹	2380
05 Variable speed drive		Yes		11 Specific ratio [*]		1.00

Data obtained at optimum efficiency level.

The ErP data is determined using a motor-impeller combination in a standardized measurement setup.

^{*} Specific ratio = $1 + p_{fs} / 100\,000\text{ Pa}$

LU-73336



Technical description

Weight	3 kg
Fan size	250 mm
Rotor surface	Painted black
Impeller material	Sheet steel, galvanized
Number of blades	11
Direction of rotation	Clockwise, viewed toward rotor
Degree of protection	IP44; installation- and position-dependent as per EN 60034-5
Insulation class	"B"
Moisture (F) / Environmental (H) protection class	F3-1
Max. permitted ambient temp. for motor (transport/storage)	+ 80 °C
Min. permitted ambient temp. for motor (transport/storage)	- 40 °C
Installation position	Shaft horizontal or rotor on bottom; rotor on top on request
Condensation drainage holes	On rotor side
Mode	S1
Motor bearing	Ball bearing
Technical features	<ul style="list-style-type: none"> - Output 10 VDC, max. 1.1 mA - Tach output - Motor current limitation - Soft start - Control input 0-10 VDC / PWM - Thermal overload protection for electronics/motor
EMC immunity to interference	According to EN 61000-6-2 (industrial environment)
EMC circuit feedback	According to EN 61000-3-2/3
EMC interference emission	According to EN 61000-6-3 (household environment)
Touch current according to IEC 60990 (measuring circuit Fig. 4, TN system)	<= 3.5 mA
Motor protection	Thermal overload protector (TOP) internally connected
With cable	Variable
Protection class	I (with customer connection of protective earth)
Conformity with standards	EN 60335-1; CE
Approval	UL 2111; CSA C22.2 No. 77

Product drawing

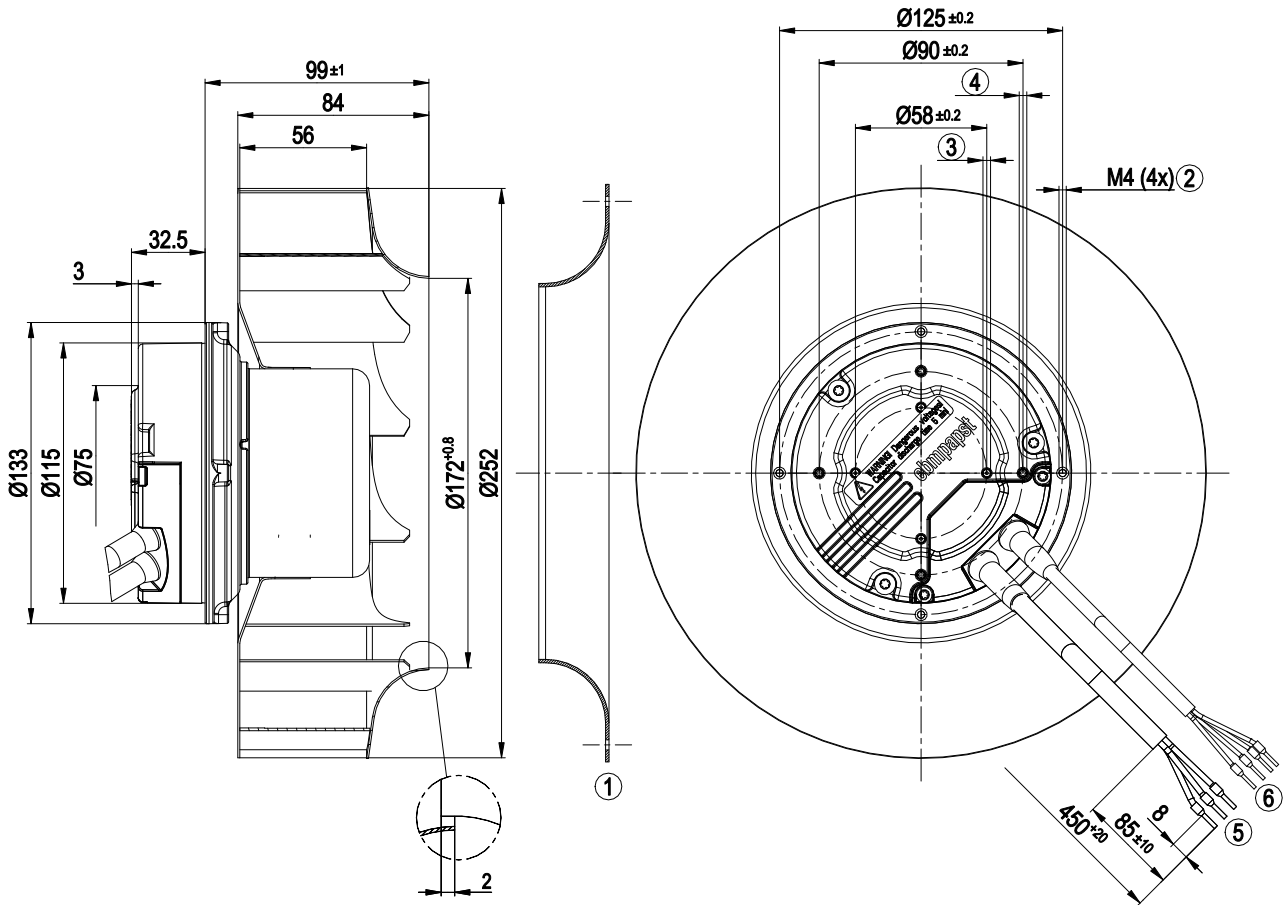

1	Accessory part: Inlet ring 96359-2-4013 not included in scope of delivery, other inlet rings on request
2	Clearance for screw 8-10 mm; gluing the screws is recommended
3	Tapping hole ready for self-tapping M4 screw, max. clearance for screw 6 mm
4	Tapping hole ready for self-tapping M4 screw, max. clearance for screw 8 mm
5	Cable AWG18, 3x crimped ferrules
6	Cable AWG22, 4x crimped ferrules



Accessory part

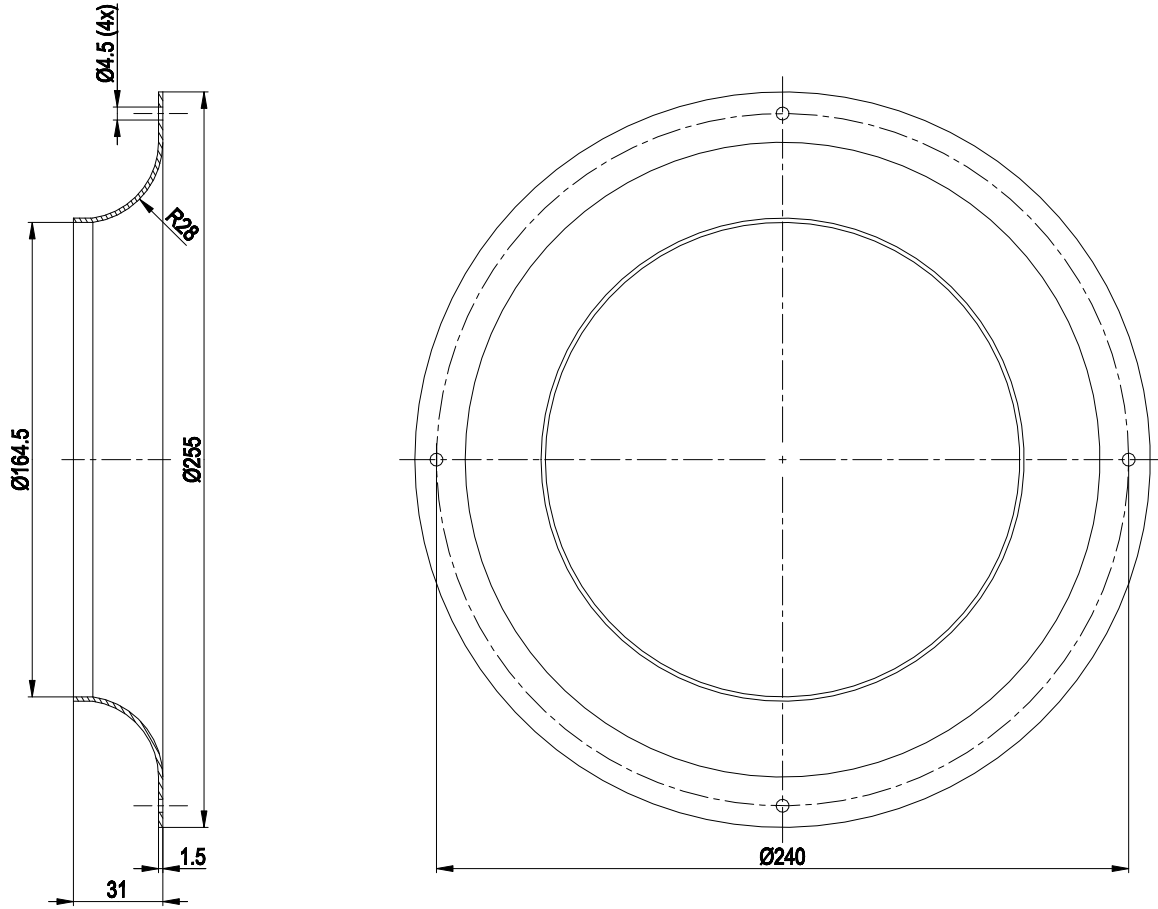

Accessory part: inlet ring 96359-2-4013 not included in scope of delivery



Connection diagram

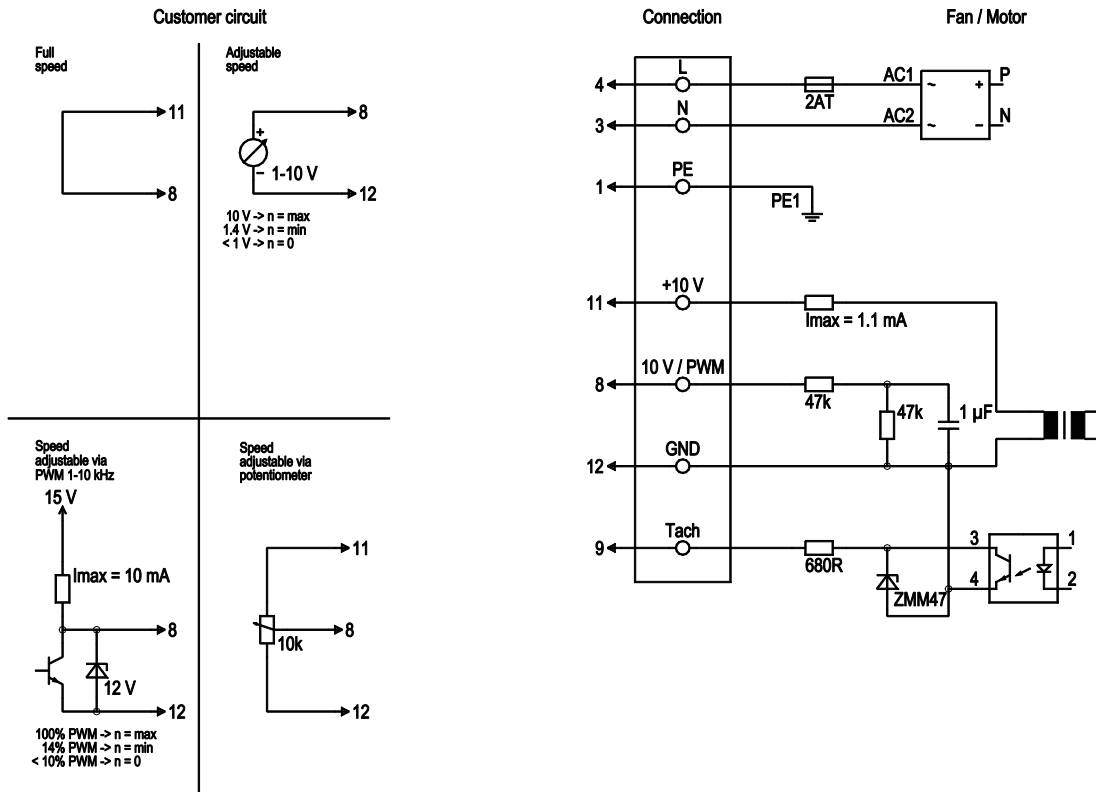

No.	Conn.	Designation	Color	Function/assignment
	4	L	black	Power supply 230 VAC, 50-60 Hz, see nameplate for voltage range
	3	N	blue	Neutral conductor
	1	PE	green/yellow	Protective earth
	8	0-10 V PWM	yellow	Control input 0-10 V or PWM, electrically isolated
	9	Tach	white	Tach output: open collector, 1 pulse per revolution, electrically isolated
	11	10V / max 1.1 mA	red	Voltage output 10 V/max. 1.1 mA, electrically isolated
	12	GND	blue	GND connection for control interface



Curves: Air performance 50 Hz

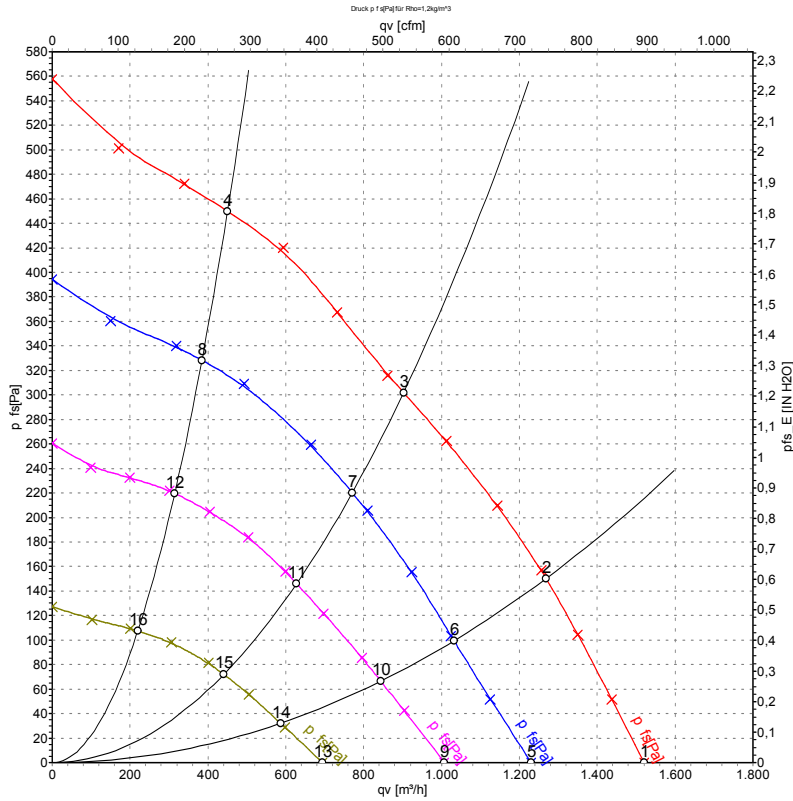

Measurement: LU-73336-1
Measurement: LU-67423-1
Measurement: LU-67424-1
Measurement: LU-67425-1

Air performance measured according to ISO 5801 installation category A. For detailed information on the measurement setup, contact ebmpapst. Intake sound level: Sound power level according to ISO 13347 / sound pressure level measured at 1 m distance from fan axis. The values given are valid under the specified measuring conditions and may vary due to conditions of installation. For deviations from the standard configuration, the parameters have to be checked on the installed unit.

Measured values

	U	f	n	P _{ed}	I	q _v	P _{st}	q _v	P _{st}
	V	Hz	min ⁻¹	W	A	m ³ /h	Pa	cfm	inH ₂ O
1	230	50	2510	140	1.00	1520	0	895	0.00
2	230	50	2465	157	1.17	1270	150	745	0.60
3	230	50	2420	173	1.30	900	300	530	1.20
4	230	50	2495	152	1.14	450	450	265	1.81
5	230	50	2170	99	0.74	1230	0	725	0.00
6	230	50	2150	108	0.81	1030	100	605	0.40
7	230	50	2140	118	0.88	770	220	455	0.88
8	230	50	2155	103	0.78	385	328	225	1.32
9	230	50	1770	55	0.42	1005	0	595	0.00
10	230	50	1755	63	0.48	845	66	495	0.26
11	230	50	1750	70	0.53	630	146	370	0.59
12	230	50	1755	62	0.47	315	220	185	0.88
13	230	50	1235	26	0.21	695	0	410	0.00
14	230	50	1240	30	0.23	585	32	345	0.13
15	230	50	1225	31	0.25	440	72	260	0.29
16	230	50	1230	27	0.22	220	108	130	0.43

U = Power supply · f = Frequency · n = Speed (rpm) · P_{ed} = Power consumption · I = Current draw · q_v = Air flow · P_{st} = Pressure increase

