

R3G250-AK41-78

EC centrifugal fan

backward curved, single inlet



R3G250-AK41-78 ebmpapst Datasheet

sales@fansco.com

www.fansco.com

Limited partnership · Headquarters Mulfingen
County court Stuttgart · HRA 590344

General partner Elektrobau Mulfingen GmbH · Headquarters Mulfingen
County court Stuttgart · HRB 590142



Nominal data

Type	R3G250-AK41-78	
Motor	M3G084-DF	
Phase		1~
Nominal voltage	VAC	230
Nominal voltage range	VAC	200 .. 277
Frequency	Hz	50/60
Type of data definition		ml
Speed	min ⁻¹	3390
Power input	W	490
Current draw	A	3.1
Min. ambient temperature	°C	-25
Max. ambient temperature	°C	60

ml = max. load · me = max. efficiency · fa = running at free air · cs = customer specs · cu = customer unit
Subject to alterations

Data according to ErP directive

Installation category	A
Efficiency category	Static
Variable speed drive	Yes
Specific ratio*	1.01

* Specific ratio = $1 + p_{fs} / 100\,000\text{ Pa}$

	Actual	Request 2013	Request 2015
Overall efficiency η_{es}	48.2	44.2	48.2
Efficiency grade N	62	58	62
Power input P_{ed}	kW	0.48	
Air flow q_v	m ³ /h	1235	
Pressure increase p_{fs}	Pa	600	
Speed n	min ⁻¹	3390	

Data established at point of optimum efficiency



Technical features

Mass	4.48 kg
Size	250 mm
Surface of rotor	Coated in black
Material of electronics housing	Die-cast aluminium
Material of impeller	Sheet steel, hot-dip galvanised
Number of blades	11
Direction of rotation	Clockwise, seen on rotor
Type of protection	IP 20
Insulation class	"B"
Humidity class	F3-1
Max. permissible ambient motor temp. (transp./ storage)	+80 °C
Min. permissible ambient motor temp. (transp./storage)	-40 °C
Mounting position	Shaft horizontal or rotor on top; rotor on bottom on request
Condensate discharge holes	None, open rotor
Operation mode	S1
Motor bearing	Ball bearing
Technical features	<ul style="list-style-type: none"> - Control input 0-10 VDC / PWM - Output 10 VDC, max. 1.1 mA - Tach output - Over-temperature protected electronics / motor - Line undervoltage detection - Motor current limit - Soft start
EMC interference immunity	Acc. to EN 61000-6-2
EMC harmonics	Acc. to EN 61000-3-2/3
EMC interference emission	Acc. to EN 61000-6-3
Touch current acc. IEC 60990 (measuring network Fig. 4, TN system)	<= 3.5 mA
Motor protection	Thermal overload protector (TOP) wired internally
Cable exit	Variable
Protection class	I (if protective earth is connected by customer)
Product conforming to standard	EN 61800-5-1; CE
Approval	UL 2111; CCC; CSA C22.2 Nr.77

EC centrifugal fan

backward curved, single inlet

Product drawing

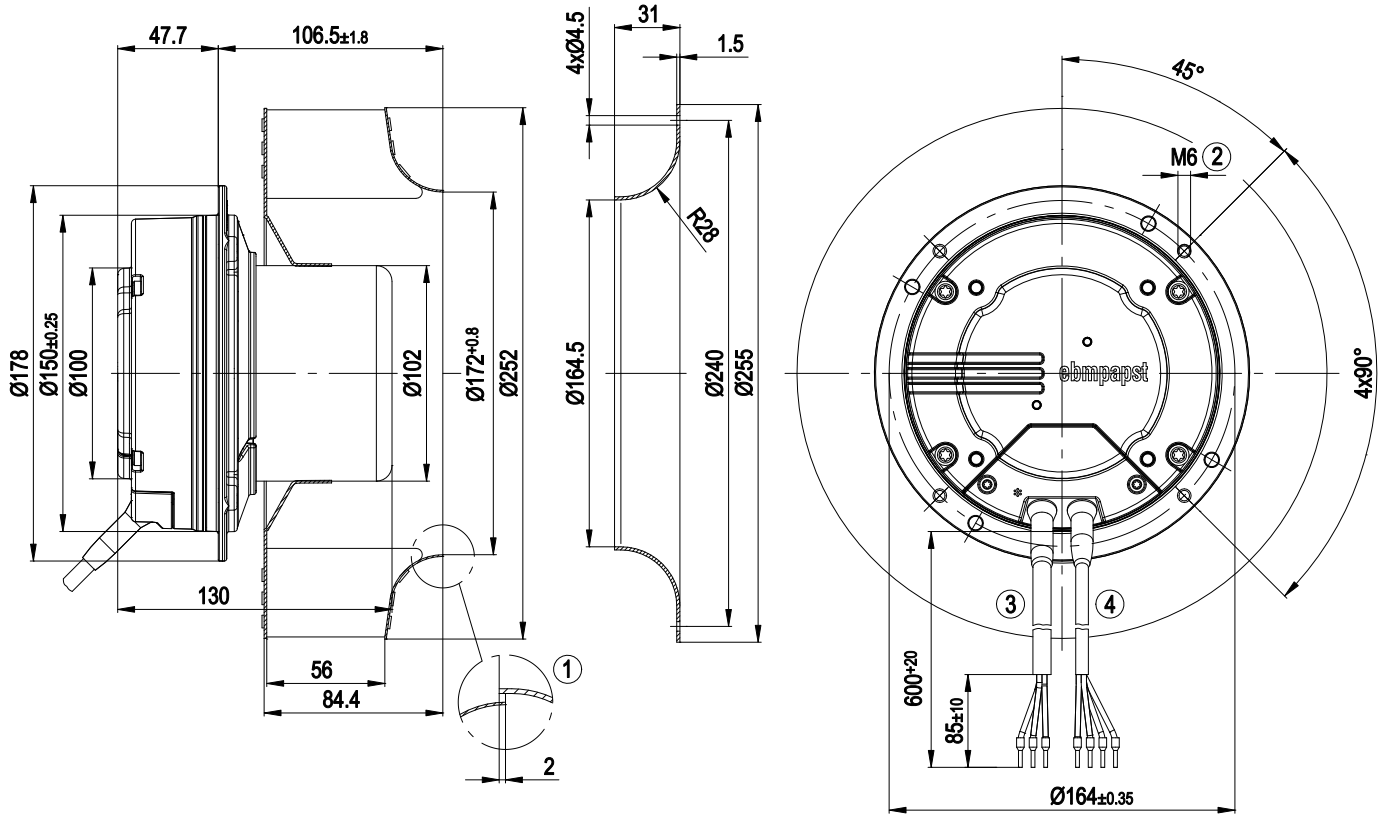

1	Accessory part: inlet nozzle 96359-2-4013 not included in the standard scope of delivery; other inlet nozzles on request
2	Depth of screw 8-10 mm
3	Connection line AWG18, 3 x crimped core-end sleeves
4	Connection line AWG22, 4 x crimped core-end sleeves



Connection screen

Customer circuit

Notes on various control possibilities and their applications

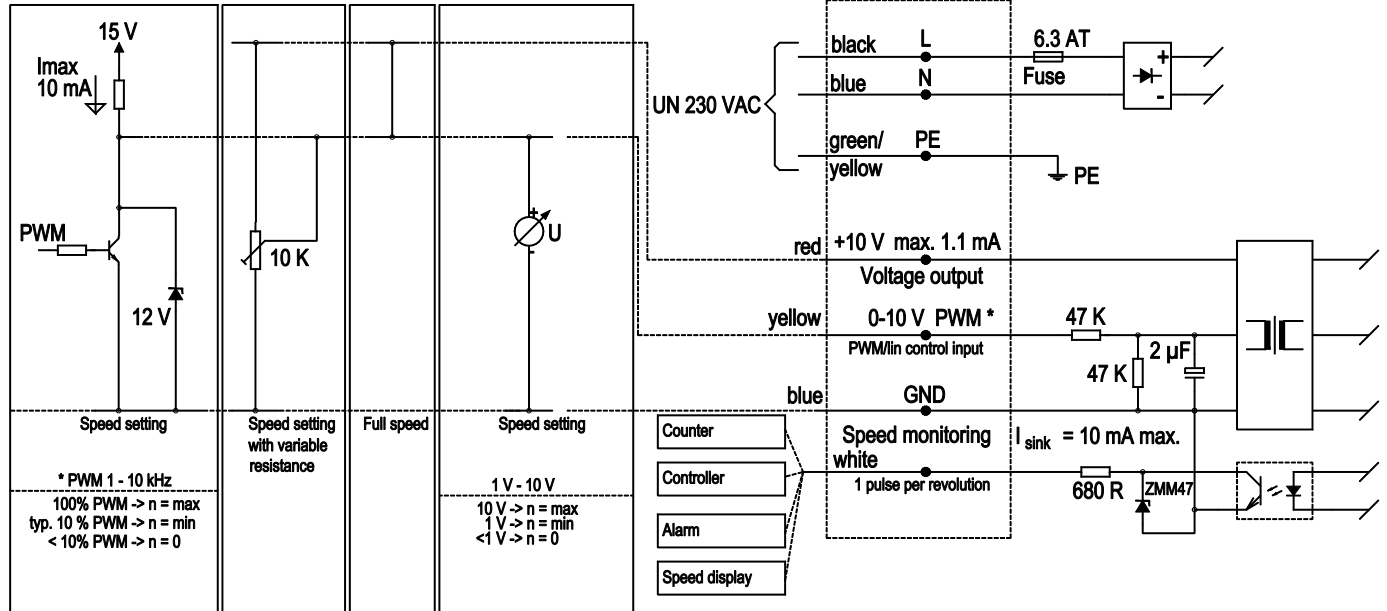

Charts: Air flow 50 Hz

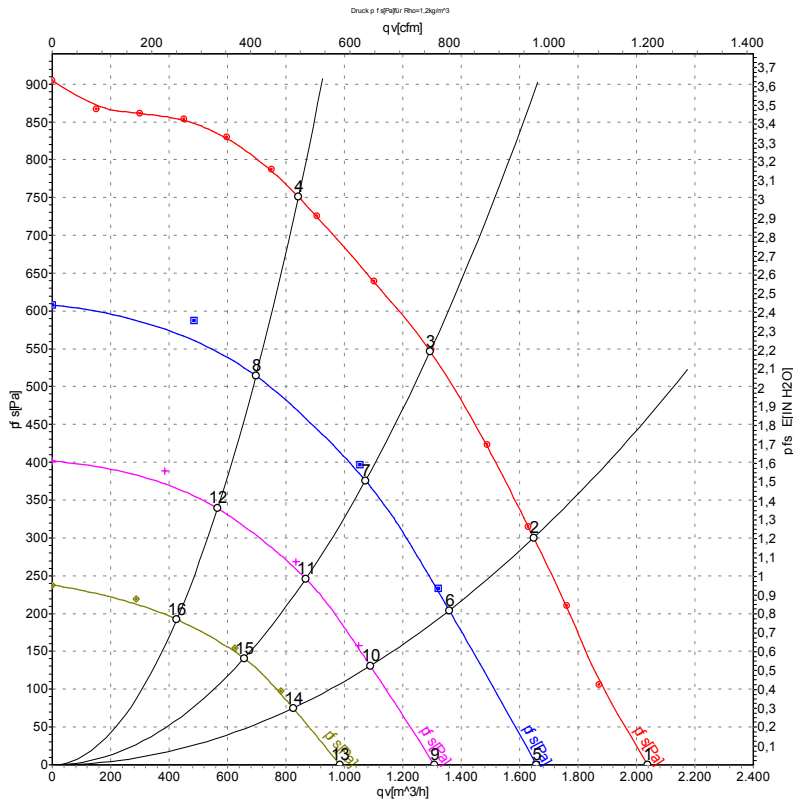

Measurement: LU-111414
 Measurement: LU-111481
 Measurement: LU-111482
 Measurement: LU-111483

Air performance measured as per ISO 5801 Installation category A. For detailed information on the measuring set-up, please contact ebmpapst. Suction-side noise levels: L_{wA} measured as per ISO 13347 / L_{pA} measured with 1m distance to fan axis. The values given are valid under the measuring conditions mentioned above and may vary according to the actual installation situation. With any deviation from the standard set-up, the specific values have to be checked and reviewed with the unit installed.

Measured values

	U	f	n	P _{ed}	I	L _{pA_{in}}	L _{wA_{in}}	qv	p _{fs}
	V	Hz	min ⁻¹	W	A	dB(A)	dB(A)	m ³ /h	Pa
1	230	50	3390	324	2.11	77	84	2040	0
2	230	50	3390	412	2.66	75	82	1650	300
3	230	50	3390	490	3.10	74	81	1295	550
4	230	50	3390	430	2.78	76	83	840	750
5	230	50	2800	180	1.20	74	81	1660	0
6	230	50	2800	230	1.52	70	78	1360	207
7	230	50	2800	264	1.71	68	76	1070	386
8	230	50	2800	225	1.48	70	78	695	516
9	230	50	2250	100	0.71	70	77	1310	0
10	230	50	2250	129	0.89	66	73	1090	134
11	230	50	2250	137	0.94	62	69	870	251
12	230	50	2250	124	0.86	63	71	565	340
13	230	50	1700	48	0.37	65	72	985	0
14	230	50	1700	55	0.42	60	67	825	77
15	230	50	1700	63	0.47	55	63	655	143
16	230	50	1700	56	0.42	56	64	425	193

U = Supply voltage · f = Frequency · n = Speed · P_{ed} = Power input · I = Current draw · L_{pA_{in}} = Sound pressure level inlet side · L_{wA_{in}} = Sound power level inlet side · qv = Air flow
 p_{fs} = Pressure increase

