

R3G250-AK41-76

# EC centrifugal fan

backward-curved, single-intake



R3G250-AK41-76 ebmpapst Datasheet

sales@fansco.com

www.fansco.com

## Nominal data

Type	R3G250-AK41-76	
Motor	M3G084-DF	
Phase		1~
Nominal voltage	VAC	230
Nominal voltage range	VAC	200 .. 277
Frequency	Hz	50/60
Method of obtaining data		ml
Speed (rpm)	min <sup>-1</sup>	3390
Power consumption	W	490
Current draw	A	3.1
Min. ambient temperature	°C	-25
Max. ambient temperature	°C	60

ml = Max. load · me = Max. efficiency · fa = Free air · cs = Customer specification · ce = Customer equipment  
Subject to change

## Data according to Commission Regulation (EU) 327/2011 (EN 17166)

		Actual	Req. 2015
01 Overall efficiency $\eta_{es}$	%	48.6	48
02 Measurement category		A	
03 Efficiency category		Static	
04 Efficiency grade N		62.6	62
05 Variable speed drive		Yes	

Data obtained at optimum efficiency level.  
The ErP data is determined using a motor-impeller combination in a standardized measurement setup.

09 Power consumption $P_{ed}$	kW	0.46
09 Air flow $q_v$	m <sup>3</sup> /h	1055
09 Pressure increase $p_{fs}$	Pa	689
10 Speed (rpm) $n$	min <sup>-1</sup>	3395
11 Specific ratio*		1.01

\* Specific ratio =  $1 + p_{fs} / 100\,000\text{ Pa}$

LU-105835



## Technical description

Weight	4.5 kg
Size	250 mm
Motor size	84
Rotor surface	Painted black
Electronics housing material	Die-cast aluminum
Impeller material	Sheet steel, hot-dip galvanized
Number of blades	11
Direction of rotation	Clockwise, viewed toward rotor
Degree of protection	IP20
Insulation class	"B"
Moisture (F) / Environmental (H) protection class	H1
Max. permitted ambient temp. for motor (transport/storage)	+80 °C
Min. permitted ambient temp. for motor (transport/storage)	-40 °C
Installation position	Any
Condensation drainage holes	None, open rotor
Mode	S1
Motor bearing	Ball bearing
Technical features	<ul style="list-style-type: none"> <li>- Control input 0-10 VDC / PWM</li> <li>- Output 10 VDC, max. 1.1 mA</li> <li>- Thermal overload protection for electronics/motor</li> <li>- Alarm relay</li> <li>- Line undervoltage detection</li> <li>- Motor current limitation</li> <li>- Soft start</li> </ul>
EMC immunity to interference	According to EN 61000-6-2 (industrial environment)
EMC circuit feedback	According to EN 61000-3-2/3
EMC interference emission	According to EN 61000-6-3 (household environment)
Touch current according to IEC 60990 (measuring circuit Fig. 4, TN system)	<= 3.5 mA
Motor protection	Thermal overload protector (TOP) internally connected
With cable	Variable
Protection class	I (with customer connection of protective earth)
Conformity with standards	EN 61800-5-1; CE
Approval	VDE; CSA C22.2 No. 77 + CAN/CSA-E60730-1; UL 1004-3 + 60730-1

Product drawing

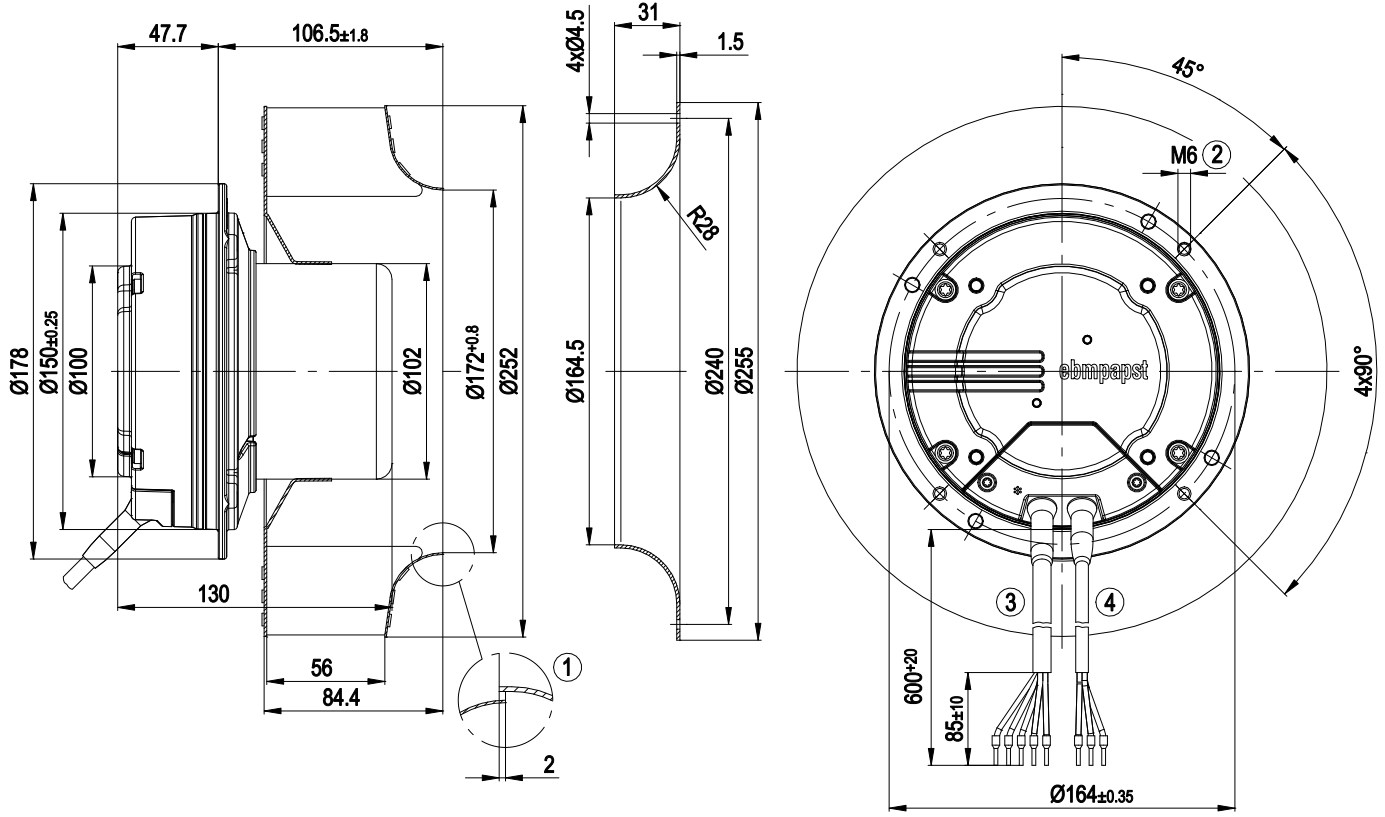

1	Accessory part: Inlet ring 96359-2-4013 not included in scope of delivery, other inlet rings on request
2	Clearance for screw 8-10 mm
3	Cable AWG18, 5 x crimped ferrules
4	Cable AWG22, 3 x crimped ferrules



# EC centrifugal fan

backward-curved, single-intake

## Connection diagram

Customer circuit

Application notes for various control options

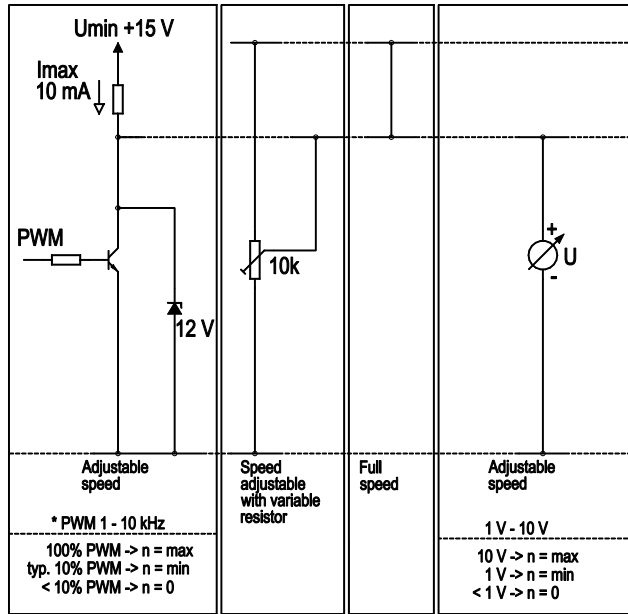

Connection

Fan / Motor

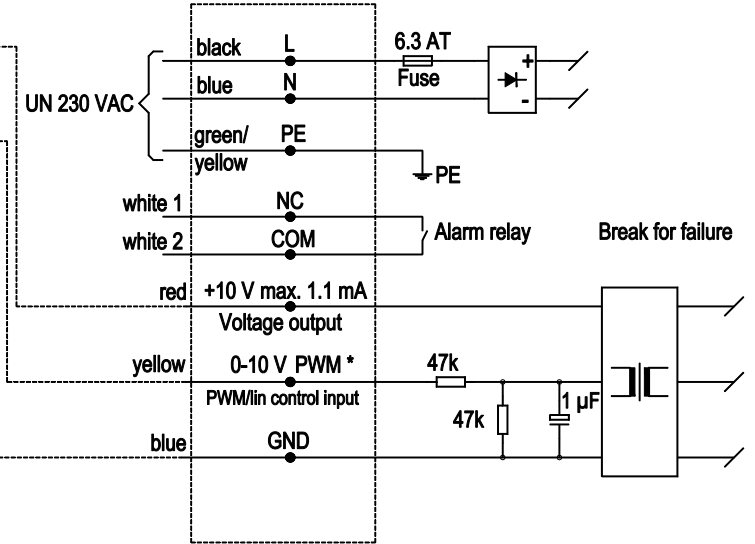

## Curves: Air performance 50 Hz

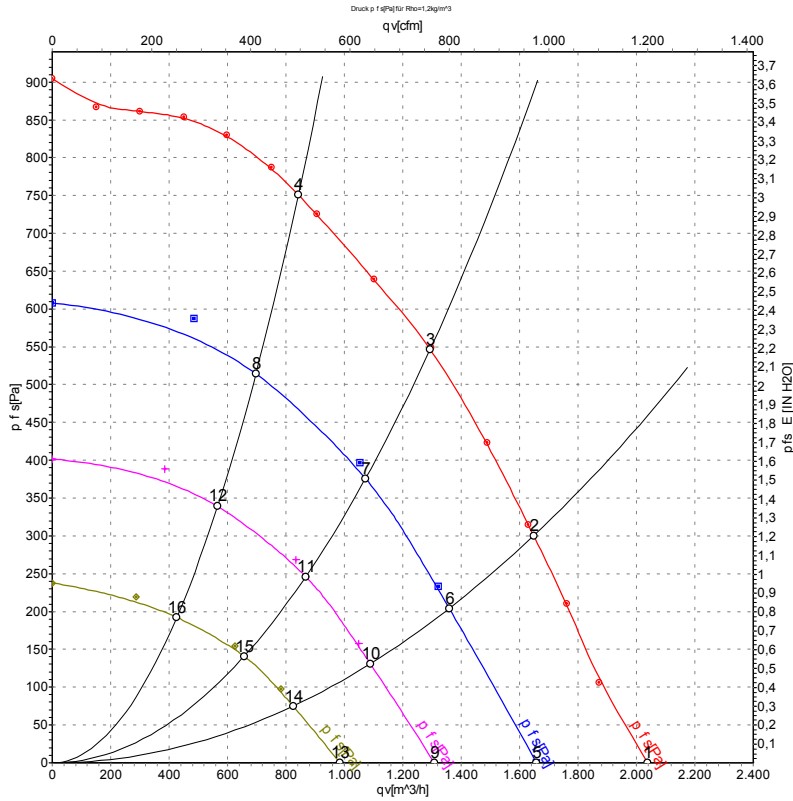

Measurement: LU-111414-1  
 Measurement: LU-111481-1  
 Measurement: LU-111482-1  
 Measurement: LU-111483-1

Air performance measured according to ISO 5801 installation category A. For detailed information on the measurement setup, contact ebmpapst. Intake sound level: Sound power level according to ISO 13347 / sound pressure level measured at 1 m distance from fan axis. The values given are valid under the specified measuring conditions and may vary due to conditions of installation. For deviations from the standard configuration, the parameters have to be checked on the installed unit.

## Measured values

	U	f	n	P <sub>ed</sub>	I	LpA <sub>in</sub>	LwA <sub>in</sub>	q <sub>v</sub>	p <sub>s</sub>	q <sub>v</sub>	p <sub>s</sub>
	V	Hz	min <sup>-1</sup>	W	A	dB(A)	dB(A)	m <sup>3</sup> /h	Pa	cfm	in. wg
1	230	50	3390	324	2.11	77	84	2040	0	1200	0.00
2	230	50	3390	412	2.66	75	82	1650	300	970	1.20
3	230	50	3390	490	3.10	74	81	1295	550	760	2.21
4	230	50	3390	430	2.78	76	83	840	750	495	3.01
5	230	50	2800	180	1.20	74	81	1660	0	975	0.00
6	230	50	2800	230	1.52	70	78	1360	207	800	0.83
7	230	50	2800	264	1.71	68	76	1070	386	630	1.55
8	230	50	2800	225	1.48	70	78	695	516	410	2.07
9	230	50	2250	100	0.71	70	77	1310	0	770	0.00
10	230	50	2250	129	0.89	66	73	1090	134	640	0.54
11	230	50	2250	137	0.94	62	69	870	251	510	1.01
12	230	50	2250	124	0.86	63	71	565	340	335	1.36
13	230	50	1700	48	0.37	65	72	985	0	580	0.00
14	230	50	1700	55	0.42	60	67	825	77	485	0.31
15	230	50	1700	63	0.47	55	63	655	143	385	0.57
16	230	50	1700	56	0.42	56	64	425	193	250	0.77

U = Voltage · f = Frequency · n = Speed (rpm) · P<sub>ed</sub> = Power consumption · I = Current draw · LpA<sub>in</sub> = Sound pressure level intake side · LwA<sub>in</sub> = Sound power level intake side  
 q<sub>v</sub> = Air flow · p<sub>s</sub> = Pressure increase

