

EC centrifugal fan

backward-curved, single-intake

for rail applications

R3G250-AK33-92 ebmpapst Datasheet

sales@fansco.com

www.fansco.com

Limited partnership · Headquarters Muldingen

Amtsgericht (court of registration) Stuttgart · HRA 590344

General partner Elektrobau Muldingen GmbH · Headquarters Muldingen

Amtsgericht (court of registration) Stuttgart · HRB 590142

Nominal data

Type	R3G250-AK33-92	
Motor	M3G084-DF	
Nominal voltage	VDC	110
Nominal voltage range	VDC	77 .. 145
Method of obtaining data		ml
Speed (rpm)	min ⁻¹	2700
Power consumption	W	250
Current draw	A	2.2
Min. ambient temperature	°C	-25
Max. ambient temperature	°C	60

ml = Max. load · me = Max. efficiency · fa = Free air · cs = Customer specification · ce = Customer equipment
Subject to change



EC centrifugal fan

backward-curved, single-intake
for rail applications

Technical description

Weight	4.8 kg
Fan size	250 mm
Rotor surface	Painted black
Electronics housing material	Die-cast aluminum
Impeller material	Sheet steel, hot-dip galvanized
Number of blades	11
Direction of rotation	Clockwise, viewed toward rotor
Degree of protection	IP54
Insulation class	"B"
Moisture (F) / Environmental (H) protection class	F3-1
Max. permitted ambient temp. for motor (transport/storage)	+80 °C
Min. permitted ambient temp. for motor (transport/storage)	-40 °C
Installation position	Shaft horizontal or rotor on top; rotor on bottom on request
Condensation drainage holes	None
Mode	S1
Motor bearing	Ball bearing
Technical features	<ul style="list-style-type: none"> - Output 10 VDC, max. 1.1 mA - Alarm relay - Motor current limitation - Soft start - Control input 0-10 VDC / PWM - Control interface with SELV potential safely disconnected from the mains - Thermal overload protection for electronics/motor - Line undervoltage detection
EMC immunity to interference	According to EN 61000-6-2 (industrial environment)
EMC interference emission	According to EN 61000-6-4 (industrial environment)
Motor protection	Thermal overload protector (TOP) internally connected
With cable	Variable
Protection class	I (with customer connection of protective earth)
Conformity with standards	EN 61800-5-1
Approval	CCC; EAC



EC centrifugal fan

backward-curved, single-intake
for rail applications

Connection diagram

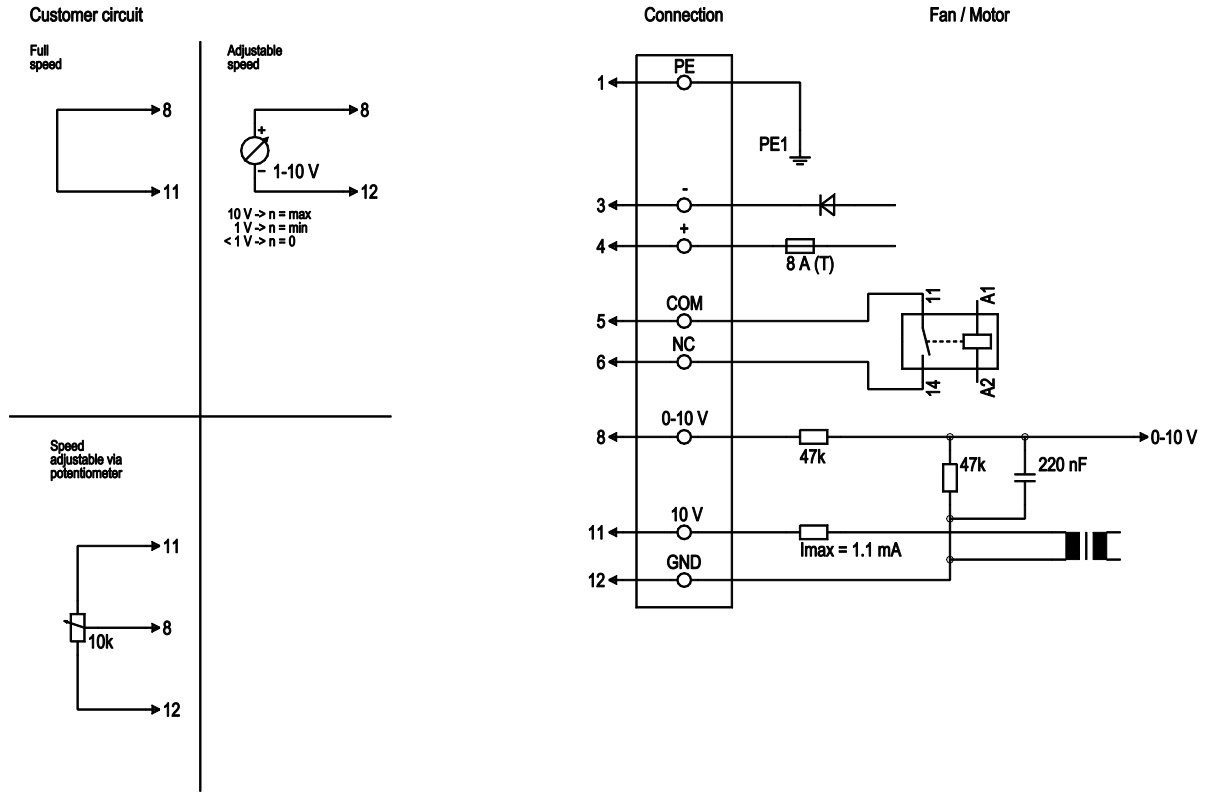

No.	Conn.	Designation	Color	Function/assignment
1	1	PE	green/yellow	Protective earth
1	3	-	blue	Power supply, GND (110 VDC)
1	4	+	red	Power supply, 110 VDC
1	5	NC	white 1	Floating status contact, break for failure
1	6	COM	white 2	Floating status contact, break for failure (0.6 A-110 VDC, 1 A-80 VDC, 3 A-30 VDC)
2	8	0-10 V	yellow	Control input, set value 0-10 VDC, impedance 100 kΩ, SELV
2	11	10 VDC	red	Voltage output 10 VDC (±3%), max. 1.1 mA, power supply for external devices (e.g. potentiometers), SELV
2	12	GND	blue	Reference ground for control interface, SELV



Curves: Air performance

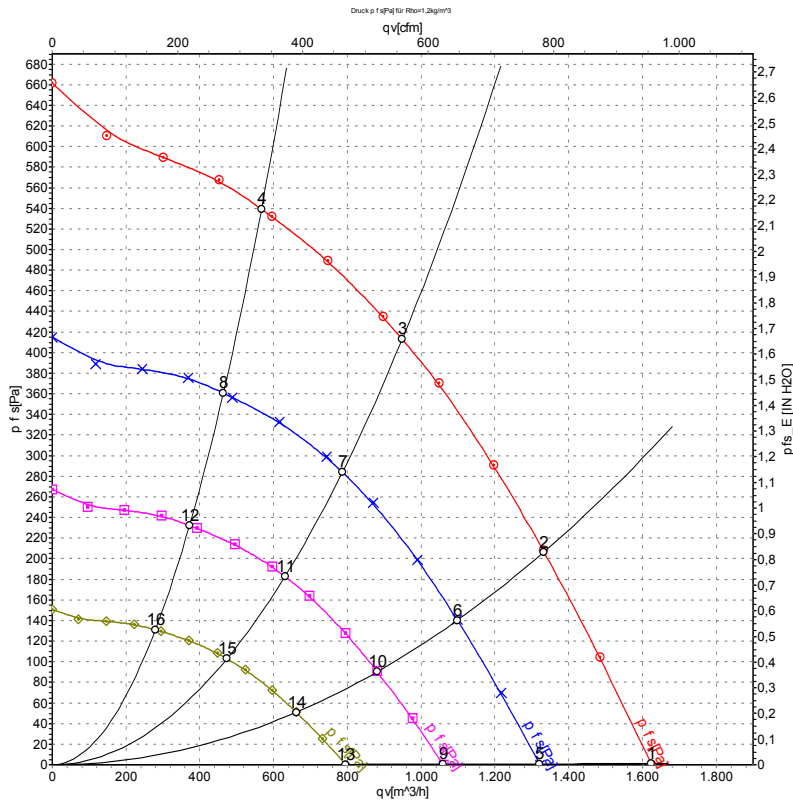

Measurement: LU-105348-1

Air performance measured according to ISO 5801 installation category A. For detailed information on the measurement setup, contact ebmpapst. Intake sound level: Sound power level according to ISO 13347 / sound pressure level measured at 1 m distance from fan axis. The values given are valid under the specified measuring conditions and may vary due to conditions of installation. For deviations from the standard configuration, the parameters have to be checked on the installed unit.

Measured values

	U	n	P _{ed}	I	LpA _{in}	LwA _{in}	q _v	P _{fs}	q _v	P _{fs}
	V	min ⁻¹	W	A	dB(A)	dB(A)	m ³ /h	Pa	cfm	inH2O
1	110	2765	191	1.72	73	80	1625	0	955	0.00
2	110	2730	228	2.07	71	78	1335	210	785	0.84
3	110	2700	250	2.20	70	78	950	415	560	1.67
4	110	2750	216	1.96	72	79	565	540	335	2.17
5	110	2250	103	0.93	69	76	1320	0	780	0.00
6	110	2250	128	1.16	67	74	1100	141	645	0.57
7	110	2250	140	1.27	66	74	785	284	465	1.14
8	110	2250	118	1.07	68	75	465	361	275	1.45
9	110	1805	53	0.48	64	71	1060	0	625	0.00
10	110	1805	66	0.60	62	69	880	91	520	0.37
11	110	1805	72	0.66	61	69	630	183	370	0.73
12	110	1805	61	0.55	63	71	370	232	220	0.93
13	110	1355	22	0.20	58	65	795	0	470	0.00
14	110	1355	28	0.25	56	63	660	51	390	0.20
15	110	1355	31	0.28	55	63	475	103	280	0.41
16	110	1355	26	0.23	57	65	280	131	165	0.53

U = Power supply · n = Speed (rpm) · P_{ed} = Power consumption · I = Current draw · LpA_{in} = Sound pressure level intake side · LwA_{in} = Sound power level intake side · q_v = Air flow
P_{fs} = Pressure increase

