

R3G250-AD64-30

EC centrifugal fan

backward-curved, single-intake



R3G250-AD64-30 ebmpapst Datasheet

sales@fansco.com

www.fansco.com

Limited partnership · Headquarters Mulfingen

Amtsgericht (court of registration) Stuttgart · HRA 590344

General partner Elektrobau Mulfingen GmbH · Headquarters Mulfingen

Amtsgericht (court of registration) Stuttgart · HRB 590142

Nominal data

Type	R3G250-AD64-30	
Motor	M3G084-CA	
Nominal voltage	VDC	24
Nominal voltage range	VDC	16 .. 28
Method of obtaining data		fa
Speed (rpm)	min ⁻¹	2645
Power consumption	W	135
Current draw	A	5.6
Min. ambient temperature	°C	-25
Max. ambient temperature	°C	60

ml = Max. load · me = Max. efficiency · fa = Free air · cs = Customer specification · ce = Customer equipment
Subject to change

Data according to Commission Regulation (EU) 327/2011

		Actual	Req. 2015
01 Overall efficiency η_{es}	%	50.4	43.4
02 Measurement category		A	
03 Efficiency category		Static	
04 Efficiency grade N		69	62
05 Variable speed drive		Yes	

Data obtained at optimum efficiency level.
The ErP data is determined using a motor-impeller combination in a standardized measurement setup.

09 Power consumption P_e	kW	0.17
09 Air flow q_v	m ³ /h	915
09 Pressure increase p_{fs}	Pa	300
10 Speed (rpm) n	min ⁻¹	2455
11 Specific ratio*		1.00

* Specific ratio = $1 + p_{fs} / 100\,000\text{ Pa}$

LU-57101



Technical description

Weight	2.94 kg
Fan size	250 mm
Rotor surface	Painted black
Electronics housing material	Die-cast aluminum
Impeller material	Sheet steel, galvanized
Number of blades	11
Direction of rotation	Clockwise, viewed toward rotor
Degree of protection	IP42
Insulation class	"B"
Moisture (F) / Environmental (H) protection class	H1
Max. permitted ambient temp. for motor (transport/storage)	+80 °C
Min. permitted ambient temp. for motor (transport/storage)	-40 °C
Installation position	Any
Condensation drainage holes	None
Mode	S1
Motor bearing	Ball bearing
Technical features	<ul style="list-style-type: none"> - Tach output - Motor current limitation - Soft start - Control input 0-10 VDC / PWM - Control interface with SELV potential safely disconnected from the mains - Thermal overload protection for motor
EMC immunity to interference	According to EN 61000-6-2 (industrial environment)
EMC interference emission	According to EN 55022 (Class B)
Motor protection	Thermal overload protector (TOP) internally connected
With cable	Variable
Conformity with standards	EN 60950-1; CE
Approval	CSA C22.2 No. 100; UL 1004-1

Product drawing

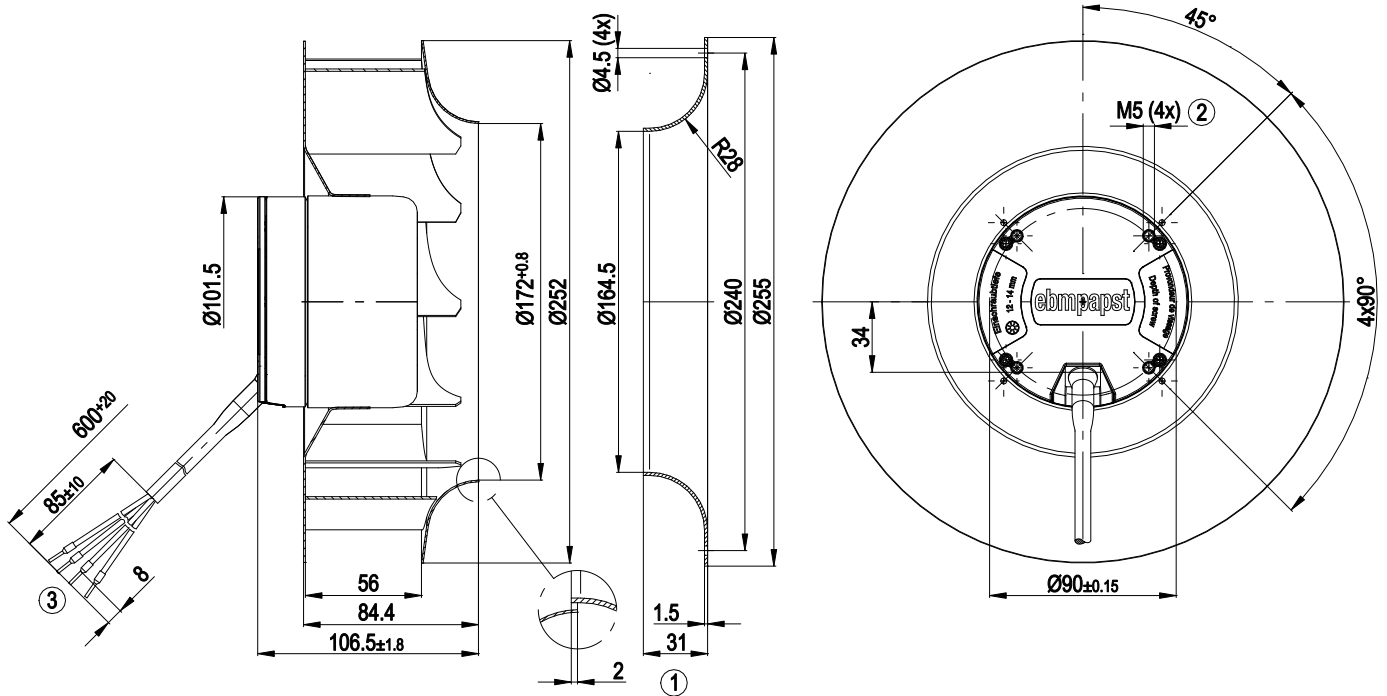

1	Accessory part: inlet ring 96359-2-4013 not included in scope of delivery
2	Clearance for screw 12-14 mm
3	Cable PVC AWG16, 4x crimped ferrules



Connection diagram

Customer circuit

Application instructions for various control options

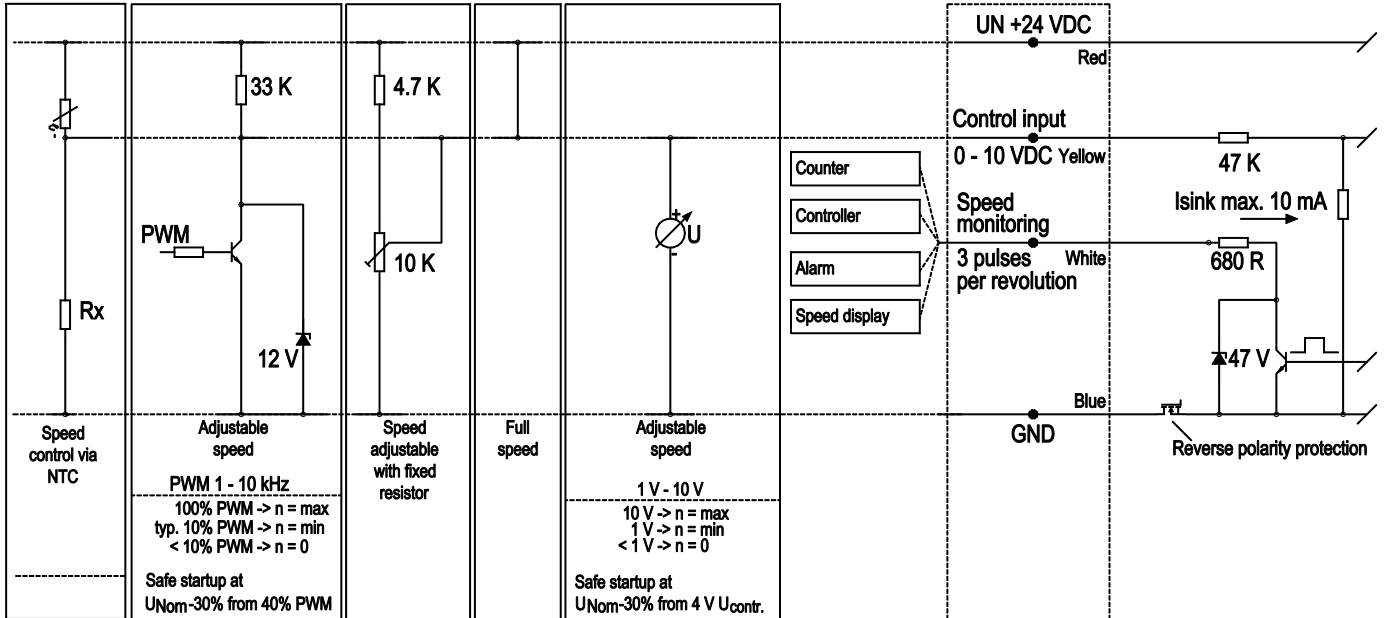

Curves: Air performance

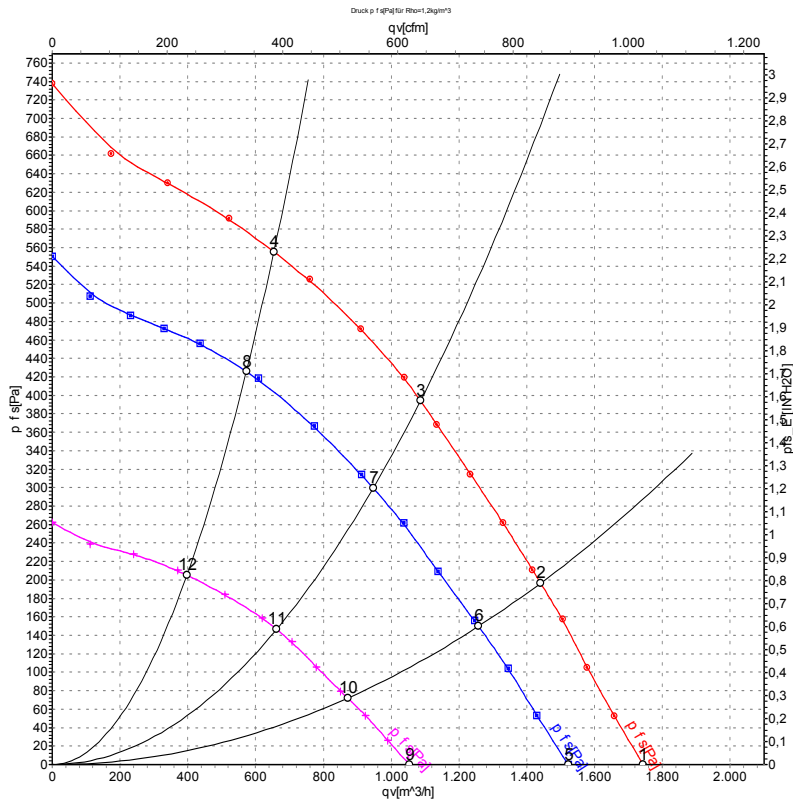

Measurement: LU-57102-1
 Measurement: LU-57101-1
 Measurement: LU-57103-1

Air performance measured according to ISO 5801 installation category A. For detailed information on the measurement setup, contact ebmpapst. Intake sound level: Sound power level according to ISO 13347 / sound pressure level measured at 1 m distance from fan axis. The values given are valid under the specified measuring conditions and may vary due to conditions of installation. For deviations from the standard configuration, the parameters have to be checked on the installed unit.

Measured values

	U	n	P _{ed}	I	q _v	p _{fs}	q _v	p _{fs}
	V	min ⁻¹	W	A	m ³ /h	Pa	cfm	inH ₂ O
1	28	2915	188	6.74	1745	0	1025	0.00
2	28	2845	228	8.16	1440	200	850	0.80
3	28	2810	252	9.02	1085	394	640	1.58
4	28	2845	231	8.28	655	555	385	2.23
5	24	2645	135	5.60	1525	0	895	0.00
6	24	2490	154	6.47	1260	150	740	0.60
7	24	2455	171	7.18	945	300	555	1.20
8	24	2490	158	6.61	575	425	335	1.71
9	16	1765	45	2.88	1055	0	620	0.00
10	16	1735	56	3.55	870	72	515	0.29
11	16	1725	61	3.85	660	146	390	0.59
12	16	1735	57	3.58	395	205	235	0.82

U = Power supply · n = Speed (rpm) · P_{ed} = Power consumption · I = Current draw · q_v = Air flow · p_{fs} = Pressure increase

