

R3G250-AD52-12

EC centrifugal fan

backward curved, single inlet

for railway applications

R3G250-AD52-12 ebmpapst Datasheet

sales@fansco.com

www.fansco.com

Limited partnership · Headquarters Muldingen
County court Stuttgart · HRA 590344

General partner Elektrobau Muldingen GmbH · Headquarters Muldingen
County court Stuttgart · HRB 590142

Nominal data

Type	R3G250-AD52-12	
Motor	M3G084-CA	
Nominal voltage	VDC	24
Nominal voltage range	VDC	16 .. 28
Type of data definition		ml
Speed (rpm)	min ⁻¹	2950
Power input	W	270
Min. ambient temperature	°C	-25
Max. ambient temperature	°C	60

ml = Max. load · me = Max. efficiency · fa = Running at free air · cs = Customer specs · cu = Customer unit
Subject to alterations



EC centrifugal fan

backward curved, single inlet
for railway applications

Technical features

Mass	3.08 kg
Size	250 mm
Surface of rotor	Coated in black
Material of impeller	Sheet steel, galvanised
Number of blades	11
Direction of rotation	Clockwise, seen on rotor
Type of protection	IP 42
Insulation class	"B"
Max. permissible ambient motor temp. (transp./ storage)	+80 °C
Min. permissible ambient motor temp. (transp./storage)	-40 °C
Mounting position	Shaft horizontal or rotor on top; rotor on bottom on request
Condensate discharge holes	None
Operation mode	S1
Motor bearing	Ball bearing
EMC directives	EN 50121-3-2; EN 50155
Cable exit	Lateral



EC centrifugal fan

backward curved, single inlet
for railway applications

Product drawing

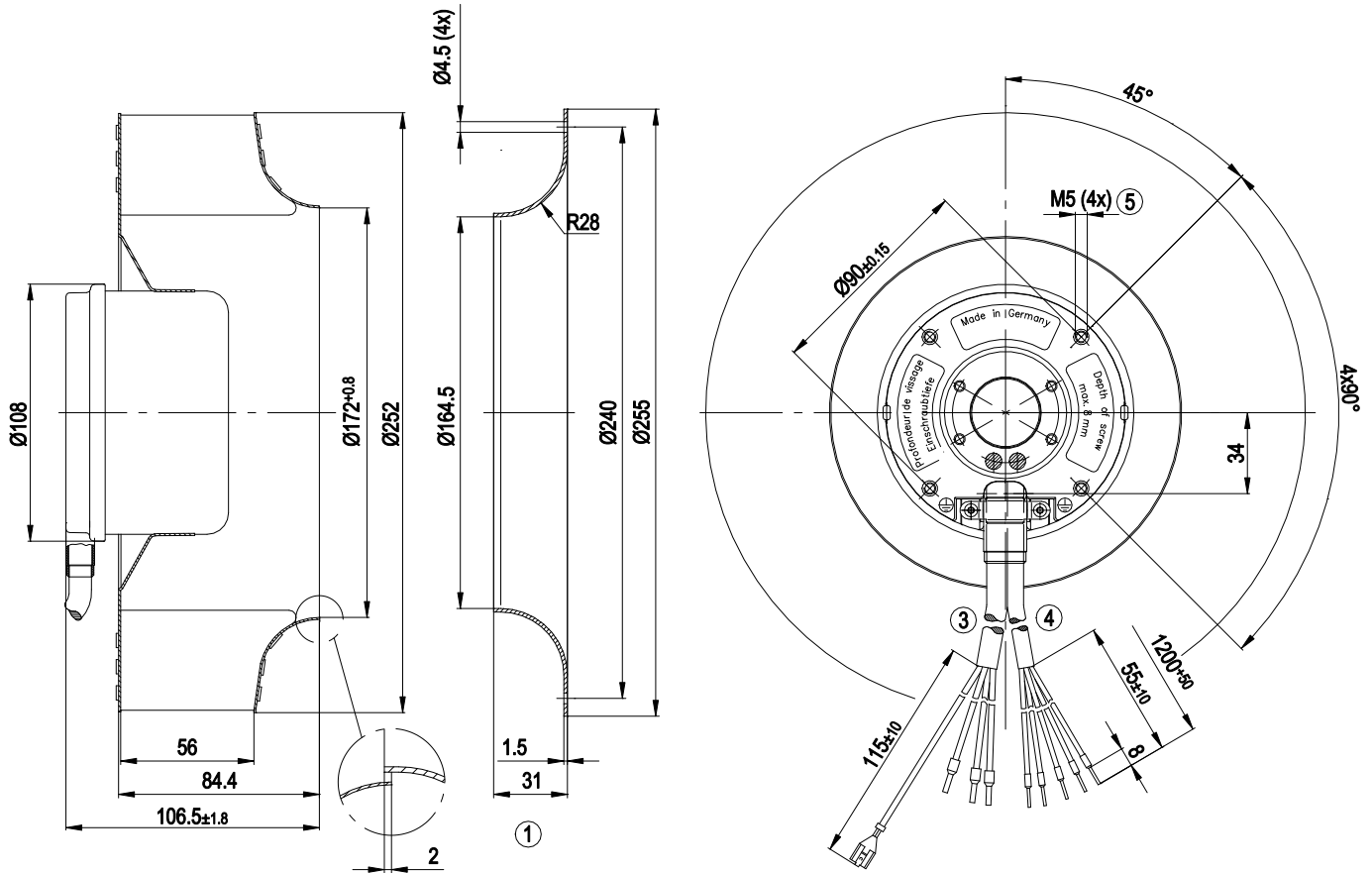

1	Accessory part: Inlet nozzle 96359-2-4013, not included in the standard scope of delivery
2	Accessory part: External electronics CHG032-AA01-01 not included in the standard scope of delivery
3	Connection line silicone $4 \times 1.5 \text{ mm}^2$, 3 x core-end sleeves and crimped receptacle for tabs 6.3×0.8
4	Connection line silicone $5 \times 0.5 \text{ mm}^2$, 5 x crimped core end sleeves
5	Depth of screw max. 8 mm



EC centrifugal fan

backward curved, single inlet
for railway applications

Connection screen

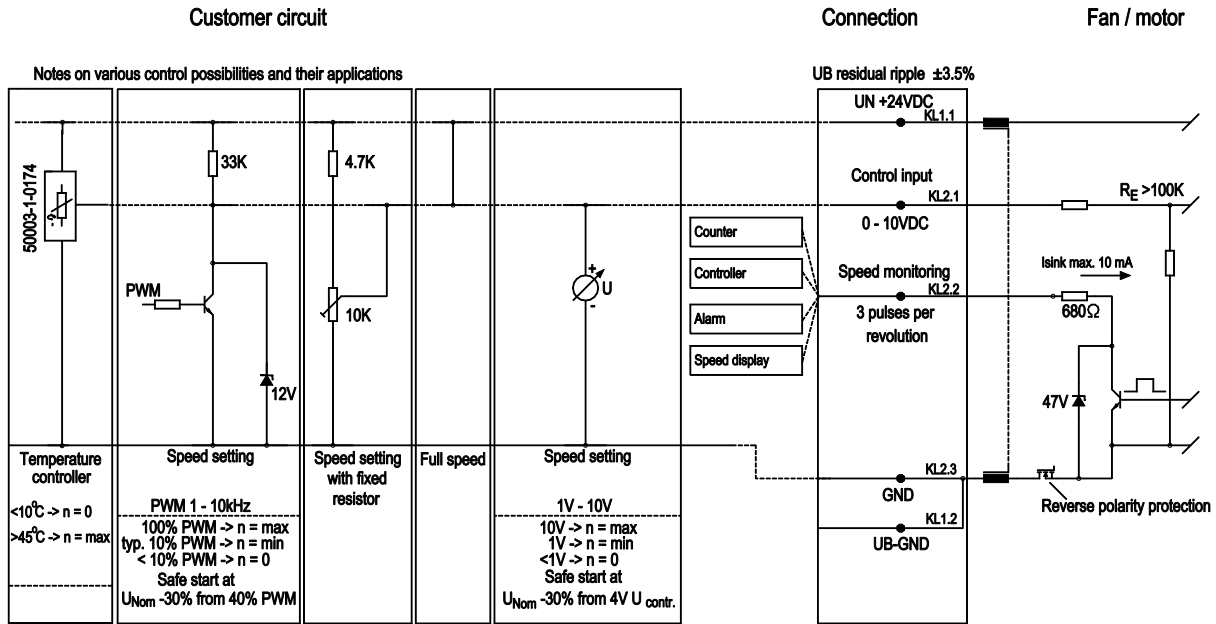

Pin configuration for external electronics: CHG032AA0101

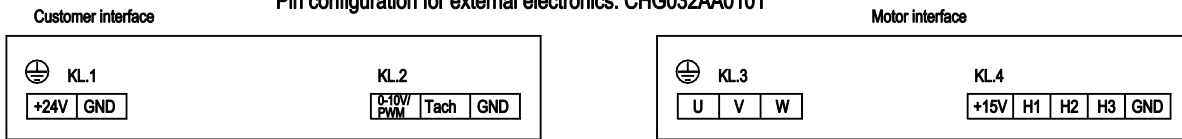

No.	Conn.	Designation	Function / assignment
KL.3		+15V	red
KL.3		GND	blue
KL.3		H1	orange
KL.3		H2	brown
KL.3		H3	yellow
KL.4		U	black
KL.4		V	blue
KL.4		W	brown
PE		PE	green/yellow



Charts: Air flow

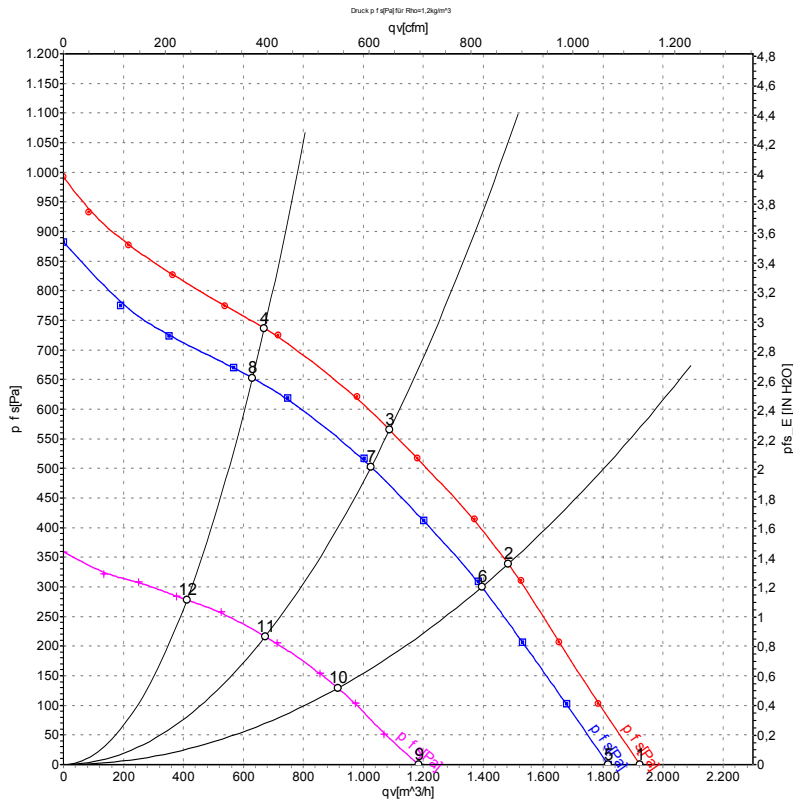

Measurement: LU-40709-1
 Measurement: LU-40708-1
 Measurement: LU-40710-1

Air performance measured as per ISO 5801 Installation category A. For detailed information on the measuring set-up, please contact ebm-papst. Suction-side noise levels: L_{WA} measured as per ISO 13347 / L_{pA} measured with 1m distance to fan axis. The values given are valid under the measuring conditions mentioned above and may vary according to the actual installation situation. With any deviation from the standard set-up, the specific values have to be checked and reviewed with the unit installed.

Measured values

	U	n	P _{ed}	I	q _v	p _{fs}	q _v	p _{fs}
	V	min ⁻¹	W	A	m ³ /h	Pa	cfm	inH ₂ O
1	28	3415	258	9.18	1925	0	1130	0.00
2	28	3265	334	11.91	1485	339	875	1.36
3	28	3225	353	12.62	1090	565	640	2.27
4	28	3280	328	11.70	670	738	395	2.96
5	26	3195	214	8.23	1815	0	1070	0.00
6	26	3070	279	10.70	1395	300	820	1.20
7	26	3035	295	11.36	1025	500	605	2.01
8	26	3085	273	10.48	630	650	370	2.61
9	16	2085	63	3.95	1185	0	695	0.00
10	16	2030	82	5.13	915	129	540	0.52
11	16	2010	87	5.44	675	217	395	0.87
12	16	2030	80	4.98	410	278	240	1.12

U = Supply voltage · n = Speed (rpm) · P_{ed} = Power input · I = Current draw · q_v = Air flow · p_{fs} = Pressure increase

