

R3G250-AB70-11

EC centrifugal fan

backward-curved, single-intake



R3G250-AB70-11 ebmpapst Datasheet
sales@fansco.com
www.fansco.com

Limited partnership · Headquarters Muldingen
Amtsgericht (court of registration) Stuttgart · HRA 590344

General partner Elektrobau Muldingen GmbH · Headquarters Muldingen
Amtsgericht (court of registration) Stuttgart · HRB 590142



Nominal data

Type	R3G250-AB70-11	
Motor	M3G074-CF	
Phase		1~
Nominal voltage	VAC	115
Nominal voltage range	VAC	100 .. 130
Frequency	Hz	50/60
Method of obtaining data		ml
Speed (rpm)	min ⁻¹	2300
Power consumption	W	170
Current draw	A	2.2
Min. ambient temperature	°C	-25
Max. ambient temperature	°C	50

ml = Max. load · me = Max. efficiency · fa = Free air · cs = Customer specification · ce = Customer equipment
Subject to change

Data according to ErP Directive

		Actual	Req. 2015			
01 Overall efficiency η_{es}	%	47.2	43.1	09 Power consumption P_{ed}	kW	0.16
02 Measurement category		A		09 Air flow q_v	m ³ /h	755
03 Efficiency category		Static		09 Pressure increase p_{fs}	Pa	324
04 Efficiency grade N		66.1	62	10 Speed (rpm) n	min ⁻¹	2365
05 Variable speed drive		Yes		11 Specific ratio*		1.00

Data obtained at optimum efficiency level.
The ErP data is determined using a motor-impeller combination in a standardized measurement setup.

* Specific ratio = $1 + p_{fs} / 100\,000\text{ Pa}$

LU-132953



Technical description

Weight	2.6 kg
Fan size	250 mm
Impeller material	Sheet steel, hot-dip galvanized
Direction of rotation	Clockwise, viewed toward rotor
Degree of protection	IP44; installation- and position-dependent
Insulation class	"B"
Moisture (F) / Environmental (H) protection class	F3-1
Max. permitted ambient temp. for motor (transport/storage)	+ 80 °C
Min. permitted ambient temp. for motor (transport/storage)	- 40 °C
Installation position	Shaft horizontal or rotor on top; rotor on bottom on request
Condensation drainage holes	None
Mode	S1
Motor bearing	Ball bearing
Technical features	<ul style="list-style-type: none"> - Output 10 VDC, max. 1.1 mA - Tach output - Motor current limitation - Soft start - Control input 0-10 VDC / PWM - Thermal overload protection for electronics/motor
EMC immunity to interference	According to EN 61000-6-1
EMC circuit feedback	According to EN 61000-3-2/3
EMC interference emission	According to EN 61000-6-3 (household environment)
Touch current according to IEC 60990 (measuring circuit Fig. 4, TN system)	<= 3.5 mA
Motor protection	Thermal overload protector (TOP) internally connected
With cable	Variable
Protection class	I (with customer connection of protective earth)
Conformity with standards	EN 60335-1
Approval	CSA C22.2 No. 77; UL 2111

Product drawing

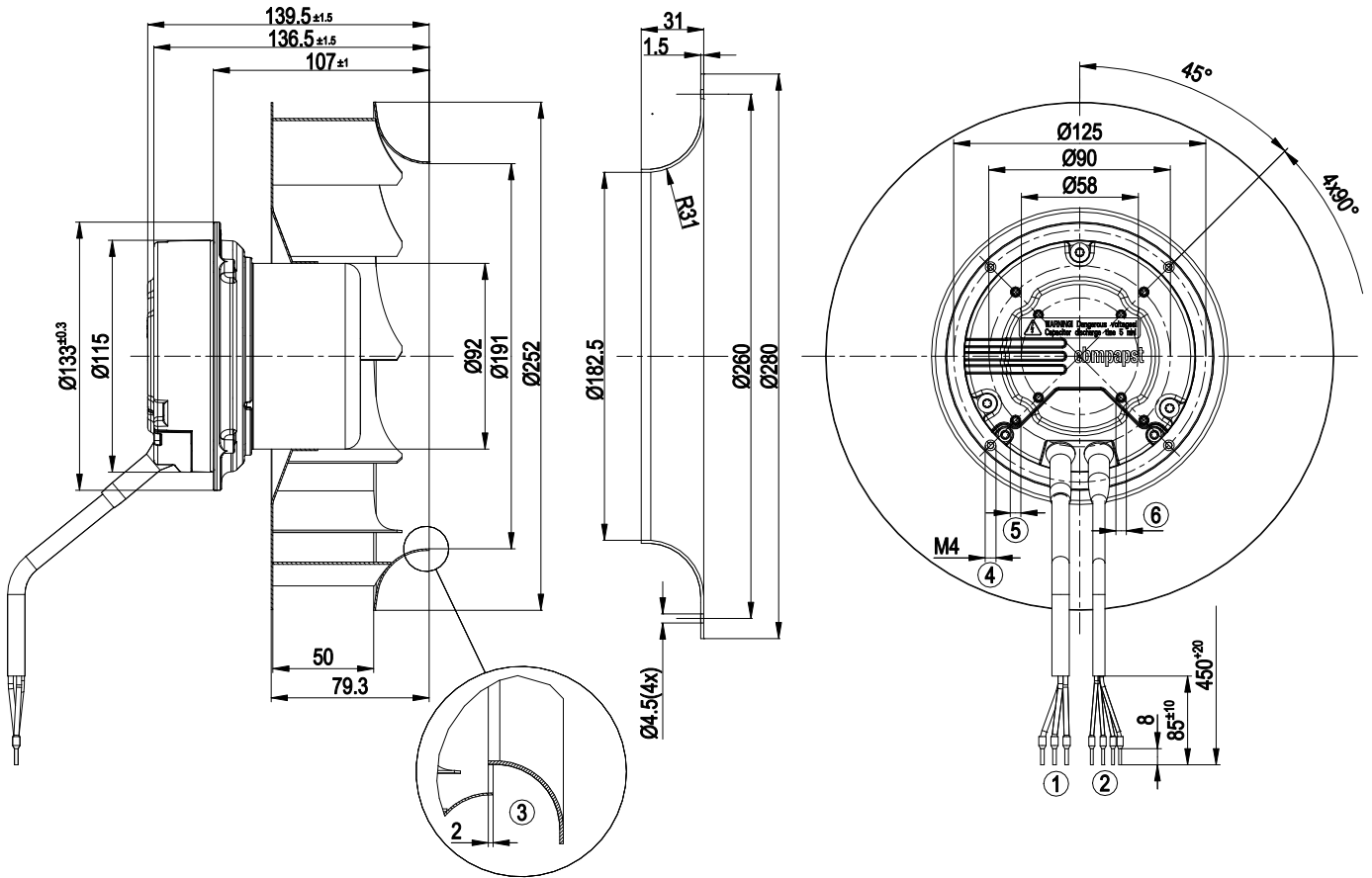

1	Cable AWG18, 3 x crimped ferrules
2	Cable AWG22, 4 x crimped ferrules
3	Accessory part: Inlet ring 96360-2-4013 not included in scope of delivery, other inlet rings on request
4	Clearance for screw 8-10 mm, tightening torque 2.5±0.2 Nm; gluing the screws is recommended
5	Tapping hole ready for self-tapping M4 screw, max. clearance for screw 6 mm
6	Tapping hole ready for self-tapping M4 screw, max. clearance for screw 8 mm

Connection diagram

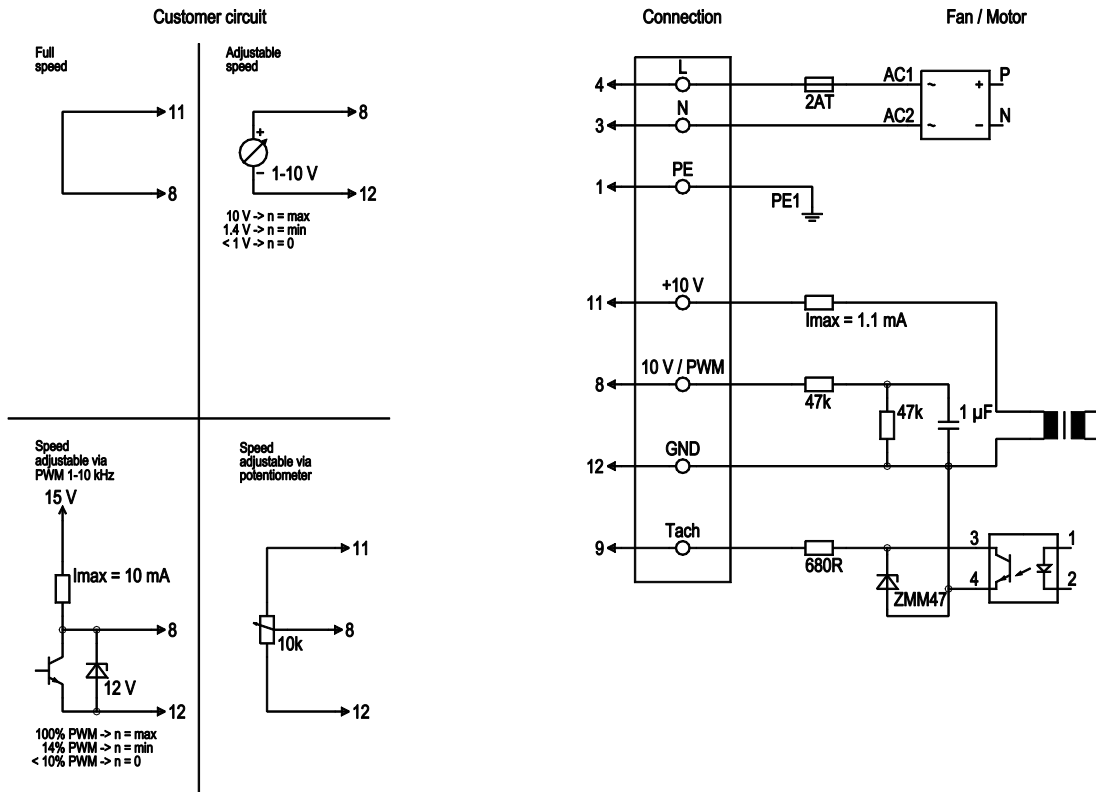

No.	Conn.	Designation	Color	Function/assignment
	4	L	black	Power supply 230 VAC, 50-60 Hz, see nameplate for voltage range
	3	N	blue	Neutral conductor
	1	PE	green/yellow	Protective earth
	8	0-10 V PWM	yellow	Control input 0-10 V or PWM, electrically isolated
	9	Tach	white	Tach output: open collector, 1 pulse per revolution, electrically isolated
	11	10V / max 1.1 mA	red	Voltage output 10 V/max. 1.1 mA, electrically isolated
	12	GND	blue	GND connection for control interface



Curves: Air performance 60 Hz

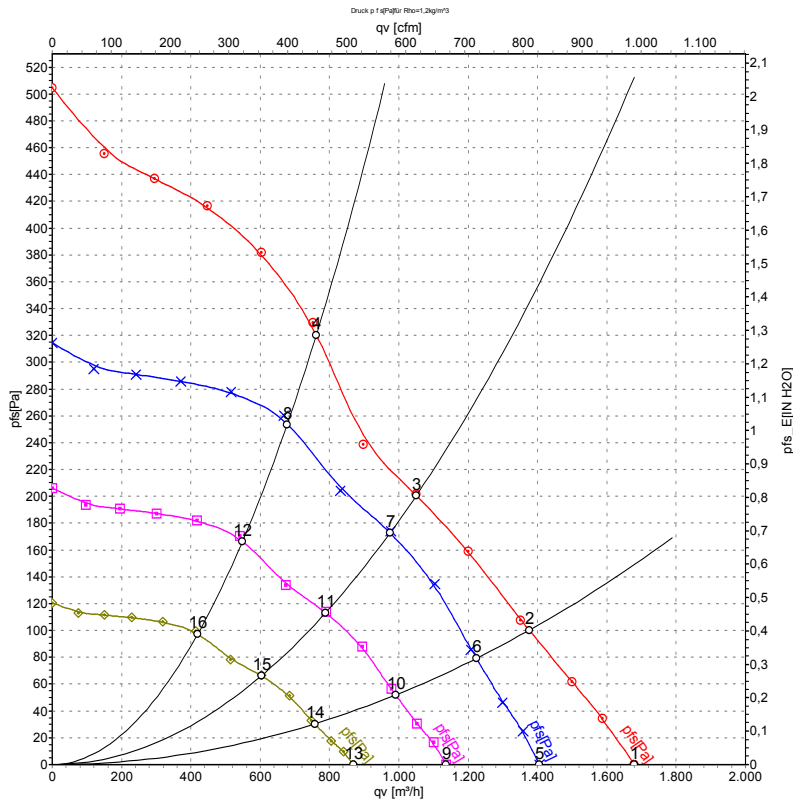

Measurement: LU-132953-1

Air performance measured according to ISO 5801 installation category A. For detailed information on the measurement setup, contact ebmpapst. Intake sound level: Sound power level according to ISO 13347 / sound pressure level measured at 1 m distance from fan axis. The values given are valid under the specified measuring conditions and may vary due to conditions of installation. For deviations from the standard configuration, the parameters have to be checked on the installed unit.

Measured values

	U	f	n	P _{ed}	I	q _v	p _{fs}	q _v	p _{fs}
	V	Hz	min ⁻¹	W	A	m ³ /h	Pa	CFM	inH2O
1	115	60	2510	168	2.07	1680	0	990	0.00
2	115	60	2365	170	2.15	1375	100	810	0.40
3	115	60	2260	170	2.15	1050	200	620	0.80
4	115	60	2355	164	2.07	760	320	450	1.28
5	115	60	2100	98	1.21	1405	0	825	0.00
6	115	60	2100	119	1.51	1225	79	720	0.32
7	115	60	2100	132	1.68	975	174	575	0.70
8	115	60	2100	116	1.47	680	257	400	1.03
9	115	60	1700	52	0.64	1135	0	670	0.00
10	115	60	1700	63	0.80	990	52	585	0.21
11	115	60	1700	70	0.89	790	114	465	0.46
12	115	60	1700	61	0.78	550	168	325	0.67
13	115	60	1300	23	0.29	870	0	510	0.00
14	115	60	1300	28	0.36	760	30	445	0.12
15	115	60	1300	31	0.40	605	67	355	0.27
16	115	60	1300	27	0.35	420	98	245	0.39

U = Power supply · f = Frequency · n = Speed (rpm) · P_{ed} = Power consumption · I = Current draw · q_v = Air flow · p_{fs} = Pressure increase

