

R3G225-RG54-13 ebmpapst Datasheet

sales@fansco.com

www.fansco.com

Limited partnership · Headquarters Mulfingen

Amtsgericht (court of registration) Stuttgart · HRA 590344

General partner Elektrobau Mulfingen GmbH · Headquarters Mulfingen

Amtsgericht (court of registration) Stuttgart · HRB 590142



Nominal data

Type	R3G225-RG54-13	
Motor	M3G074-CF	
Phase		1~
Nominal voltage	VAC	230
Nominal voltage range	VAC	200 .. 277
Frequency	Hz	50/60
Method of obtaining data		ml
Speed (rpm)	min ⁻¹	2930
Power consumption	W	170
Current draw	A	1.34
Min. ambient temperature	°C	-25
Max. ambient temperature	°C	60

ml = Max. load · me = Max. efficiency · fa = Free air · cs = Customer specification · ce = Customer equipment
Subject to change

Data according to ErP Directive

		Actual	Req. 2015			
01 Overall efficiency η_{es}	%	59.6	43.1	09 Power consumption P_{ed}	kW	0.16
02 Measurement category		A		09 Air flow q_v	m ³ /h	805
03 Efficiency category		Static		09 Pressure increase p_{fs}	Pa	390
04 Efficiency grade N		78.5	62	10 Speed (rpm) n	min ⁻¹	2885
05 Variable speed drive		Yes		11 Specific ratio*		1.00

Data obtained at optimum efficiency level.

The ErP data is determined using a motor-impeller combination in a standardized measurement setup.

* Specific ratio = $1 + p_{fs} / 100\,000\text{ Pa}$

LU-127769



Technical description

Weight	2.2 kg
Fan size	225 mm
Rotor surface	Thick-film passivated
Impeller material	PA plastic
Number of blades	7
Direction of rotation	Clockwise, viewed toward rotor
Degree of protection	IP44; installation- and position-dependent as per EN 60034-5
Insulation class	"B"
Moisture (F) / Environmental (H) protection class	F3-1
Max. permitted ambient temp. for motor (transport/storage)	+ 80 °C
Min. permitted ambient temp. for motor (transport/storage)	- 40 °C
Installation position	Shaft horizontal or rotor on top; rotor on bottom on request
Condensation drainage holes	None
Mode	S1
Motor bearing	Ball bearing
Technical features	<ul style="list-style-type: none"> - Output 10 VDC, max. 1.1 mA - Tach output - Soft start - Control input 0-10 VDC / PWM - Thermal overload protection for motor
EMC immunity to interference	According to EN 61000-6-2 (industrial environment)
EMC circuit feedback	According to EN 61000-3-2/3
EMC interference emission	According to EN 61000-6-3 (household environment)
Touch current according to IEC 60990 (measuring circuit Fig. 4, TN system)	<= 3.5 mA
Motor protection	Thermal overload protector (TOP) internally connected
With cable	Variable
Protection class	I (with customer connection of protective earth)
Conformity with standards	EN 60335-1
Approval	CSA C22.2 No. 77; UL 2111

Product drawing

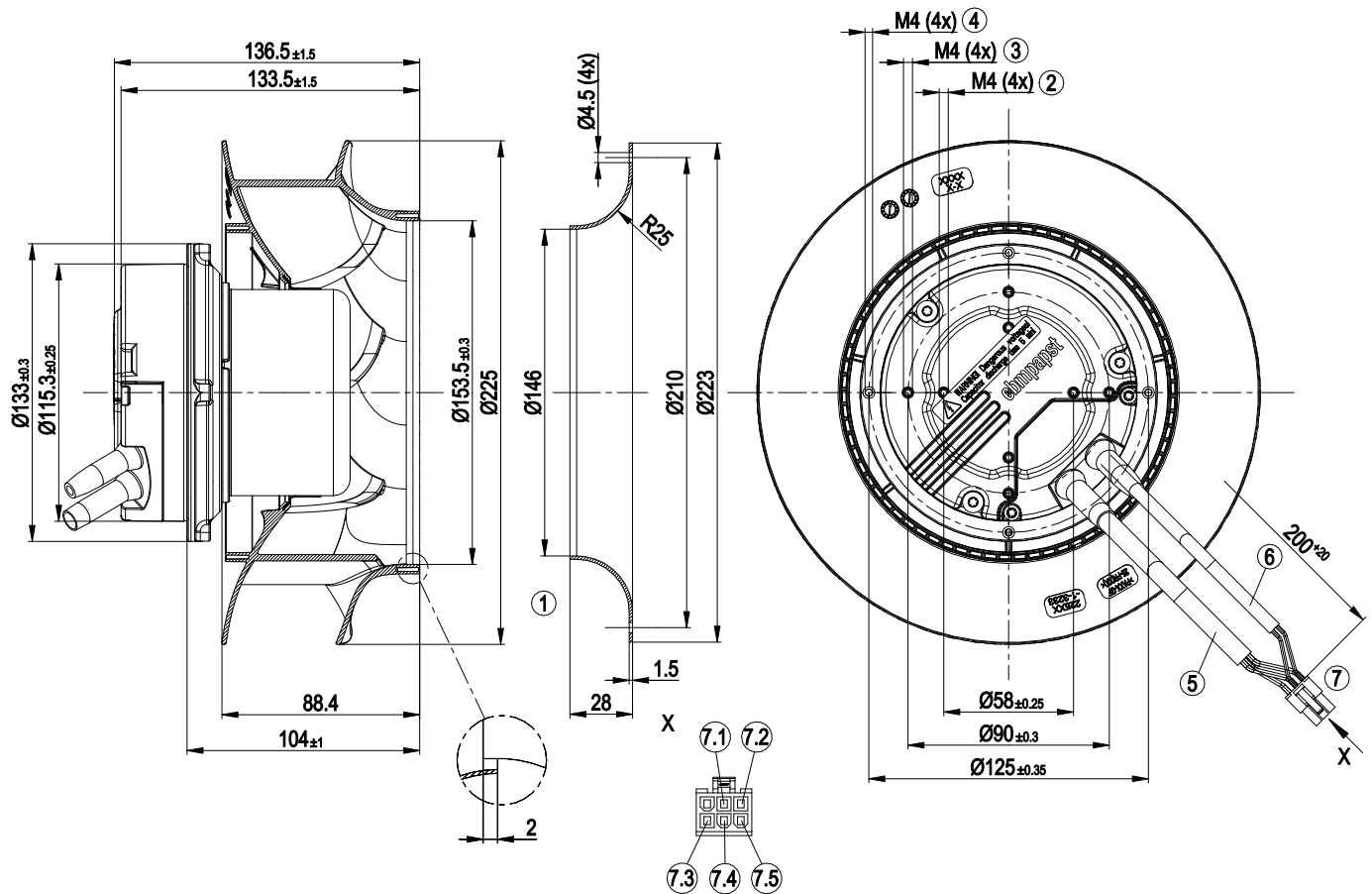

1	Accessory part: inlet ring 96358-2-4013 not included in scope of delivery
2	Tapping hole ready for self-tapping M4 screw, max. clearance for screw 8 mm
3	Tapping hole ready for self-tapping M4 screw, max. clearance for screw 6 mm
4	Clearance for screw 8 - 10 mm
5	Cable PVC AWG18, 3x socket Tyco 1586315-1 crimped
6	Cable PVC AWG22, 2x socket Tyco 1586315-1 crimped
7	Connector housing: Tyco-VAL-U-Lok 1586765-6
7.1	GND (blue)
7.2	0-10 V/PWM (yellow)
7.3	L (black)
7.4	N (blue)
7.5	PE (yellow/green)

Connection diagram

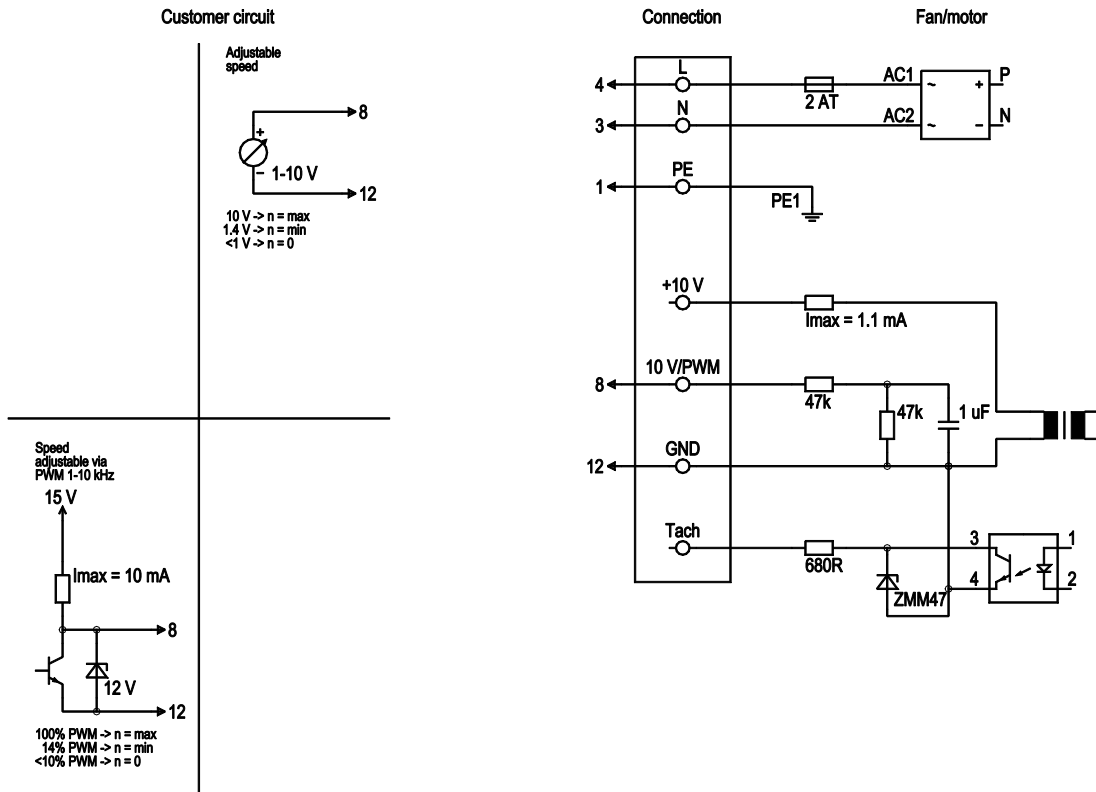

No.	Conn.	Designation	Color	Function/assignment
	4	L	black	Power supply 230 VAC, 50-60 Hz, see nameplate for voltage range
	3	N	blue	Neutral conductor
	1	PE	green/yellow	Protective earth
	8	0-10 V PWM	yellow	Control input 0-10 V or PWM, electrically isolated
	12	GND	blue	GND connection for control interface

Curves: Air performance 50 Hz

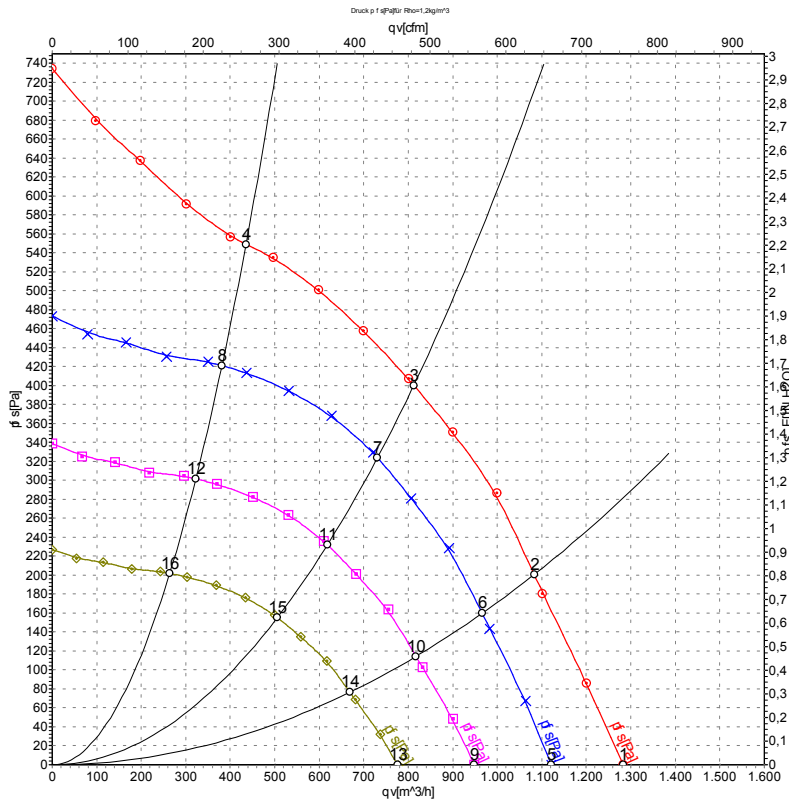

Measurement: LU-127769-1

Air performance measured according to ISO 5801 installation category A. For detailed information on the measurement setup, contact ebmpapst. Intake sound level: Sound power level according to ISO 13347 / sound pressure level measured at 1 m distance from fan axis. The values given are valid under the specified measuring conditions and may vary due to conditions of installation. For deviations from the standard configuration, the parameters have to be checked on the installed unit.

Measured values

	U	f	n	P _{ed}	I	LpA _{in}	LwA _{in}	qv	p _{fs}	qv	p _{fs}
	V	Hz	min ⁻¹	W	A	dB(A)	dB(A)	m ³ /h	Pa	CFM	inH2O
1	230	50	2980	151	1.22	69	77	1285	0	755	0.00
2	230	50	2915	168	1.25	66	73	1085	200	635	0.80
3	230	50	2930	170	1.34	60	68	810	400	480	1.61
4	230	50	2970	150	1.23	64	72	435	550	255	2.21
5	230	50	2600	100	0.81	66	74	1120	0	660	0.00
6	230	50	2600	119	0.95	63	71	965	160	570	0.64
7	230	50	2600	121	0.98	58	66	730	325	430	1.30
8	230	50	2600	101	0.83	61	69	380	421	225	1.69
9	230	50	2200	61	0.49	63	71	950	0	560	0.00
10	230	50	2200	72	0.57	60	67	815	114	480	0.46
11	230	50	2200	73	0.59	54	62	620	233	365	0.94
12	230	50	2200	61	0.50	57	65	325	302	190	1.21
13	230	50	1800	33	0.27	58	66	775	0	455	0.00
14	230	50	1800	40	0.31	55	63	670	77	395	0.31
15	230	50	1800	40	0.33	50	58	505	156	300	0.63
16	230	50	1800	34	0.27	53	61	265	202	155	0.81

U = Power supply · f = Frequency · n = Speed (rpm) · P_{ed} = Power consumption · I = Current draw · LpA_{in} = Sound pressure level intake side · LwA_{in} = Sound power level intake side
 qv = Air flow · p_{fs} = Pressure increase

