

R3G225-RE27-30 ebmpapst Datasheet

sales@fansco.com

www.fansco.com

Nominal data

Type	R3G225-RE27-30	
Motor	M3G055-DF	
Phase		1~
Nominal voltage	VAC	230
Nominal voltage range	VAC	200 .. 240
Frequency	Hz	50/60
Method of obtaining data		ml
Speed (rpm)	min ⁻¹	3100
Power consumption	W	220
Current draw	A	1.8
Min. ambient temperature	°C	-25
Max. ambient temperature	°C	40

ml = Max. load · me = Max. efficiency · fa = Free air · cs = Customer specification · ce = Customer equipment
Subject to change

Data according to Commission Regulation (EU) 327/2011 (EN 17166)

		Actual	Req. 2015			
01 Overall efficiency η_{es}	%	58	44.5	09 Power consumption P_{ed}	kW	0.21
02 Measurement category		A		09 Air flow q_v	m ³ /h	1050
03 Efficiency category		Static		09 Pressure increase p_{fs}	Pa	384
04 Efficiency grade N		75.5	62	10 Speed (rpm) n	min ⁻¹	3125
05 Variable speed drive		Yes		11 Specific ratio*		1.00

Data obtained at optimum efficiency level.

The ErP data is determined using a motor-impeller combination in a standardized measurement setup.

* Specific ratio = $1 + p_{fs} / 100\,000\text{ Pa}$

LU-203849



Technical description

Weight	1.8 kg
Size	225 mm
Motor size	55
Rotor surface	Thick-film passivated
Impeller material	PA plastic
Number of blades	7
Direction of rotation	Clockwise, viewed toward rotor
Degree of protection	IP54
Insulation class	"B"
Moisture (F) / Environmental (H) protection class	H1
Max. permitted ambient temp. for motor (transport/storage)	+ 80 °C
Min. permitted ambient temp. for motor (transport/storage)	- 40 °C
Installation position	Shaft horizontal or rotor on bottom; rotor on top on request
Condensation drainage holes	None, open rotor
Mode	S1
Motor bearing	Ball bearing
Technical features	<ul style="list-style-type: none"> - Output 10 VDC, max. 10 mA - Tach output - Power limiter - Soft start - Control input 0-10 VDC / PWM - Thermal overload protection for motor - Line undervoltage detection
EMC immunity to interference	According to EN 61000-6-2 (industrial environment)
EMC interference emission	According to EN 61000-6-4 (industrial environment)
Touch current according to IEC 60990 (measuring circuit Fig. 4, TN system)	<= 3.5 mA
Electrical hookup	Connector with cable
Motor protection	Electronic motor protection
With cable	Variable
Protection class	I (with customer connection of protective earth)
Conformity with standards	EN 60335-1; CE

Product drawing

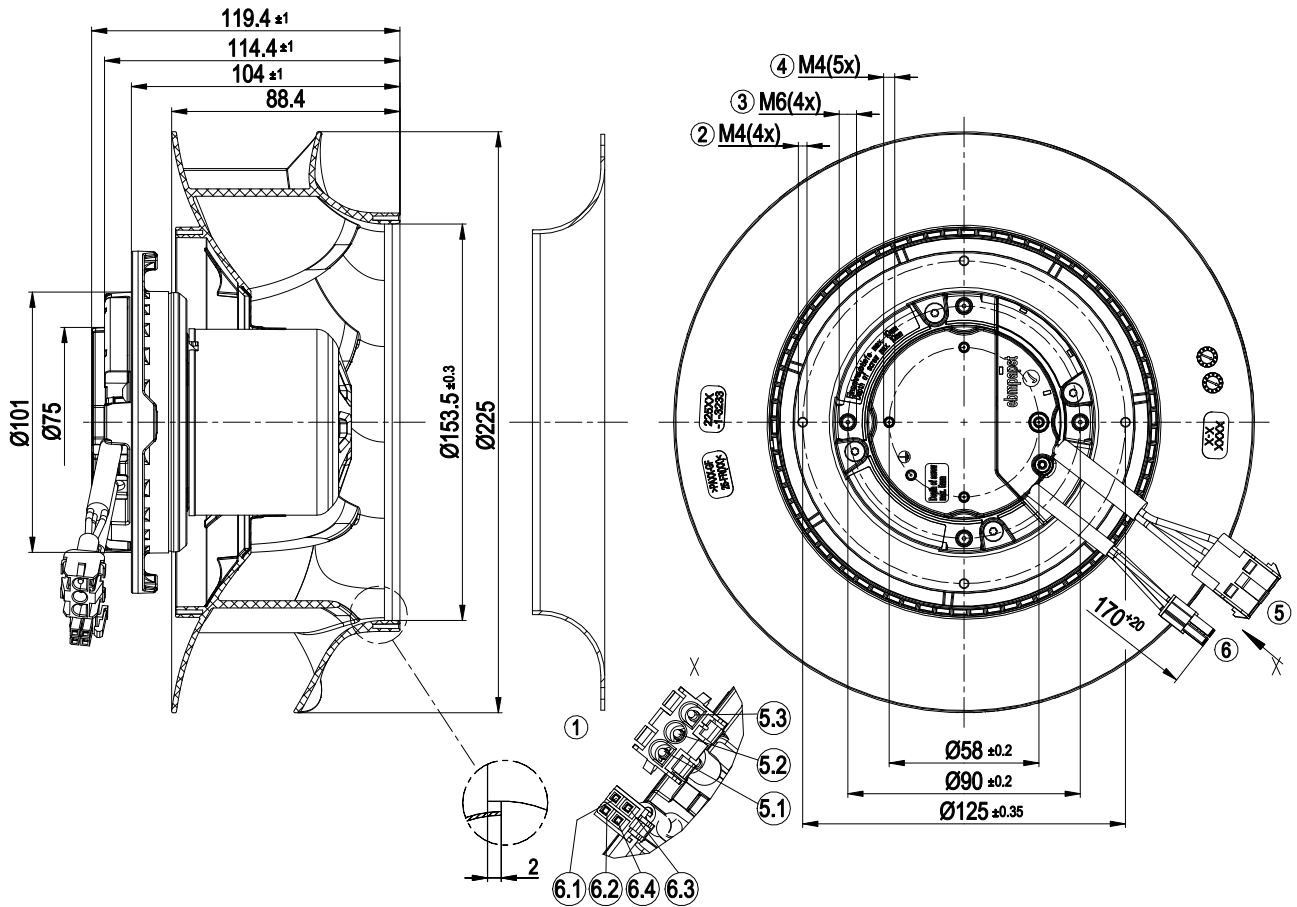

1	Accessory part: inlet ring 96358-2-4013 not included in scope of delivery
2	Clearance for screw 8-10 mm
3	Max. clearance for screw 10 mm
4	Max. clearance for screw 5 mm
5	Cable PVC AWG18 3-pole connector housing TE 2178474-2 Plug pin TE 350654-1 2x plug pin TE 350218-1
5.1	L (black)
5.2	N (blue)
5.3	PE (green/yellow)
6	Cable PVC AWG22 4-pole connector housing TE 1586765-4 4x socket TE 794956-3
6.1	GND (blue)
6.2	0-10 V/PWM (yellow)
6.3	+10 V (red)
6.4	Tach (white)

EC centrifugal fan

forward-curved, single-intake

Accessory part

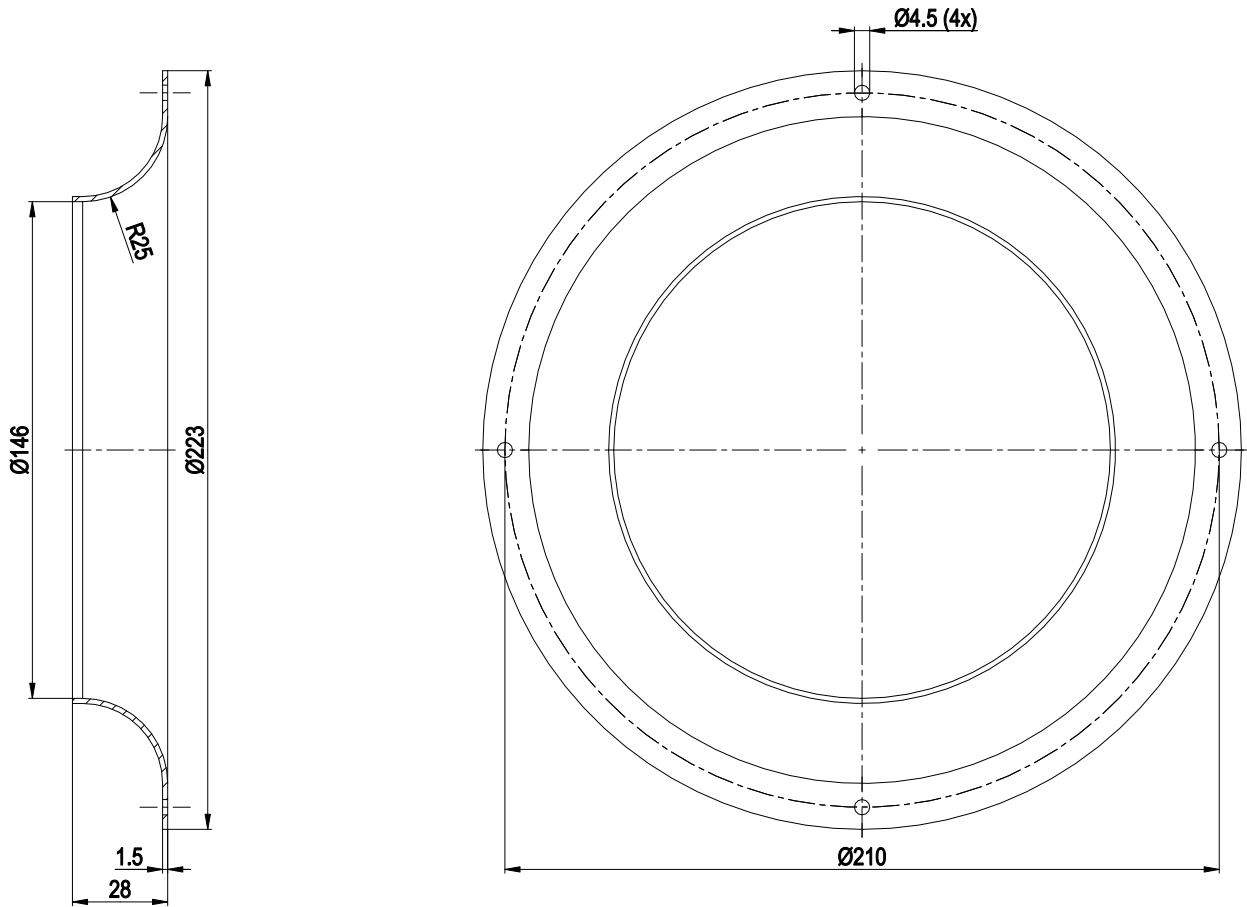

Inlet ring 96358-2-4013 not included in scope of delivery



Connection diagram

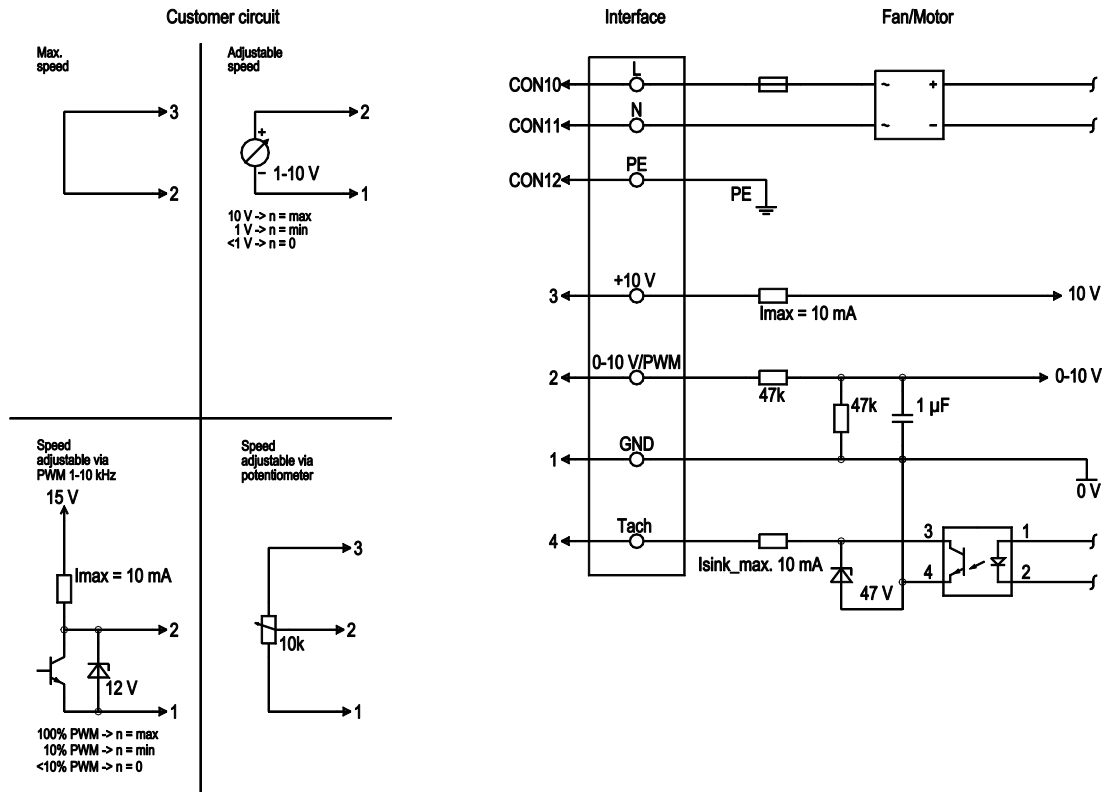

No.	Conn.	Designation	Color	Function/assignment
	CON10	L	black	Supply connection, power supply, phase, see nameplate for voltage range
	CON11	N	blue	Supply connection, power supply, neutral conductor, see nameplate for voltage range
	CON12	PE	green/yellow	Ground connection
	2	0- 10V PWM	yellow	0-10 V / PWM control input, Ri=100 kΩ, SELV
	4	Tach	white	Tach output, open collector, 1 pulse per revolution, Isink max = 10 mA, SELV
	3	+10 V	red	Fixed voltage output 10 VDC +/-3 %, Imax. 10 mA, short-circuit-proof, power supply for ext. devices (e.g. pot), SELV
	1	GND	blue	Reference ground for control interface, SELV

Curves: Air performance 50 Hz

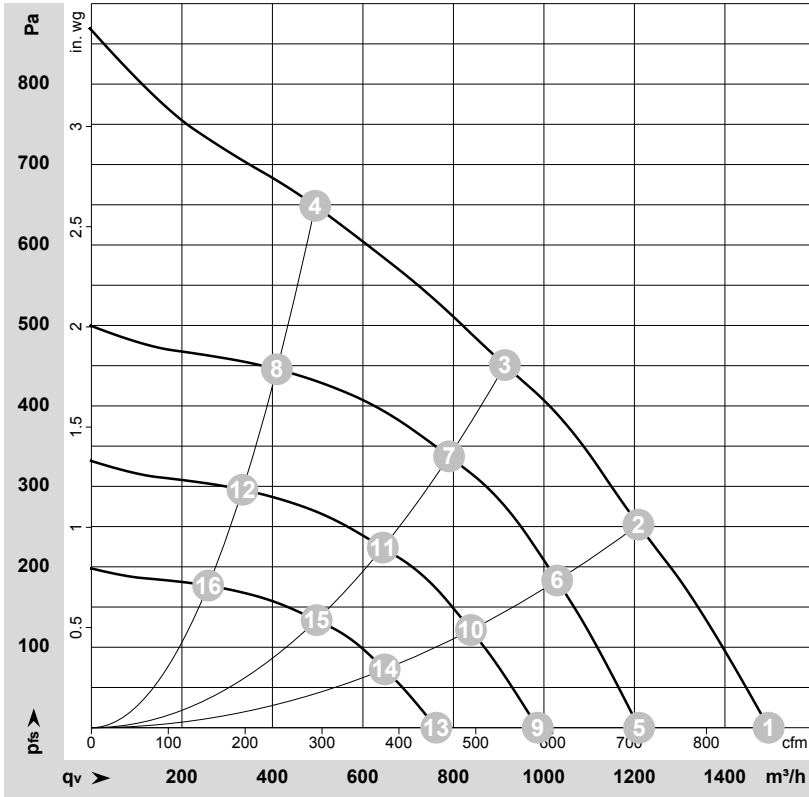

$\rho = 1.15 \text{ kg/m}^3 \pm 2 \%$

Measurement: LU-203849-1

Air performance measured according to ISO 5801 installation category A. For detailed information on the measurement setup, contact ebmpapst. Intake sound level: Sound power level according to ISO 13347 / sound pressure level measured at 1 m distance from fan axis. The values given are valid under the specified measuring conditions and may vary due to conditions of installation. For deviations from the standard configuration, the parameters have to be checked on the installed unit.

Measured values

	Wired	U	f	n	P _{ed}	I	q _v	P _{fs}	q _v	P _{fs}
		V	Hz	min ⁻¹	W	A	m ³ /h	Pa	cfm	in. wg
1	1~	230	50	3340	198	1.65	1495	0	880	0.00
2	1~	230	50	3165	220	1.80	1210	250	710	1.00
3	1~	230	50	3100	220	1.80	915	450	540	1.81
4	1~	230	50	3260	212	1.75	495	650	290	2.61
5	1~	230	50	2700	105	0.87	1210	0	710	0.00
6	1~	230	50	2700	139	1.14	1030	184	605	0.74
7	1~	230	50	2700	144	1.18	790	338	465	1.36
8	1~	230	50	2700	121	1.00	410	446	240	1.79
9	1~	230	50	2200	57	0.47	985	0	580	0.00
10	1~	230	50	2200	75	0.61	840	122	495	0.49
11	1~	230	50	2200	78	0.64	645	224	380	0.90
12	1~	230	50	2200	65	0.54	335	296	195	1.19
13	1~	230	50	1700	26	0.22	760	0	450	0.00
14	1~	230	50	1700	35	0.28	650	73	380	0.29
15	1~	230	50	1700	36	0.30	500	134	295	0.54
16	1~	230	50	1700	30	0.25	260	177	150	0.71

Wired = Wiring · U = Voltage · f = Frequency · n = Speed (rpm) · P_{ed} = Power consumption · I = Current draw · q_v = Air flow · p_{fs} = Pressure increase

