

R3G225-RE07-28 ebmpapst Datasheet

sales@fansco.com

www.fansco.com

Nominal data

Type	R3G225-RE07-28	
Motor	M3G055-DF	
Phase		1~
Nominal voltage	VAC	230
Nominal voltage range	VAC	200 .. 240
Frequency	Hz	50/60
Method of obtaining data		ml
Speed (rpm)	min ⁻¹	2860
Power consumption	W	170
Current draw	A	1.4
Min. ambient temperature	°C	-25
Max. ambient temperature	°C	60

ml = Max. load · me = Max. efficiency · fa = Free air · cs = Customer specification · ce = Customer equipment
Subject to change

Data according to Commission Regulation (EU) 327/2011 (EN 17166)

		Actual	Req. 2015			
01 Overall efficiency η_{es}	%	61.7	43.3	09 Power consumption P_{ed}	kW	0.16
02 Measurement category		A		09 Air flow q_v	m ³ /h	705
03 Efficiency category		Static		09 Pressure increase p_{fs}	Pa	458
04 Efficiency grade N		80.4	62	10 Speed (rpm) n	min ⁻¹	2865
05 Variable speed drive		Yes		11 Specific ratio*		1.00

Data obtained at optimum efficiency level.

The ErP data is determined using a motor-impeller combination in a standardized measurement setup.

* Specific ratio = $1 + p_{fs} / 100\,000\text{ Pa}$

LU-127001



Technical description

Weight	1.82 kg
Size	225 mm
Motor size	55
Rotor surface	Thick-film passivated
Impeller material	PA plastic
Number of blades	7
Direction of rotation	Clockwise, viewed toward rotor
Degree of protection	IP54
Insulation class	"B"
Moisture (F) / Environmental (H) protection class	H1
Max. permitted ambient temp. for motor (transport/storage)	+ 80 °C
Min. permitted ambient temp. for motor (transport/storage)	- 40 °C
Installation position	Any
Condensation drainage holes	None, open rotor
Mode	S1
Motor bearing	Ball bearing
Technical features	<ul style="list-style-type: none"> - Output 10 VDC, max. 10 mA - Tach output - Power limiter - Motor current limitation - Soft start - Control input 0-10 VDC / PWM - Control interface with SELV potential safely disconnected from the mains - Overvoltage detection - Thermal overload protection for electronics/motor - Line undervoltage detection
EMC immunity to interference	According to EN 61000-6-2 (industrial environment)
EMC interference emission	According to EN 61000-6-4 (industrial environment)
Touch current according to IEC 60990 (measuring circuit Fig. 4, TN system)	<= 3.5 mA
Motor protection	Electronic motor protection
With cable	Variable
Protection class	I (with customer connection of protective earth)
Conformity with standards	EN 60034-1; EN 60204-1; EN 60335-1; CE
Approval	UL 1004-7 + 60730-1

Product drawing

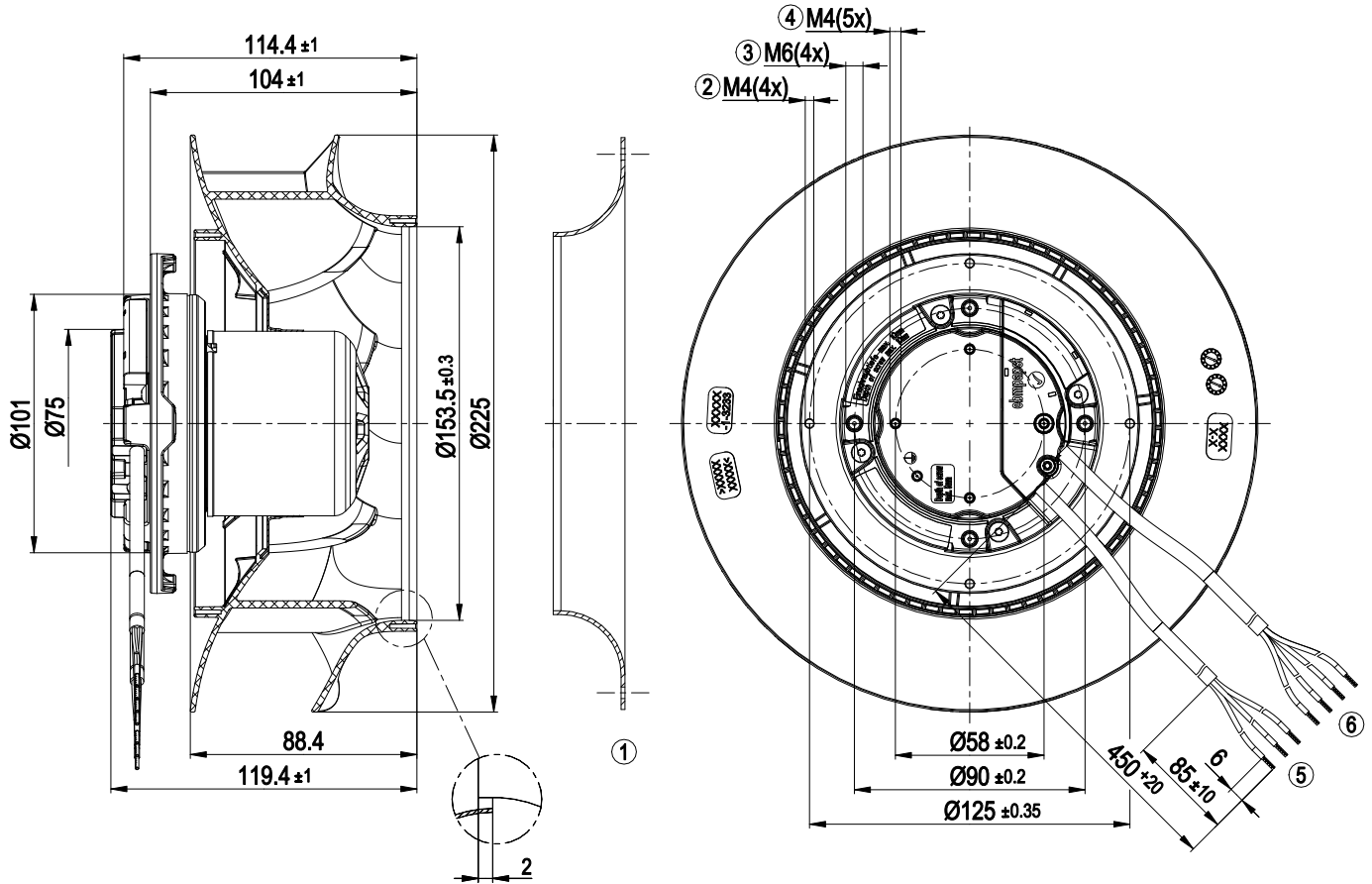

1	Accessory part: inlet ring 96358-2-4013 not included in scope of delivery
2	Clearance for screw 8-10 mm
3	Max. clearance for screw 10 mm
4	Max. clearance for screw 5 mm
5	Cable PVC AWG20
-	3x splice
6	Cable PVC AWG22
	4x splice

Accessory part

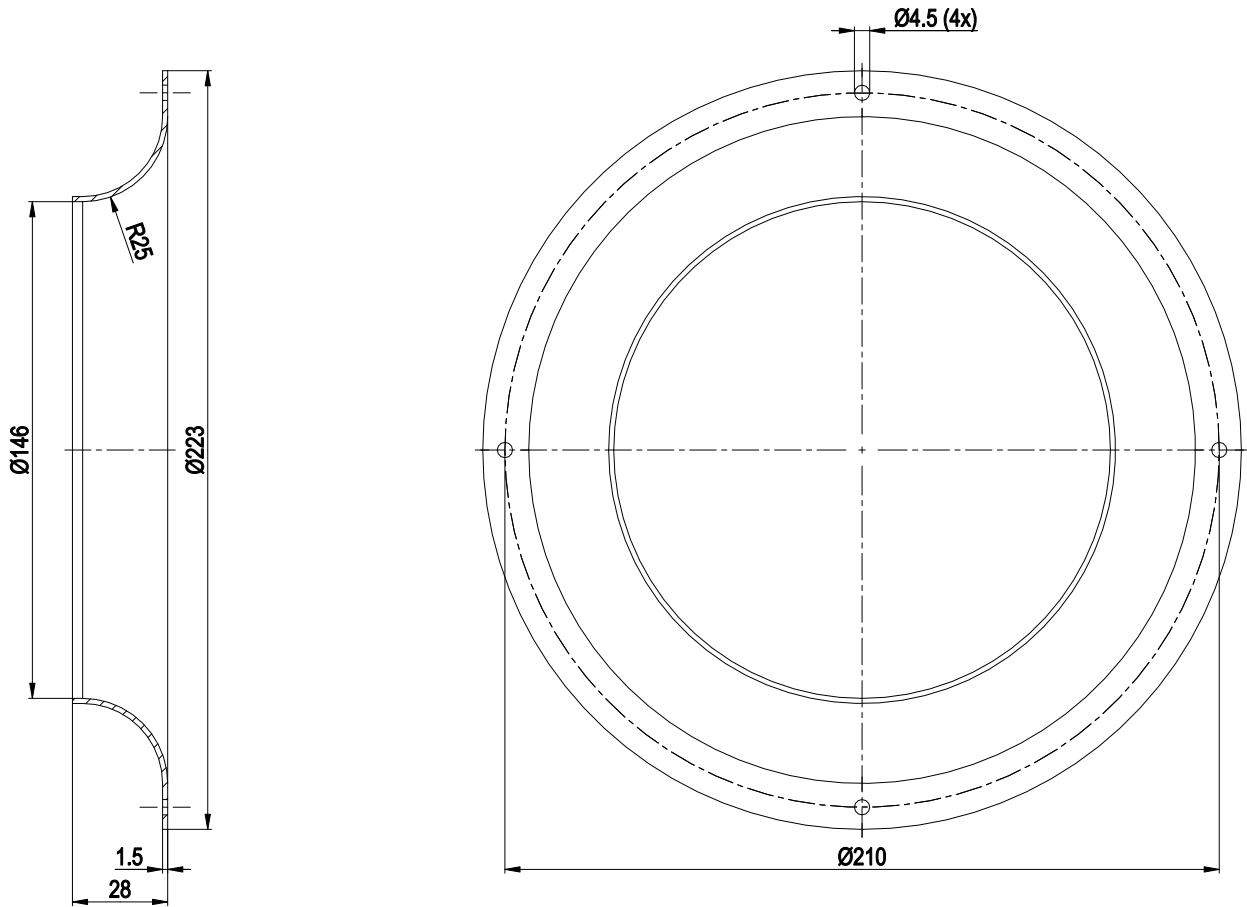

Inlet ring 96358-2-4013

Connection diagram

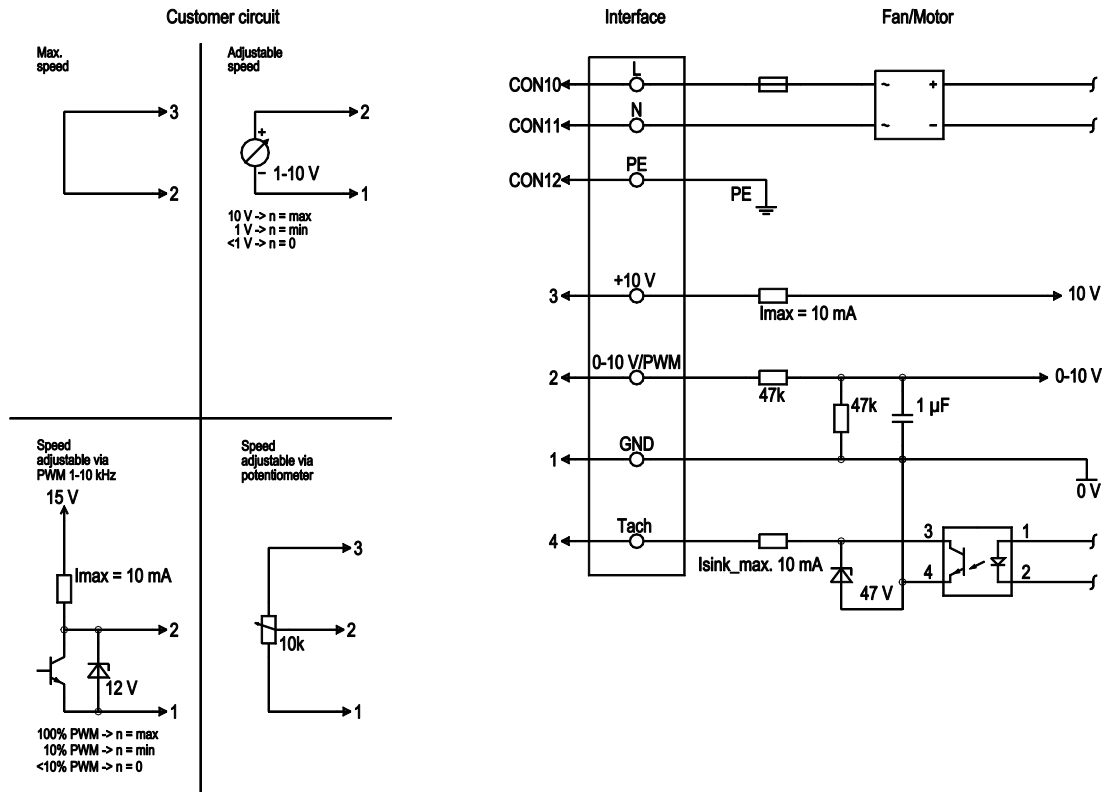

No.	Conn.	Designation	Color	Function/assignment
	CON10	L	black	Supply connection, power supply, phase, see nameplate for voltage range
	CON11	N	blue	Supply connection, power supply, neutral conductor, see nameplate for voltage range
	CON12	PE	green/yellow	Ground connection
	2	0- 10V PWM	yellow	0-10 V / PWM control input, R _i =100 kΩ, SELV
	4	Tach	white	Tach output, open collector, 1 pulse per revolution, I _{sink max} = 10 mA, SELV
	3	+10 V	red	Fixed voltage output 10 VDC +/-3 %, I _{max} . 10 mA, short-circuit-proof, power supply for ext. devices (e.g. pot), SELV
	1	GND	blue	Reference ground for control interface, SELV

Curves: Air performance 50 Hz

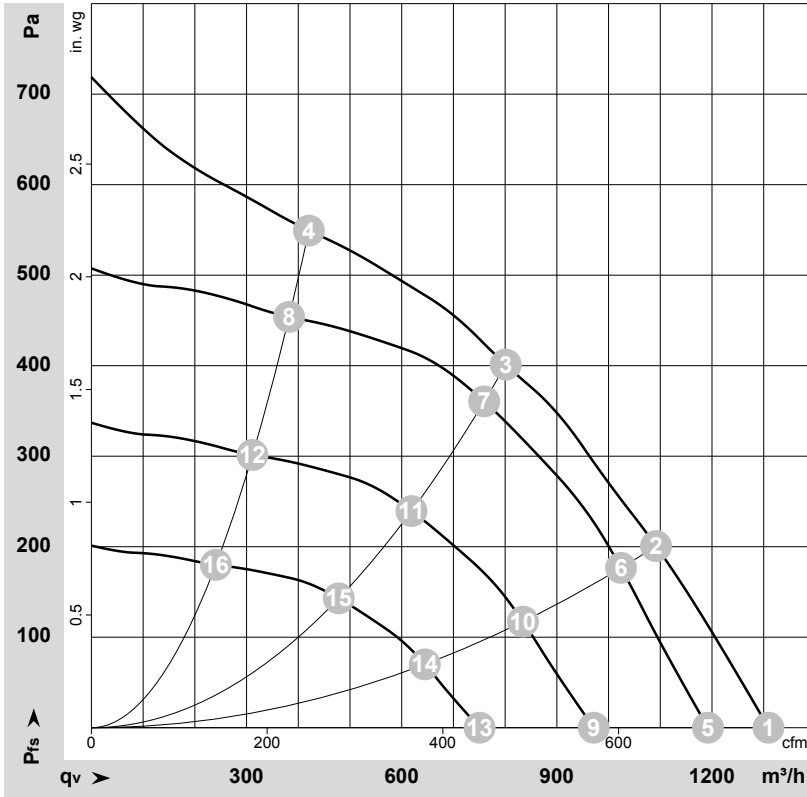

$\rho = 1.15 \text{ kg/m}^3 \pm 2 \%$

Measurement: LU-127001-1

Air performance measured according to ISO 5801 installation category A. For detailed information on the measurement setup, contact ebmpapst. Intake sound level: Sound power level according to ISO 13347 / sound pressure level measured at 1 m distance from fan axis. The values given are valid under the specified measuring conditions and may vary due to conditions of installation. For deviations from the standard configuration, the parameters have to be checked on the installed unit.

Measured values

	U	f	n	P _{ed}	I	LpA _{in}	LwA _{in}	q _v	P _{fs}	q _v	P _{fs}
	V	Hz	min ⁻¹	W	A	dB(A)	dB(A)	m ³ /h	Pa	cfm	in. wg
1	230	50	2965	147	1.17	70	78	1310	0	770	0.00
2	230	50	2880	170	1.40	66	74	1090	200	645	0.80
3	230	50	2860	170	1.40	60	68	800	400	470	1.61
4	230	50	2970	149	1.22	66	74	420	550	250	2.21
5	230	50	2700	111	0.89	68	76	1190	0	700	0.00
6	230	50	2700	138	1.10	64	72	1025	178	605	0.71
7	230	50	2700	145	1.15	58	67	760	362	445	1.45
8	230	50	2700	112	0.92	64	72	380	454	225	1.82
9	230	50	2200	60	0.48	63	70	970	0	570	0.00
10	230	50	2200	75	0.59	59	67	835	118	490	0.47
11	230	50	2200	79	0.62	53	61	620	240	365	0.96
12	230	50	2200	61	0.50	59	67	310	301	185	1.21
13	230	50	1700	28	0.22	56	64	750	0	440	0.00
14	230	50	1700	34	0.27	53	60	645	71	380	0.29
15	230	50	1700	36	0.29	47	55	480	143	280	0.57
16	230	50	1700	28	0.23	52	60	240	180	140	0.72

U = Voltage · f = Frequency · n = Speed (rpm) · P_{ed} = Power consumption · I = Current draw · LpA_{in} = Sound pressure level intake side · LwA_{in} = Sound power level intake side
 q_v = Air flow · p_{fs} = Pressure increase

