

R3G225-RE07-18 ebmpapst Datasheet

sales@fansco.com

www.fansco.com

Limited partnership · Headquarters Mulfingen
County court Stuttgart · HRA 590344

General partner Elektrobau Mulfingen GmbH · Headquarters Mulfingen
County court Stuttgart · HRB 590142

Nominal data

Type	R3G225-RE07-18	
Motor	M3G055-DF	
Phase		1~
Nominal voltage	VAC	230
Nominal voltage range	VAC	200 .. 240
Frequency	Hz	50/60
Type of data definition		ml
Speed (rpm)	min ⁻¹	2860
Power input	W	170
Current draw	A	1.4
Min. ambient temperature	°C	-25
Max. ambient temperature	°C	60

ml = Max. load · me = Max. efficiency · fa = Running at free air · cs = Customer specs · cu = Customer unit
Subject to alterations

Data in accordance with ecodesign regulation EU 327/2011

		Actual	Request 2015			
01 Overall efficiency η_{es}	%	61.7	43.1	09 Power input P_{ed}	kW	0.16
02 Measurement category		A		09 Air flow q_v	m ³ /h	705
03 Efficiency category		Static		09 Pressure increase p_{fs}	Pa	458
04 Efficiency grade N		80.6	62	10 Speed (rpm) n	min ⁻¹	2865
05 Variable speed drive		Yes		11 Specific ratio [*]		1.00

Data definition with optimum efficiency.

The ErP data is determined using a motor-impeller combination in a standardised measurement configuration.

^{*} Specific ratio = $1 + p_{fs} / 100\,000\text{ Pa}$

LU-127001



Technical features

Mass	1.7 kg
Size	225 mm
Surface of rotor	Thick layer passivated
Material of impeller	PA plastic
Number of blades	7
Direction of rotation	Clockwise, seen on rotor
Type of protection	IP 54
Insulation class	"B"
Max. permissible ambient motor temp. (transp./ storage)	+ 80 °C
Min. permissible ambient motor temp. (transp./storage)	- 40 °C
Mounting position	Any
Condensate discharge holes	None, open rotor
Operation mode	S1
Motor bearing	Ball bearing
Technical features	<ul style="list-style-type: none"> - Output 10 VDC, max. 10 mA - Tach output - Output limit - Motor current limit - Soft start - Control input 0-10 VDC / PWM - Control interface with SELV potential safely disconnected from the mains - Overvoltage detection - Over-temperature protected electronics / motor - Line undervoltage detection
Touch current acc. IEC 60990 (measuring network Fig. 4, TN system)	<= 3.5 mA
Motor protection	Locked-rotor protection
Cable exit	Variable
Protection class	I (if protective earth is connected by customer)
Product conforming to standard	EN 60335-1; CE
Approval	CCC; UL 1004-7 + 60730; C22.2 Nr.77 + CAN/CSA-E60730-1; EAC

Product drawing

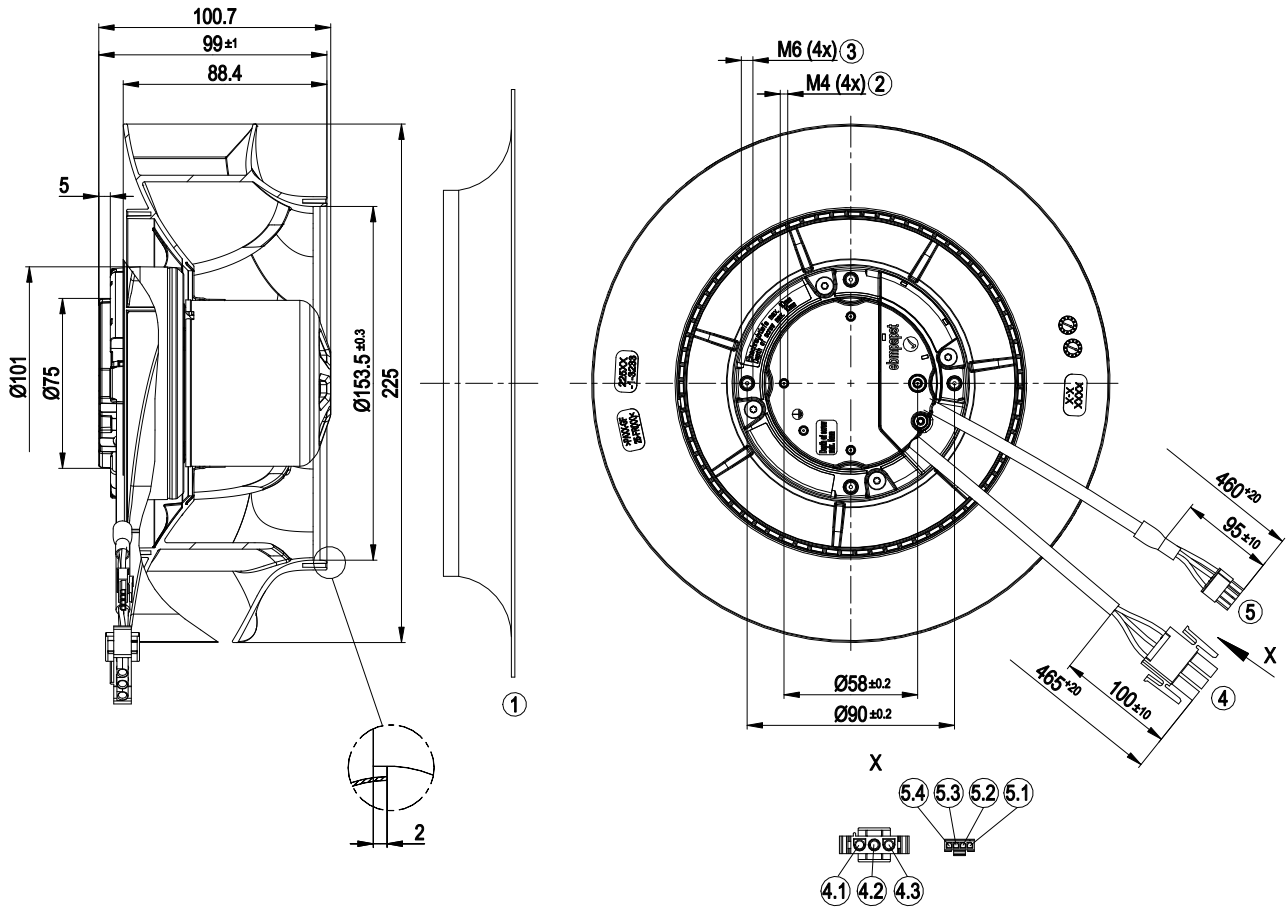

1	Accessory part: Inlet nozzle 96358-2-4013 not included in scope of delivery
2	Thread reach max. 10 mm
3	Thread reach max. 5 mm
4	Connection line PVC AWG20, connector housing 3-pole tyco 2178473-2, 3x plug pin tyco 926885-1
4.1	N (blue)
4.2	PE (green/yellow)
4.3	L (black)
5	Connection line PVC AWG22, 4-pole connector housing Molex 43645-0400, 4x female connector Molex 43235-0001
5.1	GND (blue)
5.2	0-10 V PWM (yellow)
5.3	not used
5.4	Tach (white)

Accessory part

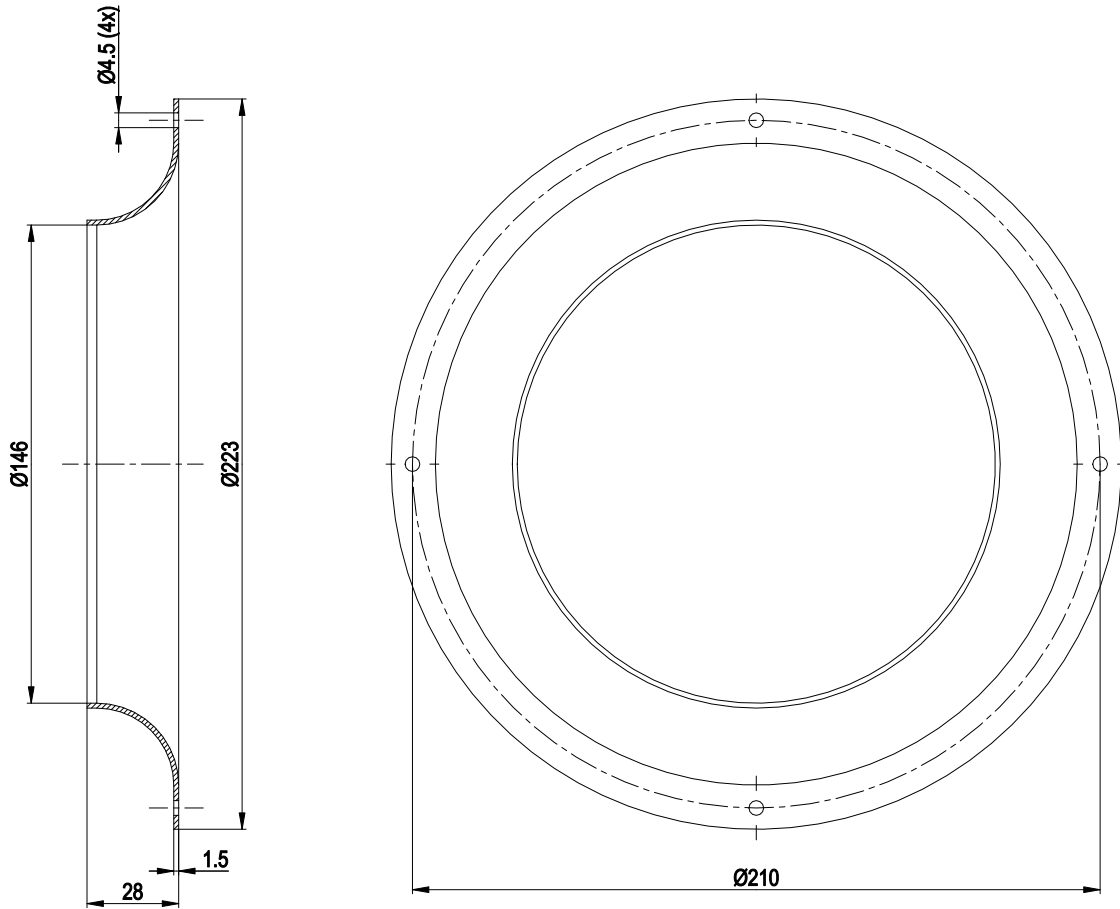

1 Accessory part: Inlet nozzle 96358-2-4013 not included in scope of delivery

EC centrifugal fan

backward curved, single inlet

Connection screen

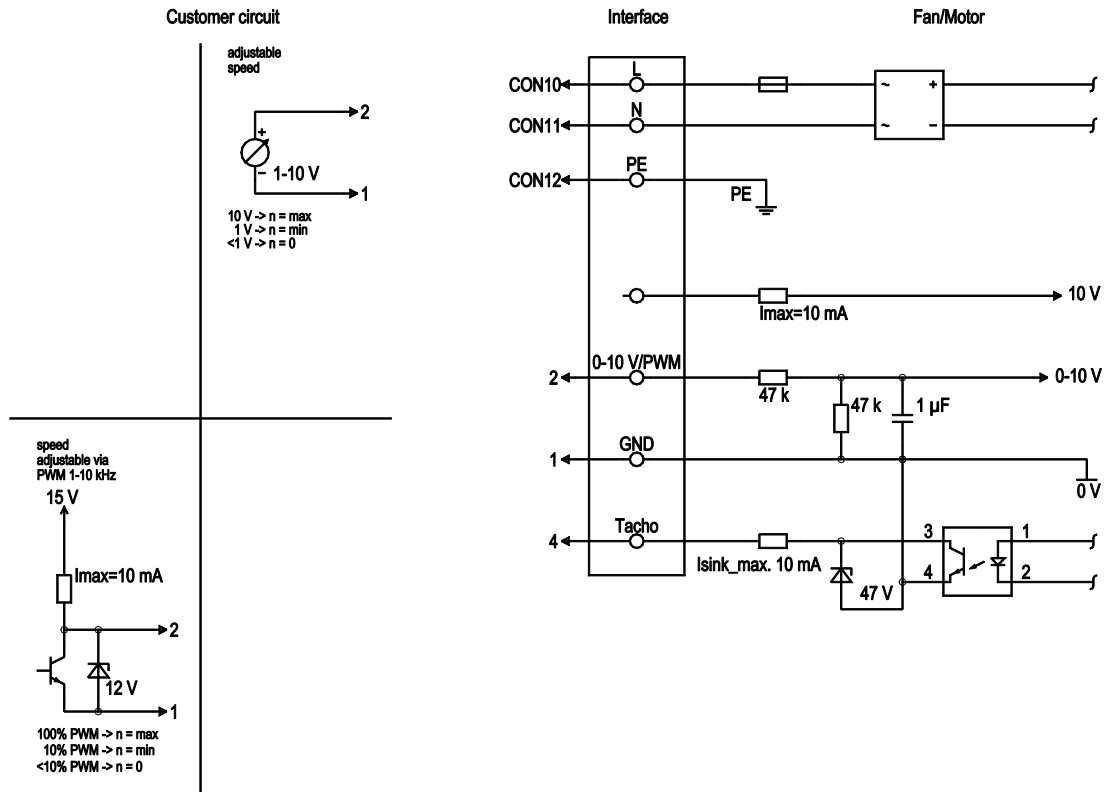

No.	Conn.	Designation	Colour	Function / assignment
	CON10	L	black	Mains connection, power supply, phase, see type plate for voltage range
	CON11	N	blue	Mains connection, power supply, neutral conductor, see type plate for voltage range
	CON12	PE	green/yellow	Earth connection
	2	0- 10V PWM	yellow	0-10 V/PWM control input, R _i =100 kΩ, SELV
	4	Tach	white	Speed monitoring output, open collector, 1 pulse per revolution, I _{sink max} = 10 mA, SELV
	1	GND	blue	Signal ground for control interface, SELV



Charts: Air flow 50 Hz

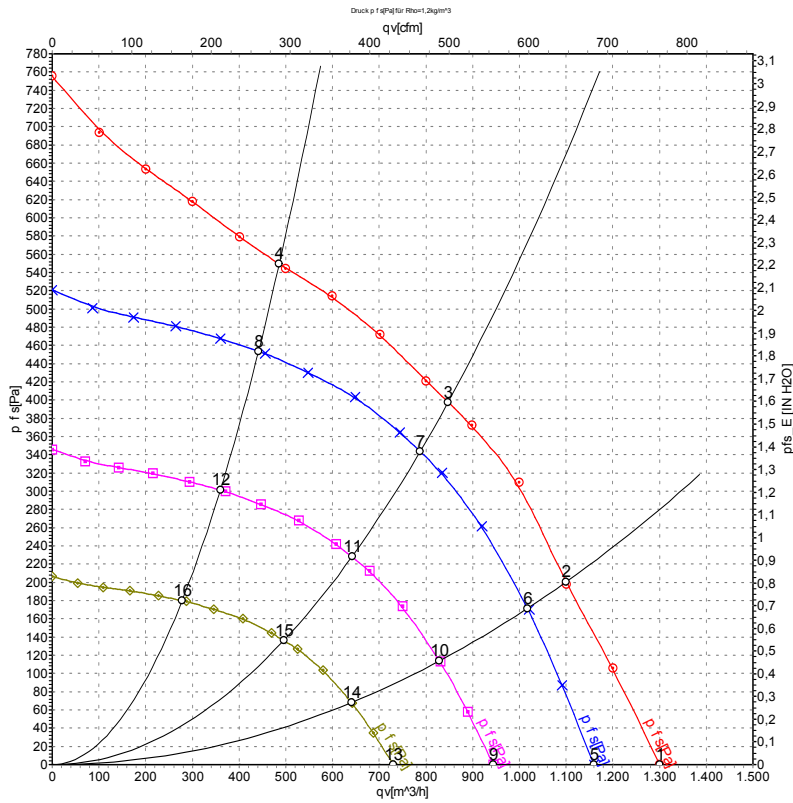

Measurement: LU-129100-1

Air performance measured as per ISO 5801 Installation category A. For detailed information on the measuring set-up, please contact ebmpapst. Suction-side noise levels: L_{wA} measured as per ISO 13347 / L_{pA} measured with 1m distance to fan axis. The values given are valid under the measuring conditions mentioned above and may vary according to the actual installation situation. With any deviation from the standard set-up, the specific values have to be checked and reviewed with the unit installed.

Measured values

	U	f	n	P _{ed}	I	LpA _{in}	LwA _{in}	q _v	P _{fs}	q _v	P _{fs}
	V	Hz	min ⁻¹	W	A	dB(A)	dB(A)	m ³ /h	Pa	cfm	inH ₂ O
1	230	50	3030	151	1.25	70	78	1300	0	765	0.00
2	230	50	2910	168	1.40	66	74	1100	200	645	0.80
3	230	50	2860	170	1.40	60	68	850	400	500	1.61
4	230	50	2970	157	1.35	65	73	485	550	285	2.21
5	230	50	2700	107	0.89	68	76	1160	0	680	0.00
6	230	50	2700	134	1.11	65	72	1015	174	600	0.70
7	230	50	2700	135	1.15	59	67	790	344	465	1.38
8	230	50	2700	118	1.01	62	70	440	454	260	1.82
9	230	50	2200	58	0.48	63	70	945	0	555	0.00
10	230	50	2200	73	0.60	59	67	830	115	490	0.46
11	230	50	2200	73	0.62	54	62	640	228	380	0.92
12	230	50	2200	64	0.55	57	65	360	301	210	1.21
13	230	50	1700	27	0.22	56	64	730	0	430	0.00
14	230	50	1700	33	0.28	53	61	640	69	375	0.28
15	230	50	1700	34	0.29	48	56	495	136	290	0.55
16	230	50	1700	29	0.25	50	59	280	180	165	0.72

U = Supply voltage · f = Frequency · n = Speed (rpm) · P_{ed} = Power input · I = Current draw · LpA_{in} = Sound pressure level inlet side · LwA_{in} = Sound power level inlet side · q_v = Air flow
 P_{fs} = Pressure increase

