

R3G225-AK50-11 ebmpapst Datasheet

sales@fansco.com

www.fansco.com

Limited partnership · Headquarters Muldingen  
County court Stuttgart · HRA 590344

General partner Elektrobau Muldingen GmbH · Headquarters Muldingen  
County court Stuttgart · HRB 590142

## Nominal data

Type	R3G225-AK50-11	
Motor	M3G074-CF	
Phase		1~
Nominal voltage	VAC	230
Frequency	Hz	50/60
Type of data definition		ml
Speed (rpm)	min <sup>-1</sup>	3100
Power input	W	150
Current draw	A	1.25
Min. ambient temperature	°C	-25
Max. ambient temperature	°C	50

ml = Max. load · me = Max. efficiency · fa = Running at free air · cs = Customer specs · cu = Customer unit  
Subject to alterations

## Data according to ErP directive

		Actual	Request 2015			
01 Overall efficiency $\eta_{es}$	%	61	42.5	09 Power input $P_{ed}$	kW	0.14
02 Measurement category		A		09 Air flow $q_v$	m <sup>3</sup> /h	805
03 Efficiency category		Static		09 Pressure increase $p_{fs}$	Pa	347
04 Efficiency grade N		80.5	62	10 Speed (rpm) n	min <sup>-1</sup>	3105
05 Variable speed drive		Yes		11 Specific ratio*		1.00

Data definition with optimum efficiency.  
The ErP data is determined using a motor-impeller combination in a standardised measurement configuration.

\* Specific ratio =  $1 + p_s / 100\,000\text{ Pa}$

LU-175245



### Technical features

Mass	3.9 kg
Size	225 mm
Surface of rotor	Thick layer passivated
Material of impeller	Sheet steel, galvanised
Material of mounting plate	Sheet steel, galvanised
Number of blades	7
Direction of rotation	Clockwise, seen on rotor
Type of protection	IP 44
Insulation class	"B"
Humidity (F)/environmental protection class (H)	F3-1
Max. permissible ambient motor temp. (transp./ storage)	+ 80 °C
Min. permissible ambient motor temp. (transp./storage)	- 40 °C
Mounting position	Any
Condensate discharge holes	None
Operation mode	S1
Motor bearing	Ball bearing
Technical features	<ul style="list-style-type: none"> <li>- Output 10 VDC, max. 1.1 mA</li> <li>- Tach output</li> <li>- Output limit</li> <li>- Motor current limit</li> <li>- Soft start</li> <li>- Control input 0-10 VDC / PWM</li> <li>- Control interface with SELV potential safely disconnected from the mains</li> <li>- Over-temperature protected motor</li> </ul>
Touch current acc. IEC 60990 (measuring network Fig. 4, TN system)	<= 3.5 mA
Motor protection	Thermal overload protector (TOP) wired internally
Cable exit	Variable
Protection class	I (if protective earth is connected by customer)
Product conforming to standard	EN 60335-1; CE

## Product drawing

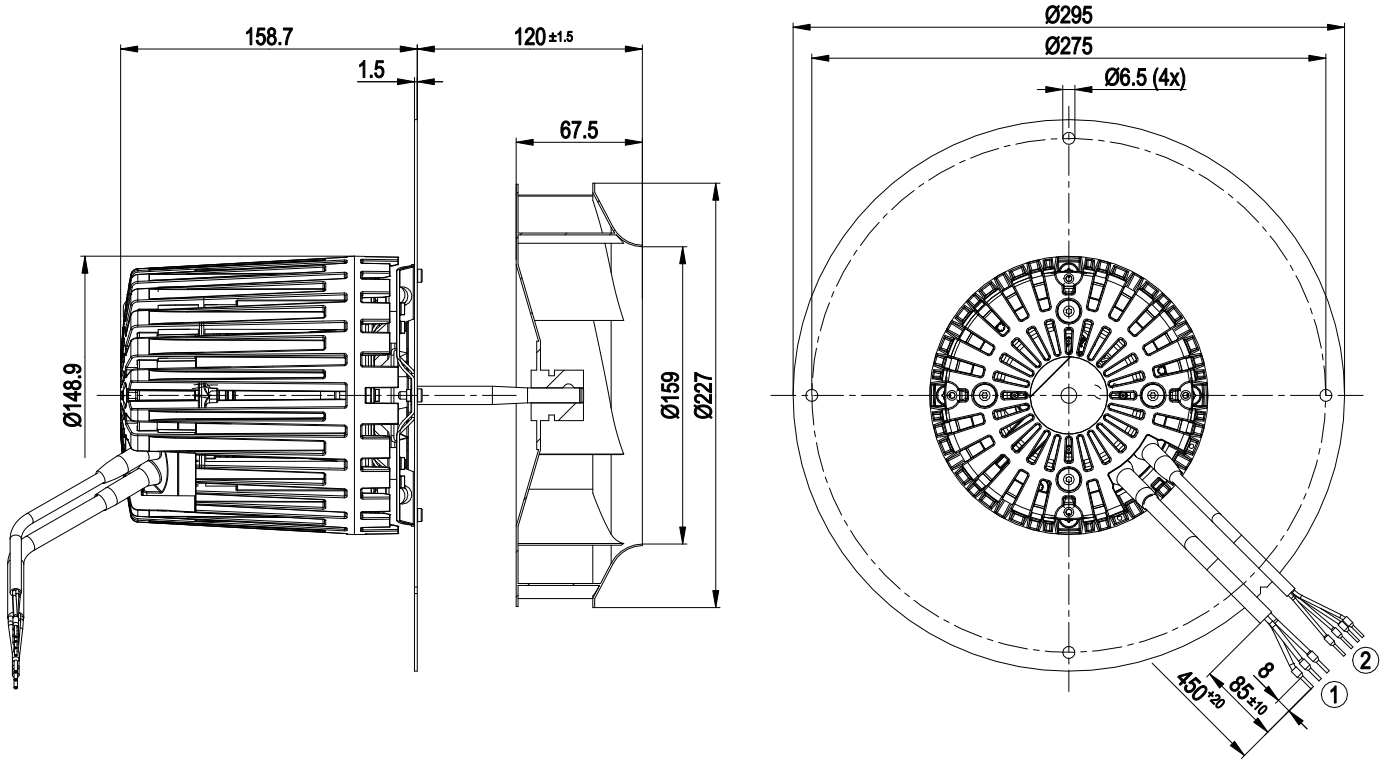

- 1 Connection line PVC AWG18, 3x crimped core-end sleeves
- 2 Connection line PVC AWG22, 4x crimped core-end sleeves

## Connection screen

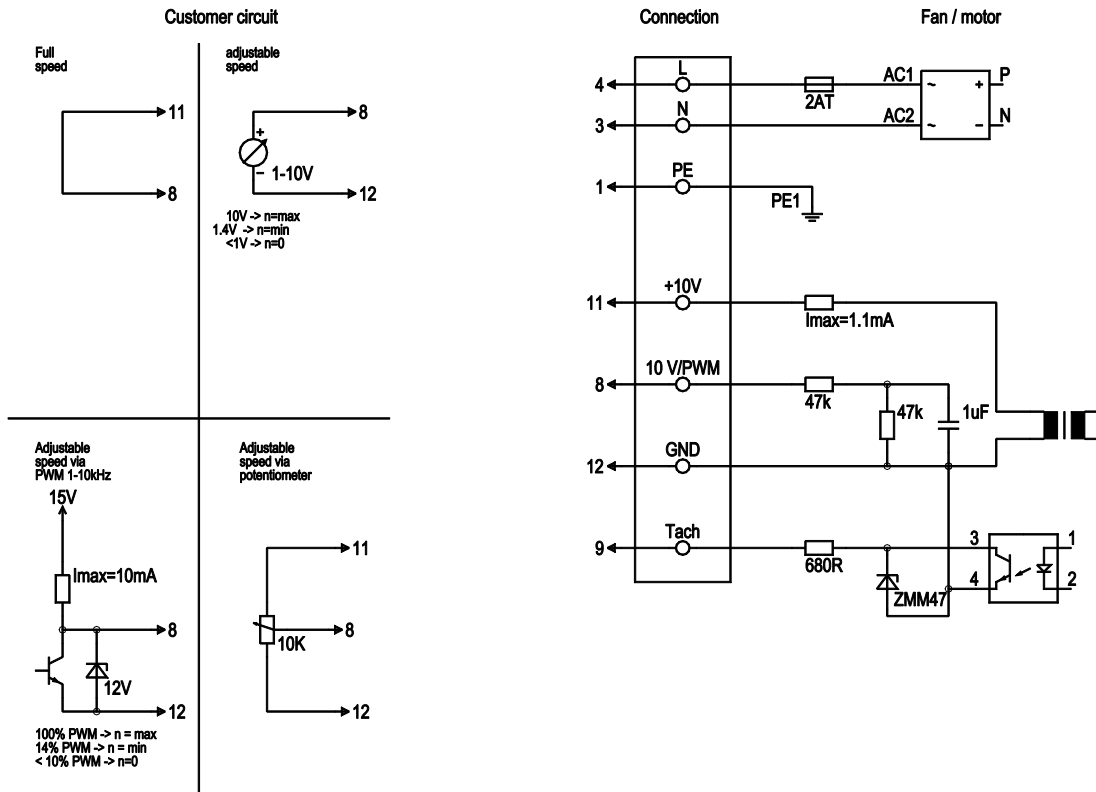

No.	Conn.	Designation	Colour	Function / assignment
	4	L	black	Power supply 230 VAC, 50-60 Hz, see type plate for voltage range
	3	N	blue	Neutral conductor
	1	PE	green/yellow	Protective earth
	8	0-10 V PWM	yellow	Control input 0 - 10 V or PWM, electrically isolated
	9	Tach	white	Tach output: open collector, 1 pulse per revolution, electrically isolated
	11	10V / max 1.1 mA	red	Voltage output 10 V / max. 1.1 mA, electrically isolated
	12	GND	blue	GND - Connection for control interface

## Charts: Air flow 50 Hz

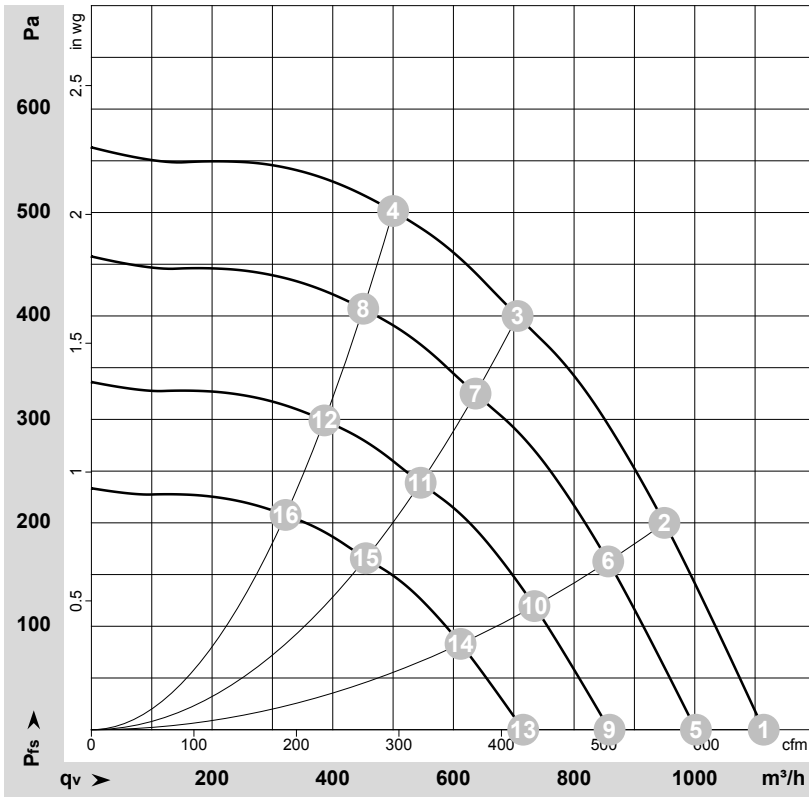

$\rho = 1.15 \text{ kg/m}^3 \pm 2 \%$

Measurement: LU-175245-1

Air performance measured as per ISO 5801 Installation category A. For detailed information on the measuring set-up, please contact ebmpapst. Suction-side noise levels: LwA measured as per ISO 13347 / LpA measured with 1m distance to fan axis. The values given are valid under the measuring conditions mentioned above and may vary according to the actual installation situation. With any deviation from the standard set-up, the specific values have to be checked and reviewed with the unit installed.

## Measured values

	U	f	n	P <sub>ed</sub>	I	LpA <sub>in</sub>	LwA <sub>in</sub>	q <sub>v</sub>	P <sub>fs</sub>	q <sub>v</sub>	P <sub>fs</sub>
	V	Hz	min <sup>-1</sup>	W	A	dB(A)	dB(A)	m <sup>3</sup> /h	Pa	cfm	inH <sub>2</sub> O
1	230	50	3100	84	0.71	69	79	1115	0	655	0.00
2	230	50	3100	123	1.01	65	73	950	200	560	0.80
3	230	50	3100	150	1.25	62	70	705	400	415	1.61
4	230	50	3100	148	1.21	65	74	500	500	295	2.01
5	230	50	2800	61	0.51	67	76	1000	0	590	0.00
6	230	50	2800	91	0.74	63	71	855	163	505	0.65
7	230	50	2800	111	0.90	60	67	635	324	375	1.30
8	230	50	2800	108	0.88	62	72	450	408	265	1.64
9	230	50	2400	38	0.32	63	72	860	0	505	0.00
10	230	50	2400	57	0.47	59	67	735	120	430	0.48
11	230	50	2400	70	0.56	56	63	545	238	320	0.96
12	230	50	2400	68	0.56	58	68	385	300	225	1.20
13	230	50	2000	22	0.19	58	68	715	0	420	0.00
14	230	50	2000	33	0.27	54	62	610	83	360	0.33
15	230	50	2000	40	0.33	51	59	455	166	270	0.67
16	230	50	2000	39	0.32	54	63	320	208	190	0.84

U = Supply voltage · f = Frequency · n = Speed (rpm) · P<sub>ed</sub> = Power input · I = Current draw · LpA<sub>in</sub> = Sound pressure level inlet side · LwA<sub>in</sub> = Sound power level inlet side · q<sub>v</sub> = Air flow  
P<sub>fs</sub> = Pressure increase

