

R3G225-AF16-12

EC centrifugal fan

backward curved, single inlet

for railway applications

R3G225-AF16-12 ebmpapst Datasheet FansCo

sales@fansco.com

www.fansco.com

Nominal data

Type	R3G225-AF16-12	
Motor	M3G074-BF	
Nominal voltage	VDC	24
Nominal voltage range	VDC	16 .. 34
Type of data definition		fa
Speed (rpm)	min ⁻¹	2750
Power input	W	86
Current draw	A	3.6
Min. ambient temperature	°C	-25
Max. ambient temperature	°C	50

ml = Max. load · me = Max. efficiency · fa = Running at free air · cs = Customer specs · cu = Customer unit
Subject to alterations



EC centrifugal fan

backward curved, single inlet
for railway applications

Technical features

Mass	1.5 kg
Size	225 mm
Surface of rotor	Coated in black
Material of impeller	Plastic PA66, fibreglass-reinforced, round sheet-metal plate coated in black
Number of blades	11
Direction of rotation	Clockwise, seen on rotor
Type of protection	IP 24 KM
Insulation class	"B"
Humidity (F)/environmental protection class (H)	H3
Max. permissible ambient motor temp. (transp./ storage)	+ 80 °C
Min. permissible ambient motor temp. (transp./storage)	- 40 °C
Mounting position	Shaft horizontal or rotor on bottom; rotor on top on request
Condensate discharge holes	None
Operation mode	S1
Motor bearing	Ball bearing
Technical features	<ul style="list-style-type: none"> - Control input 0-10 VDC / PWM - Tach output - Motor current limit - Soft start
EMC directives	EN 50121-3-2; EN 50155
Motor protection	Locked-rotor protection
Cable exit	Lateral



EC centrifugal fan

backward curved, single inlet

for railway applications

Product drawing

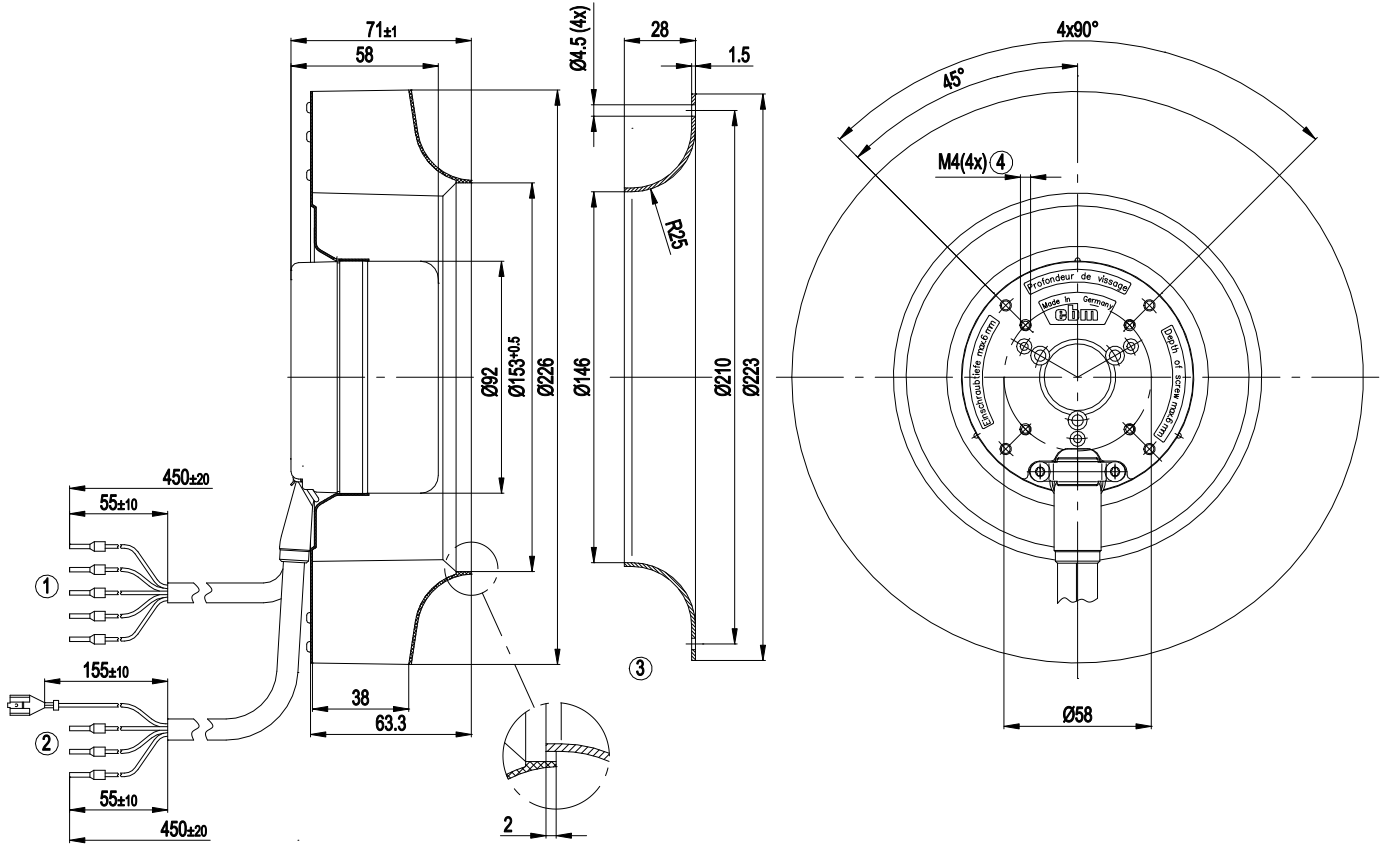

1	Connection line silicone 5 x 0.5 mm, 5 x brass lead tips crimped
2	Connection line silicone 4 x 1.5 mm, 3x crimped core-end sleeves and 1x crimped receptacle for tabs 6.3 x 0.8
3	Accessory part: Inlet nozzle 96358-2-4013, not included in the standard scope of delivery
4	Accessory part: External electronics CHG032-AA01-01 not included in the standard scope of delivery
5	Depth of screw max. 6 mm



EC centrifugal fan

backward curved, single inlet
for railway applications

Connection screen

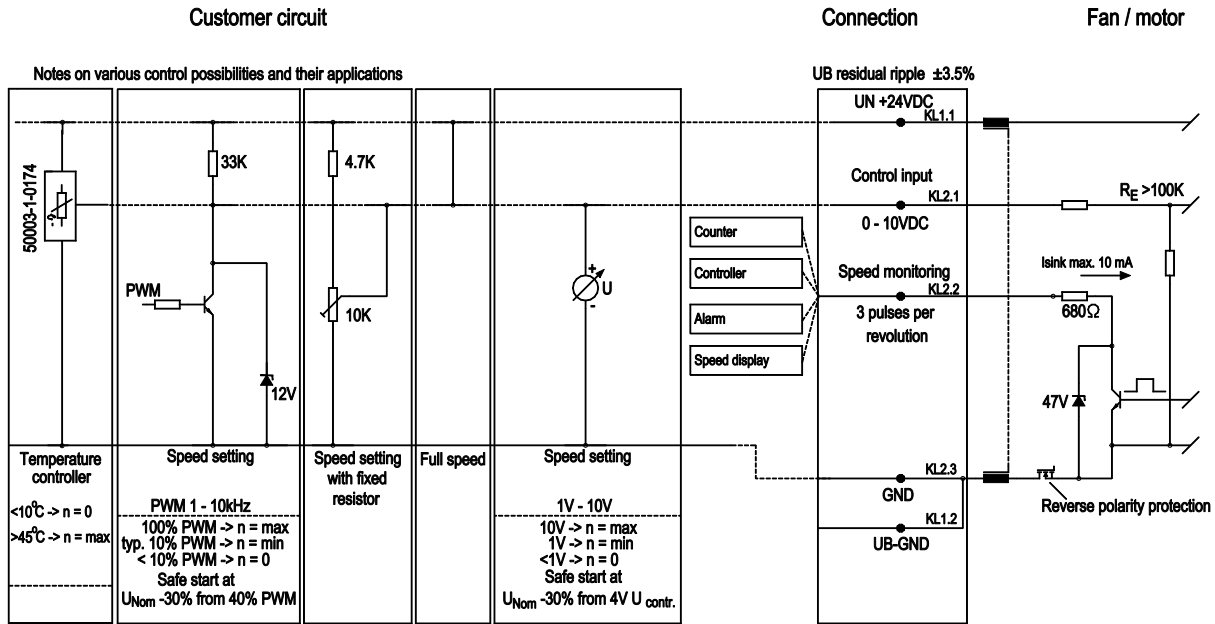

Pin configuration for external electronics: CHG032AA0101

Customer interface

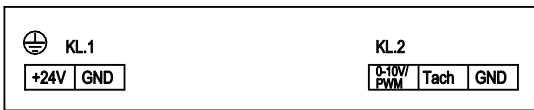

Motor interface

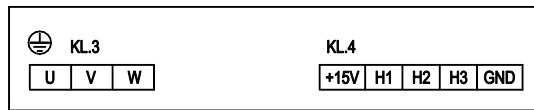

No.	Conn.	Designation	Function / assignment
KL.3		+15V	red
KL.3		GND	blue
KL.3		H1	orange
KL.3		H2	brown
KL.3		H3	yellow
KL.4		U	black
KL.4		V	blue
KL.4		W	brown
PE		PE	green/yellow



Charts: Air flow

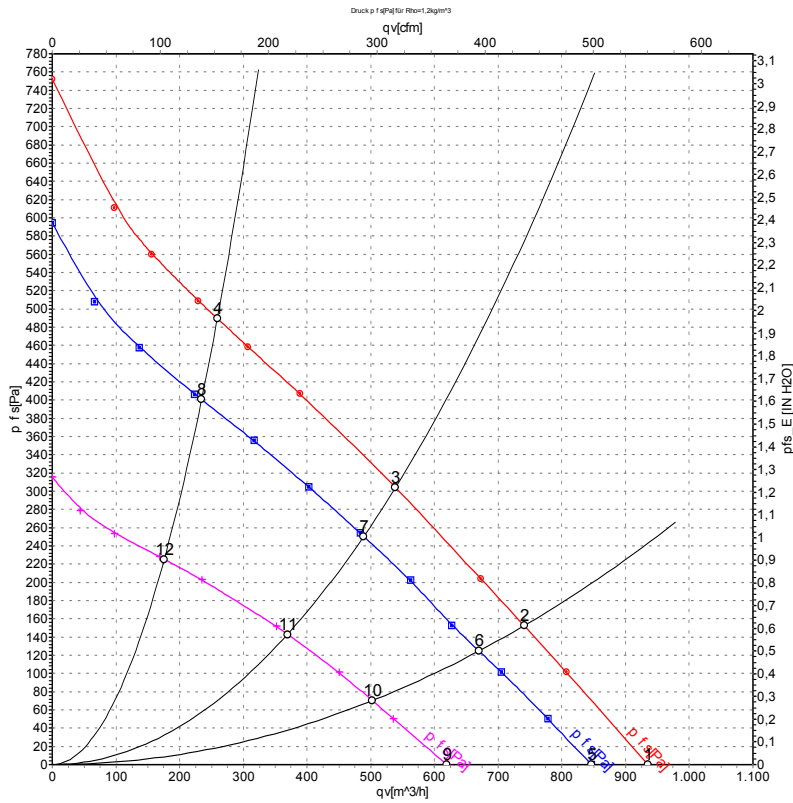

Measurement: LU-39148-1
 Measurement: LU-39146-1
 Measurement: LU-39145-1

Air performance measured as per ISO 5801 Installation category A. For detailed information on the measuring set-up, please contact ebmpapst. Suction-side noise levels: L_{WA} measured as per ISO 13347 / L_{pA} measured with 1m distance to fan axis. The values given are valid under the measuring conditions mentioned above and may vary according to the actual installation situation. With any deviation from the standard set-up, the specific values have to be checked and reviewed with the unit installed.

Measured values

	U	n	P _{ed}	I	q _v	p _{fs}	q _v	p _{fs}
	V	min ⁻¹	W	A	m ³ /h	Pa	cfm	inH ₂ O
1	28	3015	118	4.24	935	0	550	0.00
2	28	2890	129	4.60	740	152	435	0.61
3	28	2840	132	4.74	540	305	315	1.22
4	28	3015	119	4.27	260	490	150	1.97
5	24	2750	86	3.60	845	0	500	0.00
6	24	2610	94	3.93	670	125	395	0.50
7	24	2580	97	4.03	490	250	290	1.00
8	24	2720	87	3.62	235	400	140	1.61
9	16	2035	36	2.26	620	0	365	0.00
10	16	1975	40	2.50	505	70	295	0.28
11	16	1955	41	2.58	370	143	215	0.57
12	16	2035	37	2.29	175	225	105	0.90

U = Supply voltage · n = Speed (rpm) · P_{ed} = Power input · I = Current draw · q_v = Air flow · p_{fs} = Pressure increase

