

R3G225-AE17-11

EC centrifugal fan

backward-curved



R3G225-AE17-11 ebmpapst Datasheet

sales@fansco.com

www.fansco.com

Limited partnership · Headquarters Mulfingen

Amtsgericht (court of registration) Stuttgart · HRA 590344

General partner Elektrobau Mulfingen GmbH · Headquarters Mulfingen

Amtsgericht (court of registration) Stuttgart · HRB 590142

Nominal data

Type	R3G225-AE17-11	
Motor	M3G055-CF	
Phase		1~
Nominal voltage	VAC	230V
Frequency	Hz	50/60
Method of obtaining data		ml
Speed (rpm)	min ⁻¹	2200
Power consumption	W	60
Current draw	A	0.42
Min. ambient temperature	°C	-25
Max. ambient temperature	°C	50

ml = Max. load · me = Max. efficiency · fa = Free air · cs = Customer specification · ce = Customer equipment
Subject to change



Technical description

Weight	1.5 kg
Fan size	225 mm
Rotor surface	Thick-film passivated
Electronics housing material	Die-cast aluminum
Impeller material	PA plastic
Number of blades	7
Direction of rotation	Clockwise, viewed toward rotor
Degree of protection	IP44
Insulation class	"B"
Moisture (F) / Environmental (H) protection class	F3-1
Max. permitted ambient temp. for motor (transport/storage)	+ 80 °C
Min. permitted ambient temp. for motor (transport/storage)	- 40 °C
Installation position	Any
Condensation drainage holes	On rotor side
Mode	S1
Motor bearing	Ball bearing
Technical features	<ul style="list-style-type: none"> - Tach output - Motor current limitation - Soft start - PWM control input
EMC immunity to interference	According to EN 61000-6-2 (industrial environment)
EMC circuit feedback	According to EN 61000-3-2/3
EMC interference emission	According to EN 61000-6-3 (household environment)
Touch current according to IEC 60990 (measuring circuit Fig. 4, TN system)	<= 3.5 mA
Electrical hookup	With plug
Motor protection	Locked-rotor protection
With cable	Variable
Protection class	I (with customer connection of protective earth)
Approval	CCC; UL 507

Product drawing

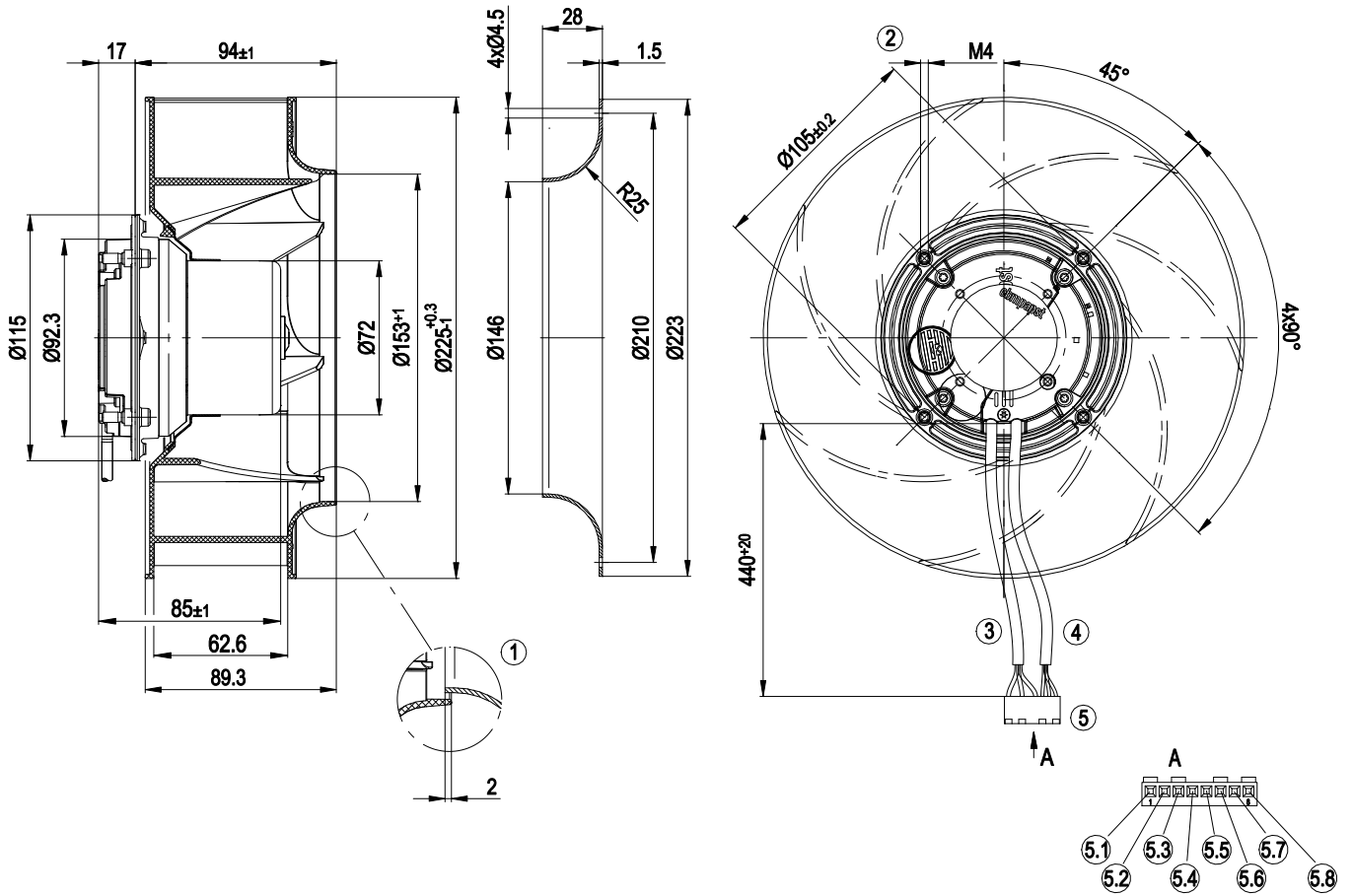

1	Accessory part: inlet ring 96358-2-4013 not included in scope of delivery
2	Thread on threaded pin: 10-24 UNC
3	Cable AWG20 UL-Style 2517, 3 x plug pin Molex 08-50-0105 crimped
4	Cable AWG22 UL-Style 2464, 3 x plug pin Molex 08-50-0105 crimped
5	Connector housing Molex 09-50-8081
5.1	AC 230 V/115 V (brown)
5.2	N.C. (not used)
5.3	AC neutral (blue)
5.4	N.C. (not used)
5.5	PE (green/yellow)
5.6	Open-loop speed control (yellow)
5.7	Tach output (white)
5.8	GND (blue)

Connection diagram

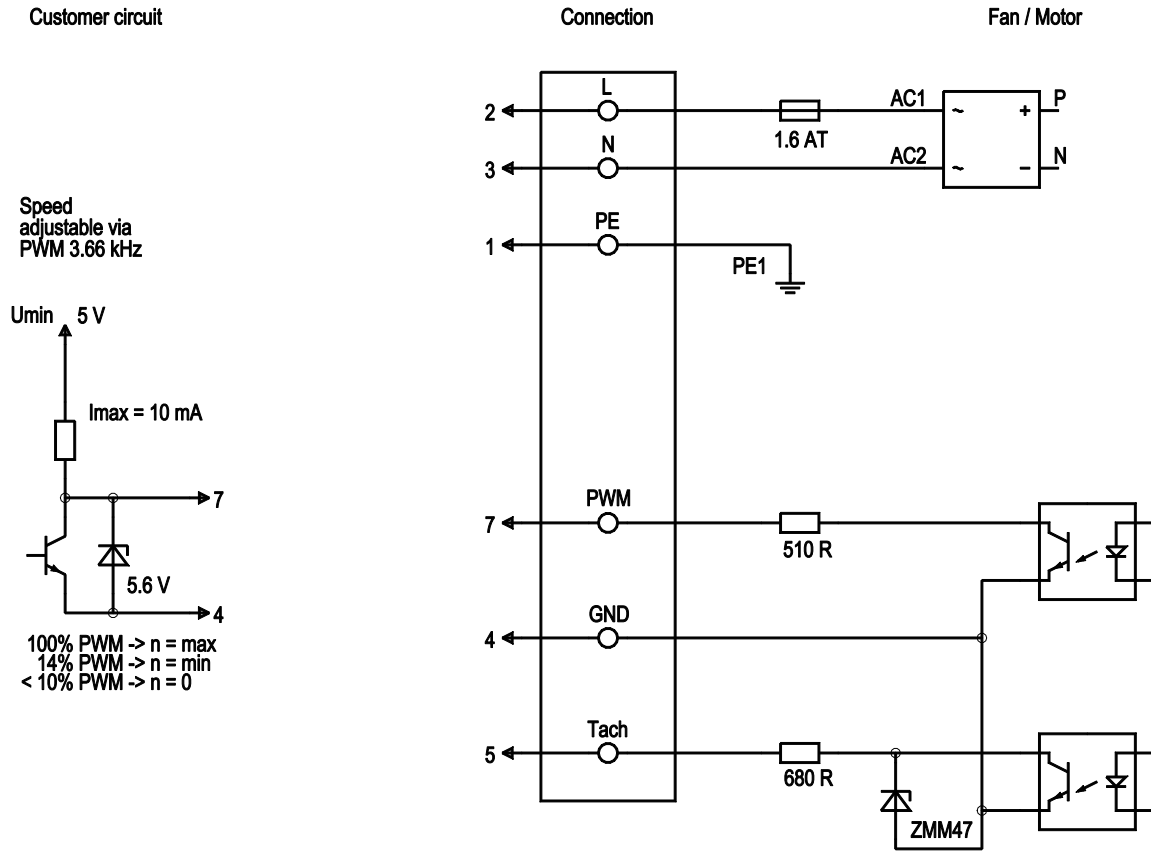

No.	Conn.	Designation	Color	Function/assignment
1	PE		green/yellow	Protective earth
2	L		brown	Power supply 230 VAC, 50 - 60 Hz
3	N		blue	Neutral conductor
4	GND		blue	GND connection for control interface
5	Tach		white	Tach output: Open collector, 1 pulse per revolution, electrically isolated
7	PWM		yellow	Control input PWM, electrically isolated

Curves: Air performance 50 Hz

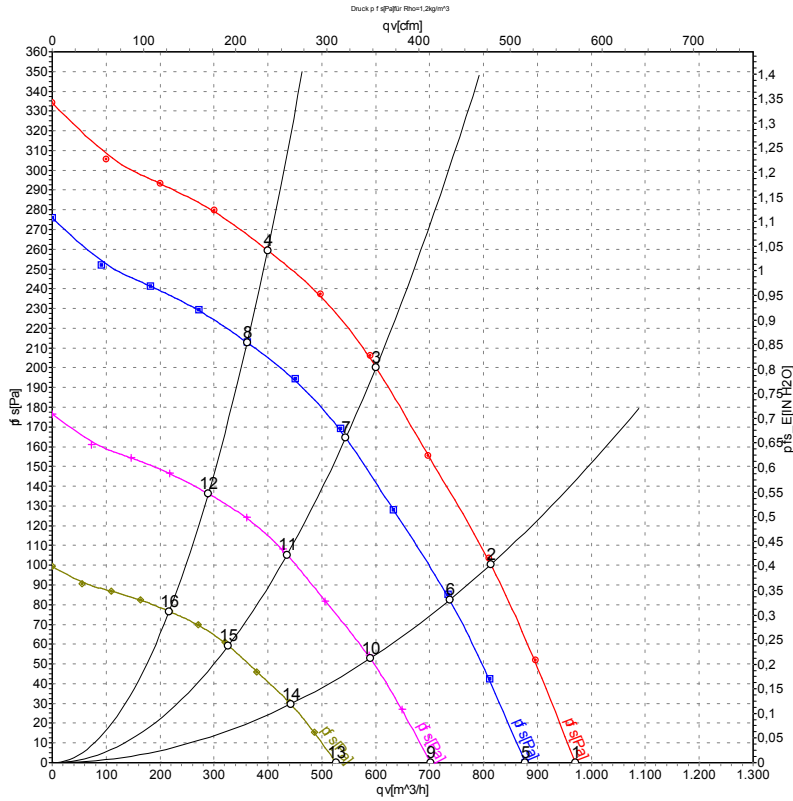

Measurement: LU-68528-1

Air performance measured according to ISO 5801 installation category A. For detailed information on the measurement setup, contact ebmpapst. Intake sound level: Sound power level according to ISO 13347 / sound pressure level measured at 1 m distance from fan axis. The values given are valid under the specified measuring conditions and may vary due to conditions of installation. For deviations from the standard configuration, the parameters have to be checked on the installed unit.

Measured values

	U	f	n	P _{ed}	I	qv	p _{fs}	qv	p _{fs}
	V	Hz	min ⁻¹	W	A	m ³ /h	Pa	CFM	inH2O
1	230	50	2200	60	0.42	970	0	570	0.00
2	230	50	2200	71	0.53	815	100	480	0.40
3	230	50	2200	80	0.62	600	200	355	0.80
4	230	50	2200	75	0.57	400	260	235	1.04
5	230	50	2000	43	0.32	875	0	515	0.00
6	230	50	2000	53	0.40	735	84	435	0.34
7	230	50	2000	60	0.46	545	165	320	0.66
8	230	50	2000	56	0.43	360	213	215	0.86
9	230	50	1600	22	0.16	700	0	415	0.00
10	230	50	1600	27	0.20	590	54	345	0.22
11	230	50	1600	31	0.24	435	106	255	0.43
12	230	50	1600	29	0.22	290	136	170	0.55
13	230	50	1200	9.3	0.07	525	0	310	0.00
14	230	50	1200	11	0.09	440	30	260	0.12
15	230	50	1200	13	0.10	325	60	190	0.24
16	230	50	1200	12	0.09	215	77	130	0.31

U = Power supply · f = Frequency · n = Speed (rpm) · P_{ed} = Power consumption · I = Current draw · qv = Air flow · p_{fs} = Pressure increase

