

R3G225-AE11-23

# EC centrifugal fan

backward-curved



R3G225-AE11-23 ebmpapst Datasheet

[sales@fansco.com](mailto:sales@fansco.com)

[www.fansco.com](http://www.fansco.com)

Limited partnership · Headquarters Mulfingen

Amtsgericht (court of registration) Stuttgart · HRA 590344

General partner Elektrobau Mulfingen GmbH · Headquarters Mulfingen

Amtsgericht (court of registration) Stuttgart · HRB 590142

## Nominal data

Type	R3G225-AE11-23	
Motor	M3G055-CF	
Phase		1~
Nominal voltage	VAC	230
Frequency	Hz	50/60
Method of obtaining data		ml
Speed (rpm)	min <sup>-1</sup>	2290
Power consumption	W	95
Current draw	A	0.75
Min. ambient temperature	°C	-25
Max. ambient temperature	°C	60

ml = Max. load · me = Max. efficiency · fa = Free air · cs = Customer specification · ce = Customer equipment  
Subject to change



## Technical description

Weight	1.6 kg
Fan size	225 mm
Rotor surface	Thick-film passivated
Electronics housing material	Die-cast aluminum
Impeller material	PA plastic
Number of blades	7
Direction of rotation	Clockwise, viewed toward rotor
Degree of protection	IP44
Insulation class	"B"
Moisture (F) / Environmental (H) protection class	F3-1
Max. permitted ambient temp. for motor (transport/storage)	+ 80 °C
Min. permitted ambient temp. for motor (transport/storage)	- 40 °C
Installation position	Shaft horizontal or rotor on bottom; rotor on top on request
Condensation drainage holes	None, open rotor
Mode	S1
Motor bearing	Ball bearing
Technical features	<ul style="list-style-type: none"> <li>- Output 10 VDC, max. 1.1 mA</li> <li>- Tach output</li> <li>- Motor current limitation</li> <li>- Soft start</li> <li>- Control input 0-10 VDC / PWM</li> <li>- Control interface with SELV potential safely disconnected from the mains</li> <li>- Thermal overload protection for motor</li> </ul>
EMC immunity to interference	According to EN 61000-6-2 (industrial environment)
EMC circuit feedback	According to EN 61000-3-2/3
EMC interference emission	According to EN 61000-6-3 (household environment)
Touch current according to IEC 60990 (measuring circuit Fig. 4, TN system)	<= 3.5 mA
Motor protection	Thermal overload protector (TOP) internally connected
With cable	Variable
Protection class	I (with customer connection of protective earth)
Conformity with standards	EN 60335-1

Product drawing

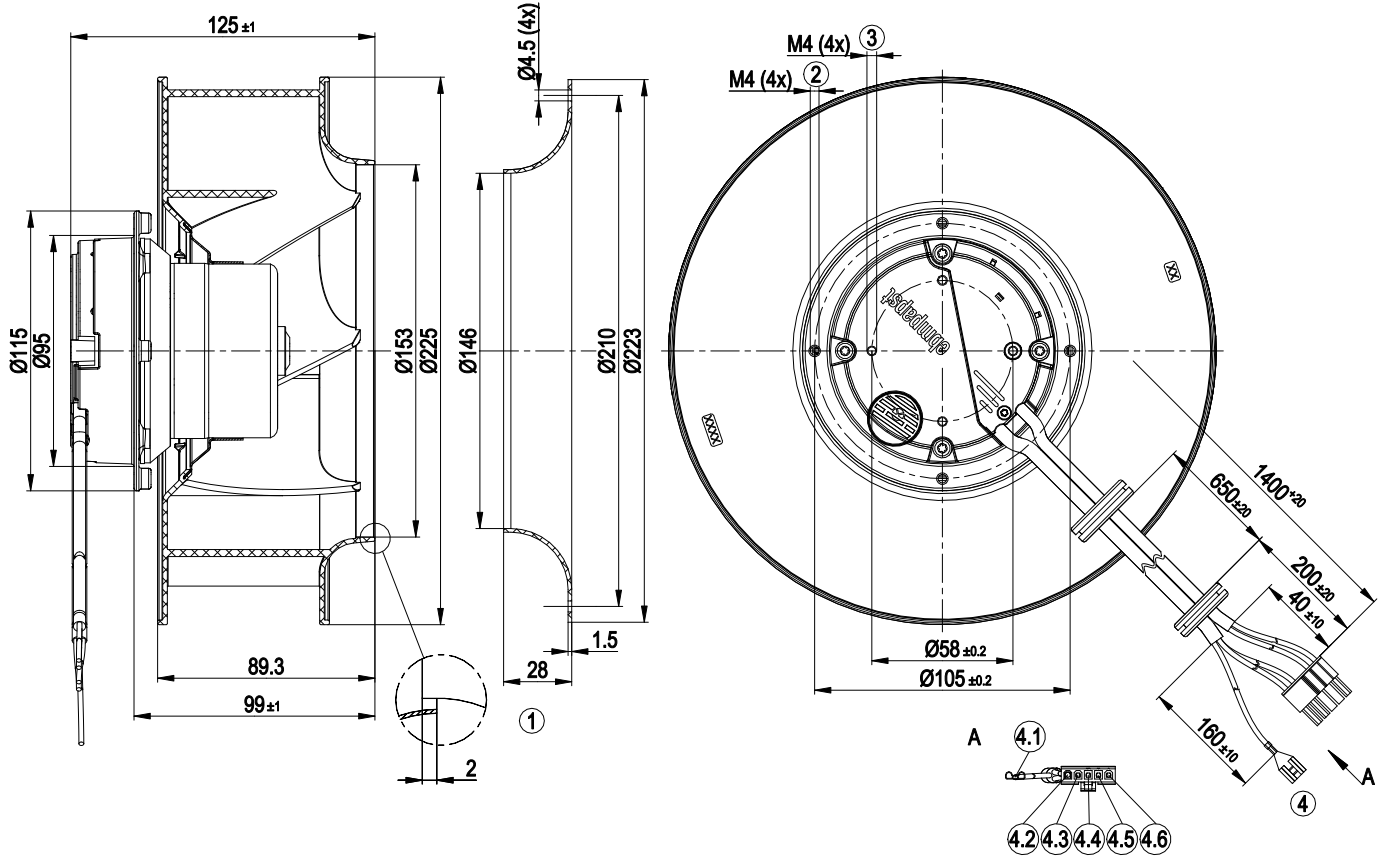

1	Accessory part: inlet ring 96358-2-4013 not included in scope of delivery
2	Max. clearance for screw 6 mm
3	Max. clearance for screw 6 mm
4	Cable PVC 3G 0.5 mm <sup>2</sup> ; 1x flat push-on receptacle 6.3 x 0.8 and Stocko connector housing 705-005-003-960
4.1	PE (green/yellow)
4.2	N (brown)
4.3	L (blue)
4.4	not used
4.5	GND (blue)
4.6	0-10 V (yellow)



## Connection diagram

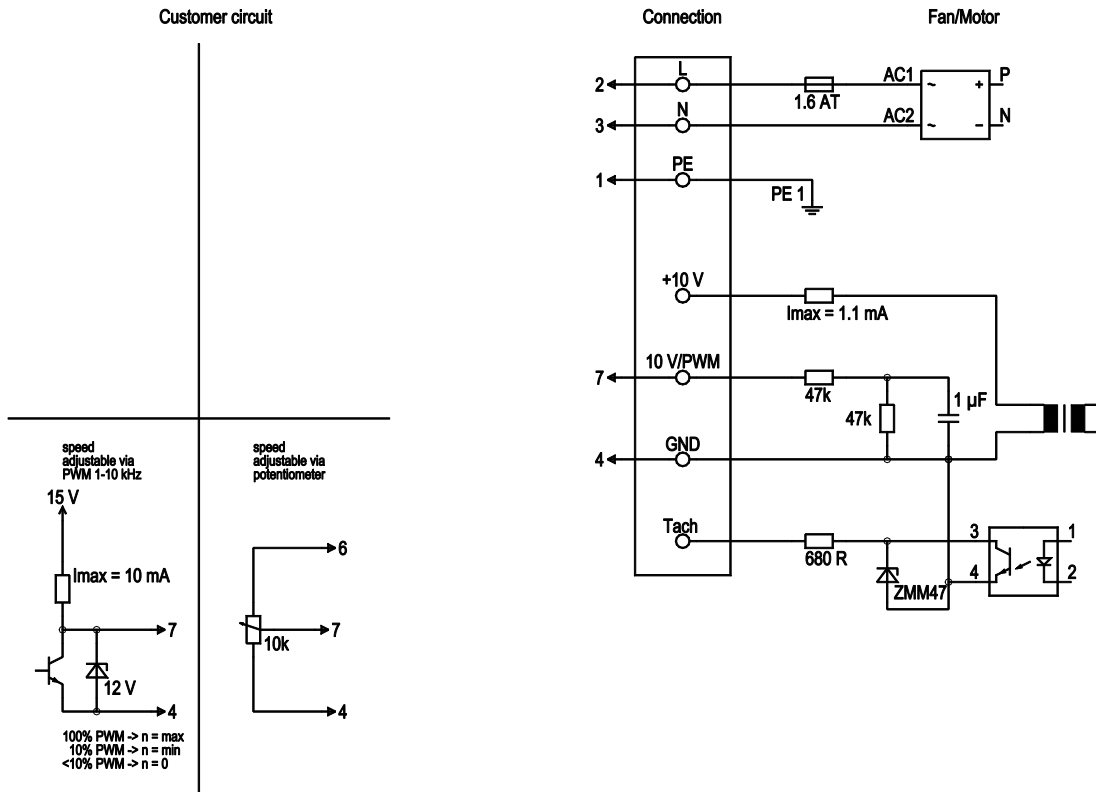

No.	Conn.	Designation	Color	Function/assignment
	1	PE	green/yellow	Protective earth
	2	L	brown	Power supply 230 VAC, 50-60 Hz
	3	N	blue	Neutral conductor
	4	GND	blue	GND connection for control interface
	7	0-10 V PWM	yellow	Control input 0-10 V or PWM, electrically isolated

## Curves: Air performance 50 Hz

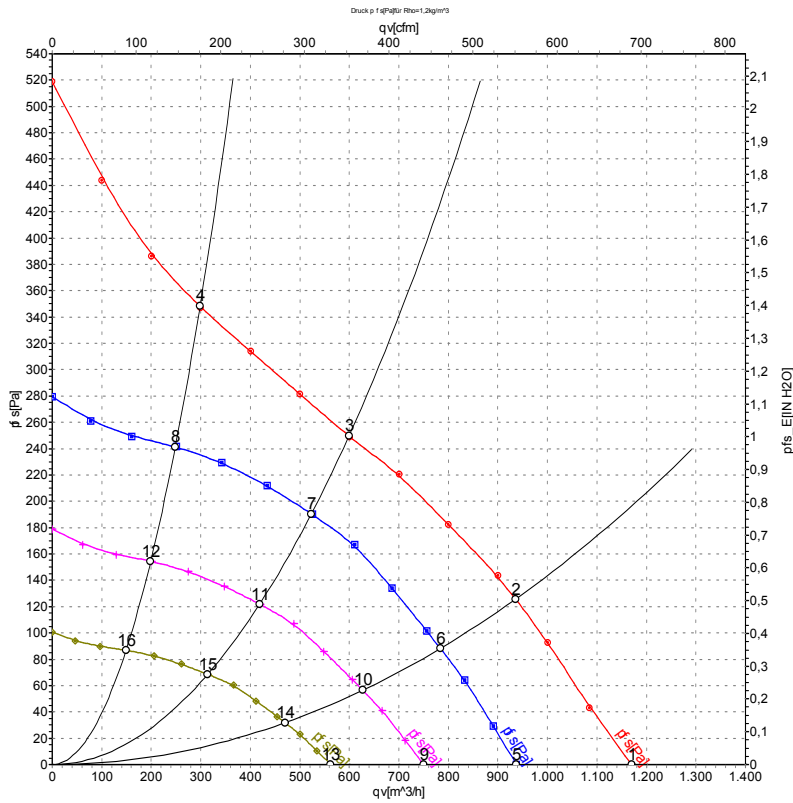

Measurement: LU-77232-1

Air performance measured according to ISO 5801 installation category A. For detailed information on the measurement setup, contact ebmpapst. Intake sound level: Sound power level according to ISO 13347 / sound pressure level measured at 1 m distance from fan axis. The values given are valid under the specified measuring conditions and may vary due to conditions of installation. For deviations from the standard configuration, the parameters have to be checked on the installed unit.

## Measured values

	U	f	n	P <sub>ed</sub>	I	qv	p <sub>fs</sub>	qv	p <sub>fs</sub>
	V	Hz	min <sup>-1</sup>	W	A	m <sup>3</sup> /h	Pa	CFM	inH <sub>2</sub> O
1	230	50	2495	80	0.60	1170	0	690	0.00
2	230	50	2390	87	0.67	935	125	550	0.50
3	230	50	2290	95	0.75	600	250	355	1.00
4	230	50	2400	85	0.66	300	350	175	1.41
5	230	50	2000	41	0.31	940	0	550	0.00
6	230	50	2000	51	0.39	785	88	460	0.35
7	230	50	2000	63	0.48	525	191	310	0.77
8	230	50	2000	49	0.38	250	242	145	0.97
9	230	50	1600	21	0.16	750	0	440	0.00
10	230	50	1600	26	0.20	625	56	370	0.22
11	230	50	1600	32	0.25	420	122	245	0.49
12	230	50	1600	25	0.20	200	155	115	0.62
13	230	50	1200	8.9	0.07	565	0	330	0.00
14	230	50	1200	11	0.08	470	32	275	0.13
15	230	50	1200	14	0.10	315	69	185	0.28
16	230	50	1200	11	0.08	150	87	90	0.35

U = Power supply · f = Frequency · n = Speed (rpm) · P<sub>ed</sub> = Power consumption · I = Current draw · qv = Air flow · p<sub>fs</sub> = Pressure increase

