

R3G220-RD53-19 ebmpapst Datasheet

sales@fansco.com

www.fansco.com

Limited partnership · Headquarters Muldingen

Amtsgericht (court of registration) Stuttgart · HRA 590344

General partner Elektrobau Muldingen GmbH · Headquarters Muldingen

Amtsgericht (court of registration) Stuttgart · HRB 590142

Nominal data

Type	R3G220-RD53-19	
Motor	M3G055-CF	
Phase		1~
Nominal voltage	VAC	230
Nominal voltage range	VAC	200 .. 240
Frequency	Hz	50/60
Method of obtaining data		ml
Speed (rpm)	min ⁻¹	3230
Power consumption	W	168
Current draw	A	1.4
Min. ambient temperature	°C	-25
Max. ambient temperature	°C	50

ml = Max. load · me = Max. efficiency · fa = Free air · cs = Customer specification · ce = Customer equipment
Subject to change

Data according to Commission Regulation (EU) 327/2011 (EN 17166)

		Actual	Req. 2015			
01 Overall efficiency η_{es}	%	56.7	43.3	09 Power consumption P_{ed}	kW	0.16
02 Measurement category		A		09 Air flow q_v	m ³ /h	805
03 Efficiency category		Static		09 Pressure increase p_{fs}	Pa	366
04 Efficiency grade N		75.4	62	10 Speed (rpm) n	min ⁻¹	3210
05 Variable speed drive		Yes		11 Specific ratio [*]		1.00

Data obtained at optimum efficiency level.

The ErP data is determined using a motor-impeller combination in a standardized measurement setup.

^{*} Specific ratio = $1 + p_{fs} / 100\,000\text{ Pa}$

LU-153697



Technical description

Weight	1.4 kg
Size	220 mm
Motor size	55
Rotor surface	Thick-film passivated
Electronics housing material	Die-cast aluminum
Impeller material	PA plastic
Number of blades	7
Direction of rotation	Clockwise, viewed toward rotor
Degree of protection	IP54
Insulation class	"B"
Moisture (F) / Environmental (H) protection class	H1
Max. permitted ambient temp. for motor (transport/storage)	+ 80 °C
Min. permitted ambient temp. for motor (transport/storage)	- 40 °C
Installation position	Any
Condensation drainage holes	None, open rotor
Mode	S1
Motor bearing	Ball bearing
Technical features	<ul style="list-style-type: none"> - Output 10 VDC, max. 10 mA - Tach output - Power limiter - Motor current limitation - Soft start - Control input 0-10 VDC / PWM - Control interface with SELV potential safely disconnected from the mains - Overvoltage detection - Thermal overload protection for electronics/motor - Line undervoltage detection
EMC immunity to interference	According to EN 61000-6-2 (industrial environment)
EMC interference emission	According to EN 61000-6-4 (industrial environment)
Touch current according to IEC 60990 (measuring circuit Fig. 4, TN system)	<= 3.5 mA
Motor protection	Electronic motor protection
With cable	Variable
Protection class	I (with customer connection of protective earth)
Conformity with standards	EN 60034-1; EN 60204-1; EN 60335-1; CE

Product drawing

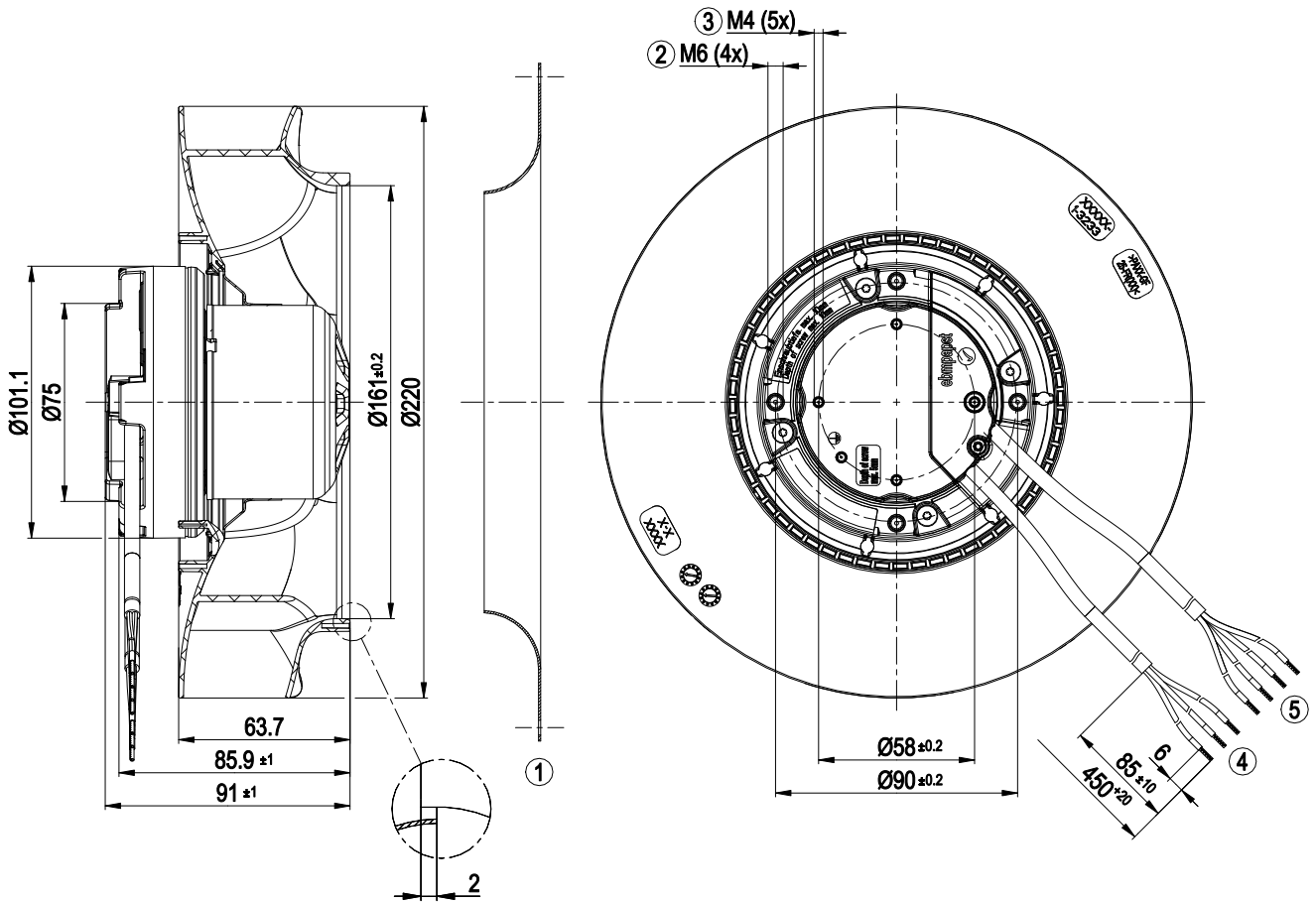

1	Accessory part: inlet ring 09609-2-4013 not included in scope of delivery
2	Max. clearance for screw 10 mm
3	Max. clearance for screw 5 mm
4	Cable PVC AWG20 3x splice
5	Cable PVC AWG22 4x splice



Accessory part

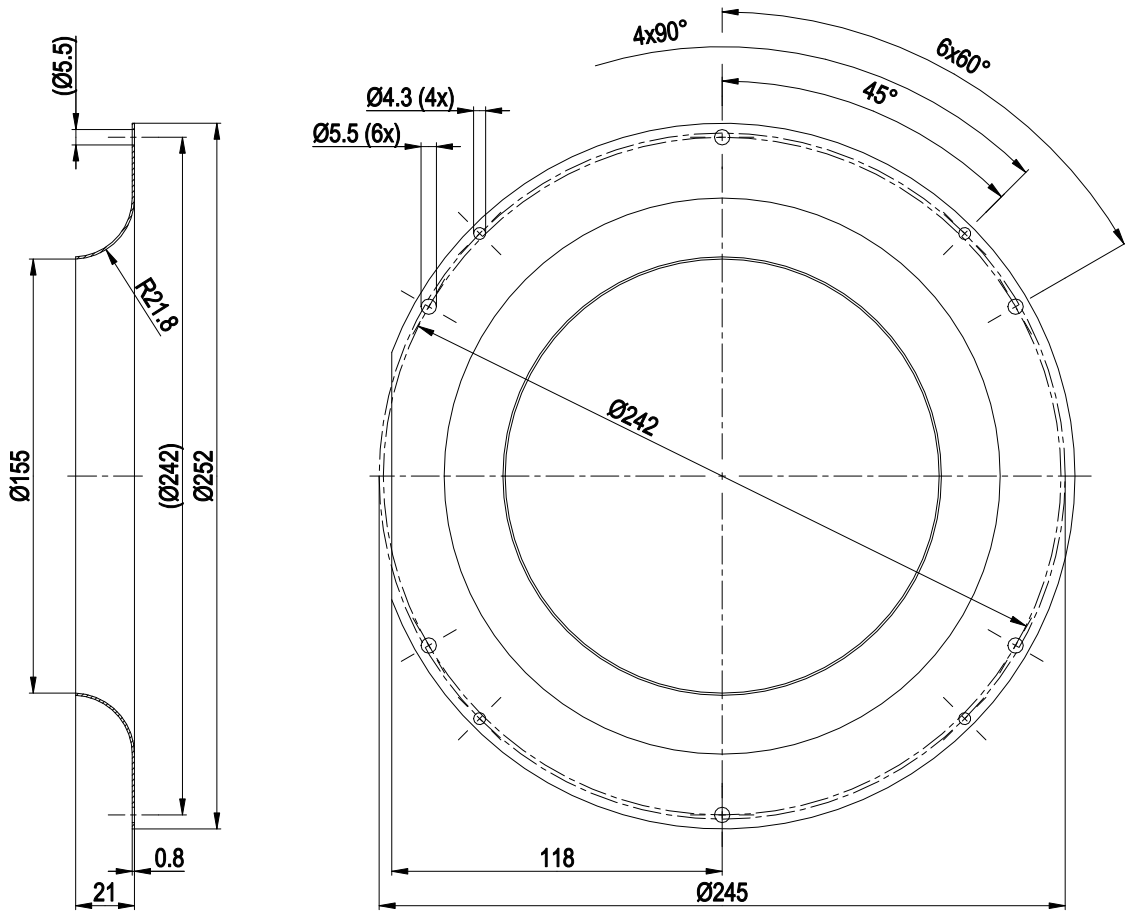

Inlet ring 09609-2-4013 not included in scope of delivery



Connection diagram

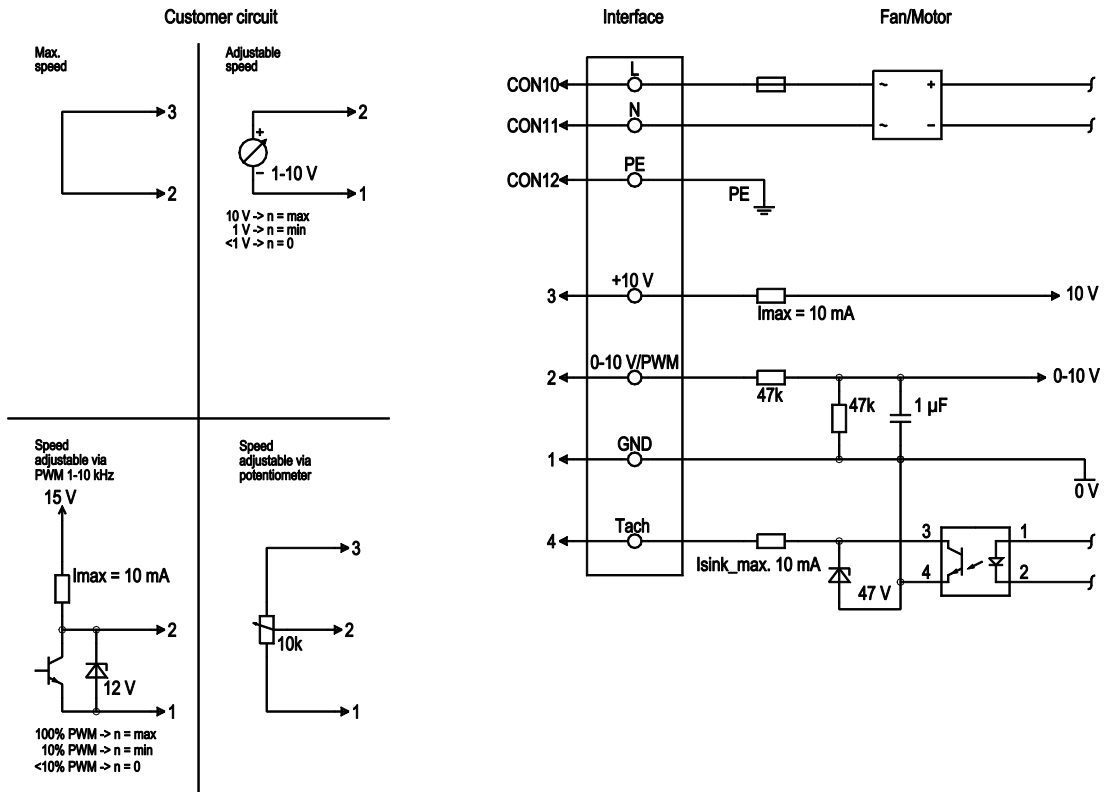

No.	Conn.	Designation	Color	Function/assignment
	CON10	L	black	Supply connection, power supply, phase, see nameplate for voltage range
	CON11	N	blue	Supply connection, power supply, neutral conductor, see nameplate for voltage range
	CON12	PE	green/yellow	Ground connection
	2	0- 10V PWM	yellow	0-10 V / PWM control input, $R_i=100 \text{ k}\Omega$, SELV
	4	Tach	white	Tach output, open collector, 1 pulse per revolution, $I_{sink \text{ max}} = 10 \text{ mA}$, SELV
	3	+10 V	red	Fixed voltage output 10 VDC $\pm 3 \%$, $I_{max} = 10 \text{ mA}$, short-circuit-proof, power supply for ext. devices (e.g. pot), SELV
	1	GND	blue	Reference ground for control interface, SELV



Curves: Air performance 50 Hz

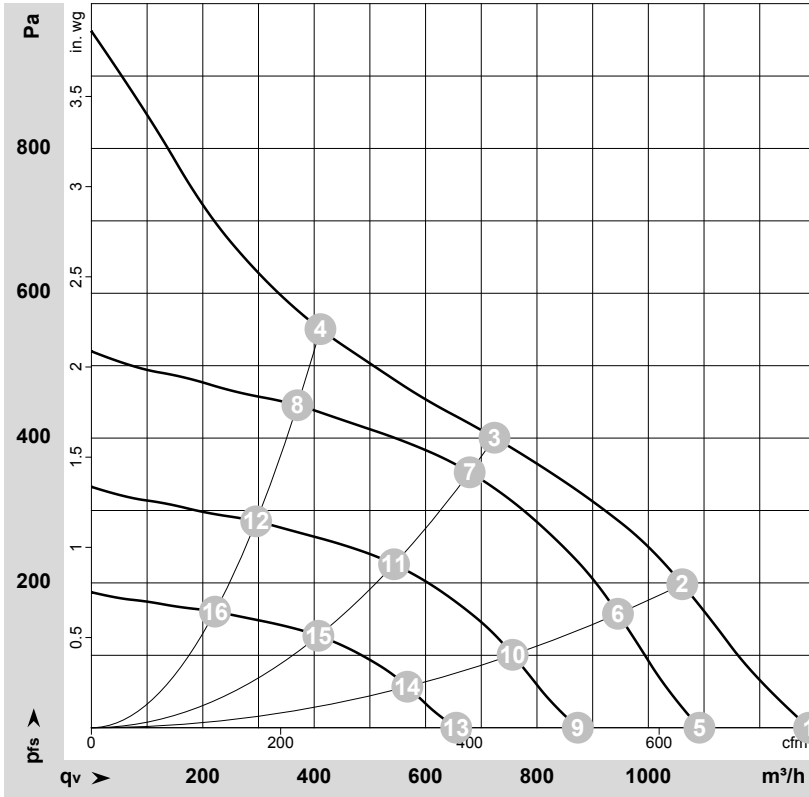

$\rho = 1.15 \text{ kg/m}^3 \pm 2 \%$

Measurement: LU-153697-1

Air performance measured according to ISO 5801 installation category A. For detailed information on the measurement setup, contact ebmpapst. Intake sound level: Sound power level according to ISO 13347 / sound pressure level measured at 1 m distance from fan axis. The values given are valid under the specified measuring conditions and may vary due to conditions of installation. For deviations from the standard configuration, the parameters have to be checked on the installed unit.

Measured values

	Wired	U	f	n	P _{ed}	I	LpA _{in}	LwA _{in}	q _v	P _{fs}	q _v	P _{fs}
		V	Hz	min ⁻¹	W	A	dB(A)	dB(A)	m ³ /h	Pa	cfm	in. wg
1	1~	230	50	3540	168	1.40	70	78	1290	0	760	0.00
2	1~	230	50	3365	168	1.40	65	73	1060	200	625	0.80
3	1~	230	50	3230	168	1.40	62	70	725	400	425	1.61
4	1~	230	50	3330	168	1.40	66	74	410	550	240	2.21
5	1~	230	50	3000	99	0.82	66	73	1090	0	645	0.00
6	1~	230	50	3000	116	0.96	62	70	945	157	555	0.63
7	1~	230	50	3000	135	1.12	61	68	680	353	400	1.42
8	1~	230	50	3000	119	0.99	63	71	370	446	220	1.79
9	1~	230	50	2400	51	0.42	60	68	875	0	515	0.00
10	1~	230	50	2400	59	0.49	57	64	755	101	445	0.41
11	1~	230	50	2400	69	0.58	55	63	545	226	320	0.91
12	1~	230	50	2400	61	0.51	57	65	295	286	175	1.15
13	1~	230	50	1800	21	0.18	53	61	655	0	385	0.00
14	1~	230	50	1800	25	0.21	49	57	565	57	335	0.23
15	1~	230	50	1800	29	0.24	48	55	410	127	240	0.51
16	1~	230	50	1800	26	0.21	50	58	220	161	130	0.65

Wired = Wiring · U = Voltage · f = Frequency · n = Speed (rpm) · P_{ed} = Power consumption · I = Current draw · LpA_{in} = Sound pressure level intake side · LwA_{in} = Sound power level intake side
 q_v = Air flow · P_{fs} = Pressure increase

