

R3G220-AE50-01

EC centrifugal fan

backward-curved, single-intake



R3G220-AE50-01 ebmpapst Datasheet

sales@fansco.com

www.fansco.com

Limited partnership · Headquarters Mulfingen
Amtsgericht (court of registration) Stuttgart · HRA 590344

General partner Elektrobau Mulfingen GmbH · Headquarters Mulfingen
Amtsgericht (court of registration) Stuttgart · HRB 590142



Nominal data

Type	R3G220-AE50-01	
Motor	M3G074-CF	
Phase		1~
Nominal voltage	VAC	230
Nominal voltage range	VAC	200 .. 277
Frequency	Hz	50/60
Method of obtaining data		ml
Speed (rpm)	min ⁻¹	3560
Power consumption	W	150
Current draw	A	1.1
Min. ambient temperature	°C	-25
Max. ambient temperature	°C	60

ml = Max. load · me = Max. efficiency · fa = Free air · cs = Customer specification · ce = Customer equipment
Subject to change

Data according to ErP Directive

		Actual	Req. 2015			
01 Overall efficiency η_{es}	%	48.8	43.1	09 Power consumption P_{ed}	kW	0.16
02 Measurement category		A		09 Air flow q_v	m ³ /h	600
03 Efficiency category		Static		09 Pressure increase p_{fs}	Pa	427
04 Efficiency grade N		67.7	62	10 Speed (rpm) n	min ⁻¹	3320
05 Variable speed drive		Yes		11 Specific ratio*		1.00

Data obtained at optimum efficiency level.

The ErP data is determined using a motor-impeller combination in a standardized measurement setup.

* Specific ratio = $1 + p_{fs} / 100\,000\text{ Pa}$

LU-69105



Technical description

Weight	2.2 kg
Fan size	220 mm
Rotor surface	Thick-film passivated
Electronics housing material	Die-cast aluminum
Impeller material	PA66 plastic, glass-fiber reinforced
Number of blades	11
Direction of rotation	Clockwise, viewed toward rotor
Degree of protection	IP44; installation- and position-dependent
Insulation class	"B"
Moisture (F) / Environmental (H) protection class	F3-1
Max. permitted ambient temp. for motor (transport/storage)	+ 80 °C
Min. permitted ambient temp. for motor (transport/storage)	- 40 °C
Installation position	Shaft horizontal or rotor on top; rotor on bottom on request
Condensation drainage holes	None
Mode	S1
Motor bearing	Ball bearing
Technical features	<ul style="list-style-type: none"> - Output 10 VDC, max. 1.1 mA - Tach output - Motor current limitation - Soft start - Control input 0-10 VDC / PWM - Thermal overload protection for electronics/motor
EMC immunity to interference	According to EN 61000-6-2 (industrial environment)
EMC circuit feedback	According to EN 61000-3-2/3
EMC interference emission	According to EN 61000-6-3 (household environment)
Touch current according to IEC 60990 (measuring circuit Fig. 4, TN system)	<= 3.5 mA
Motor protection	Thermal overload protector (TOP) internally connected
With cable	Variable
Protection class	I (with customer connection of protective earth)
Conformity with standards	EN 60335-1; CE
Approval	CCC; UL 2111; CSA C22.2 No. 77

Product drawing

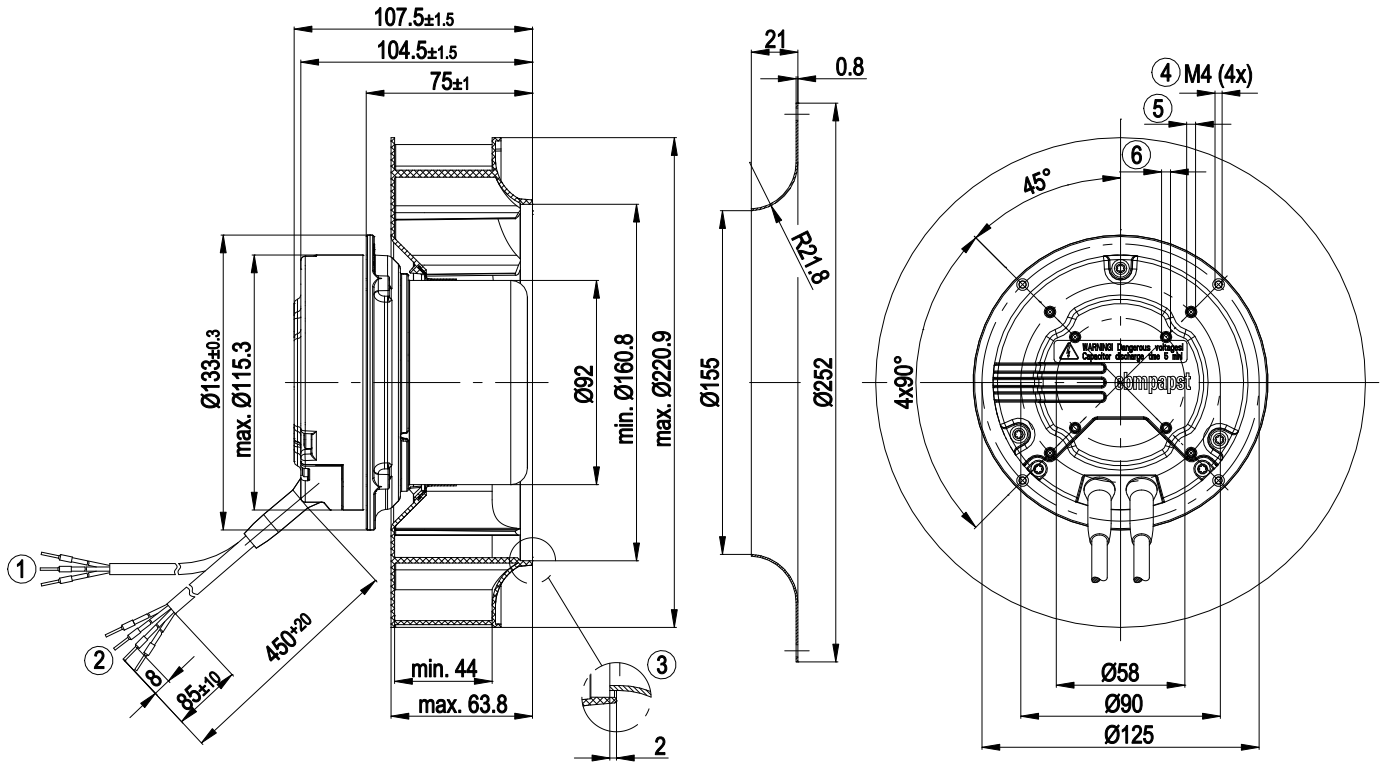

1	Cable AWG18, 3 x crimped ferrules
2	Cable AWG22, 4 x crimped ferrules
3	Accessory part: inlet ring 09609-2-4013 not included in scope of delivery
4	Clearance for screw 8-10 mm; tightening torque 2.5±0.2 Nm; gluing the screws is recommended
5	Tapping hole ready for self-tapping M4 screw, max. clearance for screw 6 mm
6	Tapping hole ready for self-tapping M4 screw, max. clearance for screw 8 mm



Connection diagram

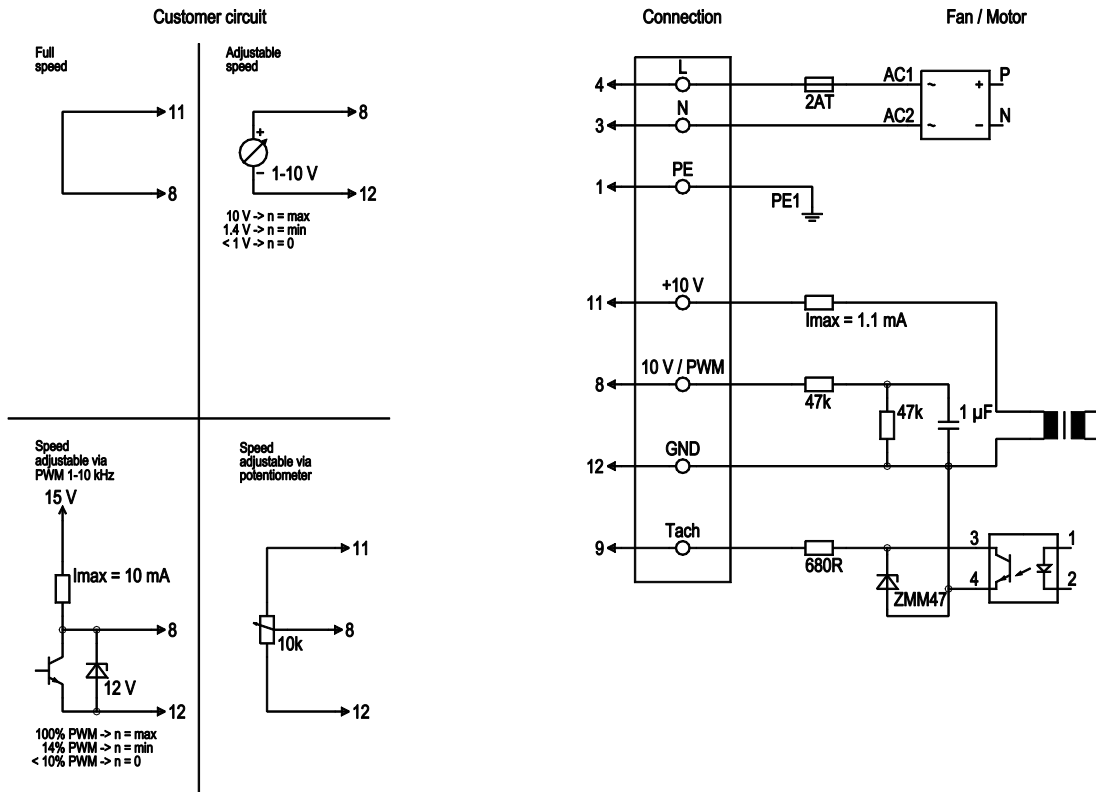

No.	Conn.	Designation	Color	Function/assignment
	4	L	black	Power supply 230 VAC, 50-60 Hz, see nameplate for voltage range
	3	N	blue	Neutral conductor
	1	PE	green/yellow	Protective earth
	8	0-10 V PWM	yellow	Control input 0-10 V or PWM, electrically isolated
	9	Tach	white	Tach output: open collector, 1 pulse per revolution, electrically isolated
	11	10V / max 1.1 mA	red	Voltage output 10 V/max. 1.1 mA, electrically isolated
	12	GND	blue	GND connection for control interface



Curves: Air performance 50 Hz

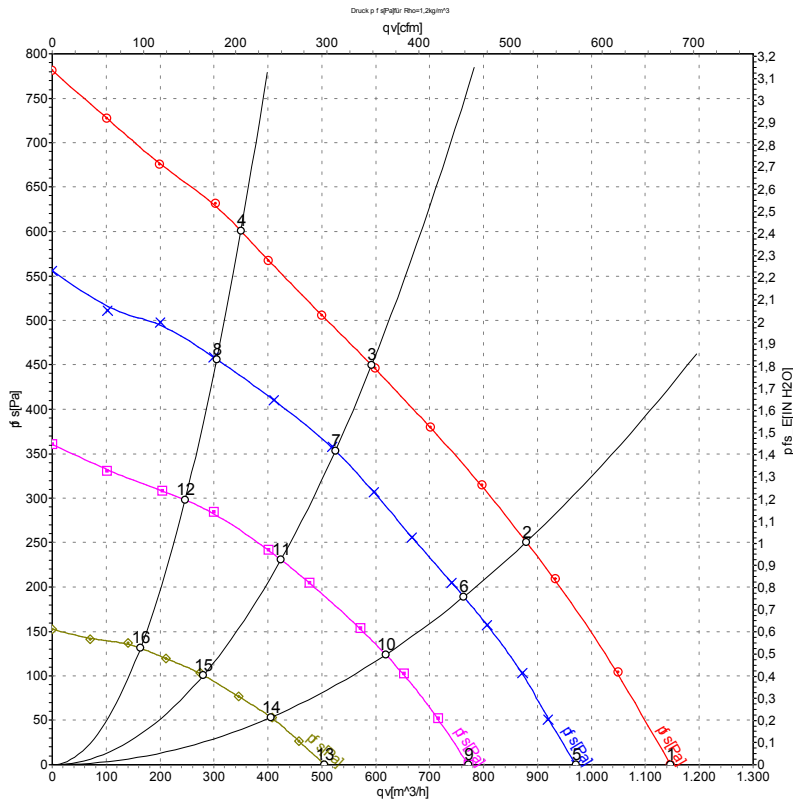

Measurement: LU-69105-1
 Measurement: LU-67052-1
 Measurement: LU-67053-1
 Measurement: LU-67054-1

Air performance measured according to ISO 5801 installation category A. For detailed information on the measurement setup, contact ebmpapst. Intake sound level: Sound power level according to ISO 13347 / sound pressure level measured at 1 m distance from fan axis. The values given are valid under the specified measuring conditions and may vary due to conditions of installation. For deviations from the standard configuration, the parameters have to be checked on the installed unit.

Measured values

	U	f	n	P _{ed}	I	qv	p _{fs}	qv	p _{fs}
	V	Hz	min ⁻¹	W	A	m ³ /h	Pa	CFM	inH2O
1	230	50	3560	150	1.10	1145	0	675	0.00
2	230	50	3410	170	1.26	880	250	520	1.00
3	230	50	3320	170	1.21	590	450	350	1.81
4	230	50	3455	170	1.25	350	600	205	2.41
5	230	50	3080	103	0.76	970	0	570	0.00
6	230	50	3015	120	0.88	765	189	450	0.76
7	230	50	3000	124	0.91	525	355	310	1.43
8	230	50	3040	115	0.86	305	457	180	1.83
9	230	50	2500	62	0.46	770	0	455	0.00
10	230	50	2430	67	0.50	620	124	365	0.50
11	230	50	2430	70	0.52	425	231	250	0.93
12	230	50	2455	69	0.51	245	298	145	1.20
13	230	50	1625	22	0.19	505	0	295	0.00
14	230	50	1595	24	0.20	405	54	240	0.22
15	230	50	1595	26	0.21	280	101	165	0.41
16	230	50	1605	23	0.19	165	131	95	0.53

U = Power supply · f = Frequency · n = Speed (rpm) · P_{ed} = Power consumption · I = Current draw · qv = Air flow · p_{fs} = Pressure increase

