

R3G210-AA73-12 ebmpapst Datasheet  
 sales@fansco.com  
 www.fansco.com

Limited partnership · Headquarters Muldingen  
 Amtsgericht (court of registration) Stuttgart · HRA 590344  
 General partner Elektrobau Muldingen GmbH · Headquarters Muldingen  
 Amtsgericht (court of registration) Stuttgart · HRB 590142

## Nominal data

Type	R3G210-AA73-12	
Motor	M3G074-CF	
Phase		1~
Nominal voltage	VAC	230
Frequency	Hz	50/60
Method of obtaining data		ml
Speed (rpm)	min <sup>-1</sup>	3050
Power consumption	W	176
Current draw	A	1.4
Min. ambient temperature	°C	-25
Max. ambient temperature	°C	50

ml = Max. load · me = Max. efficiency · fa = Free air · cs = Customer specification · ce = Customer equipment  
 Subject to change



### Technical description

Weight	4.8 kg
Size	210 mm
Motor size	74
Rotor surface	Thick-film passivated
Terminal box material	PA plastic
Impeller material	Sheet steel, rust-resistant
Number of blades	6
Direction of rotation	Counterclockwise, viewed toward rotor
Degree of protection	IP44; installation- and position-dependent as per EN 60034-5
Insulation class	"B"
Moisture (F) / Environmental (H) protection class	H1
Max. permitted ambient temp. for motor (transport/storage)	+ 80 °C
Min. permitted ambient temp. for motor (transport/storage)	- 40 °C
Installation position	Shaft horizontal or rotor on bottom; rotor on top on request
Condensation drainage holes	On rotor side
Mode	S1
Motor bearing	Ball bearing; Hybrid bearing (balls of Si <sub>3</sub> N <sub>4</sub> )
Technical features	<ul style="list-style-type: none"> <li>- Output 10 VDC, max. 1.1 mA</li> <li>- Tach output</li> <li>- Power limiter</li> <li>- Motor current limitation</li> <li>- Soft start</li> <li>- Control input 0-5 VDC / PWM</li> <li>- Control interface with SELV potential safely disconnected from the mains</li> <li>- Thermal overload protection for motor</li> </ul>
Touch current according to IEC 60990 (measuring circuit Fig. 4, TN system)	<= 3.5 mA
Electrical hookup	Terminal box
Motor protection	Thermal overload protector (TOP) internally connected
With cable	Variable
Protection class	I (with customer connection of protective earth)
Conformity with standards	EN 60335-1; CE
Approval	CSA C22.2 No. 77 + CAN/CSA-E60730-1; UL 1004-7 + 60730-1



Product drawing

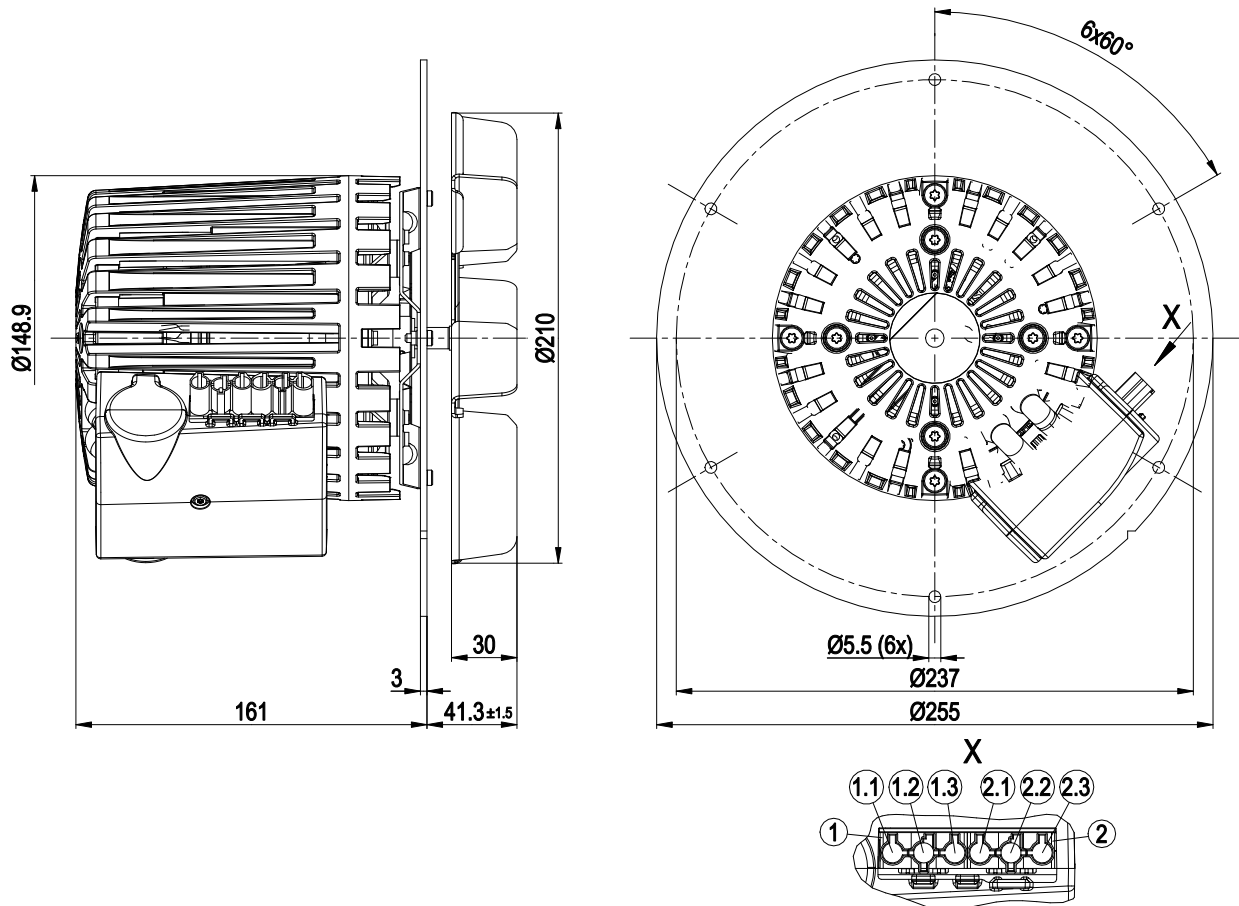

1	3-pole connector housing Wieland 92.032.3357.0
1.1	N (blue)
1.2	PE (green/yellow)
1.3	L (black)
2	3-pole connector housing Wieland 92.032.3757.0
2.1	GND (blue)
2.2	Tach (white)
2.3	0-5 V / PWM (yellow)



## Connection diagram

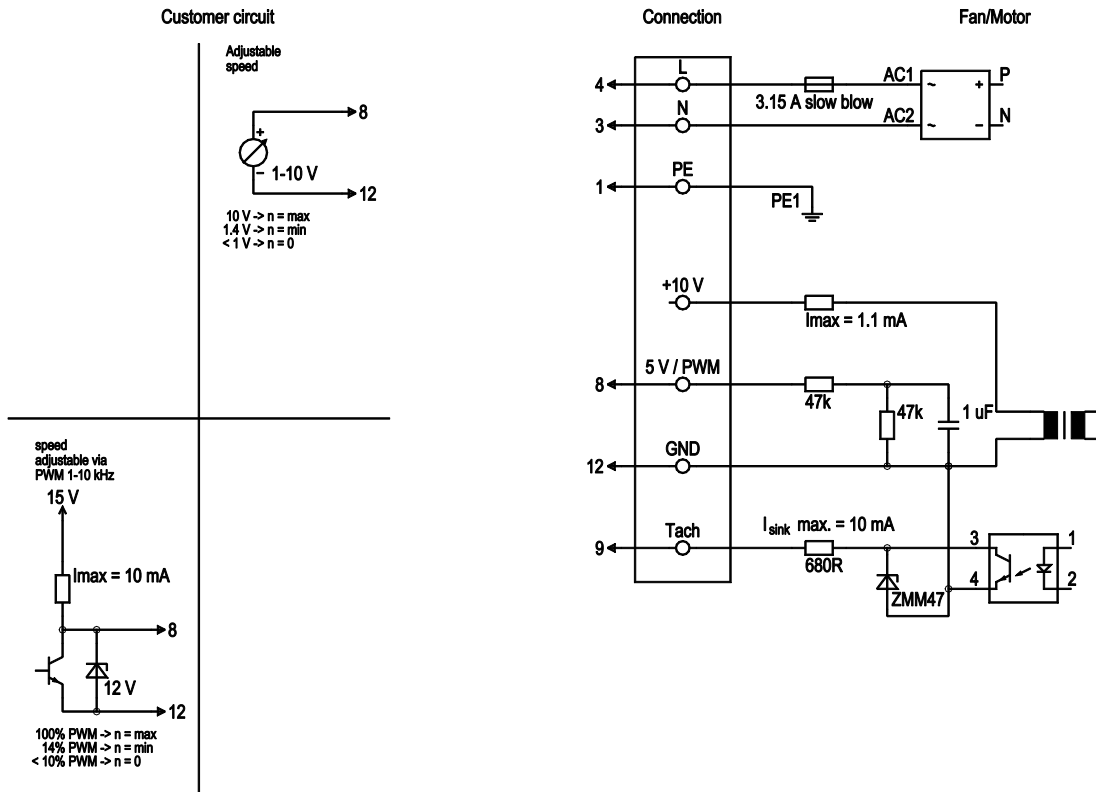

No.	Conn.	Designation	Color	Function/assignment
	4	L	black	Power supply 230 VAC, 50-60 Hz, see nameplate for voltage range
	3	N	blue	Neutral conductor
	1	PE	green/yellow	Protective earth
	8	0- 5 V / PWM	yellow	Control input 0-5 V or PWM, electrically isolated
	12	GND	blue	Control interface GND connection
	9	Tacho	white	Tach output: Open collector, 1 pulse per revolution, electrically isolated, I <sub>sink</sub> max = 10 mA



## Curves: Air performance 50 Hz

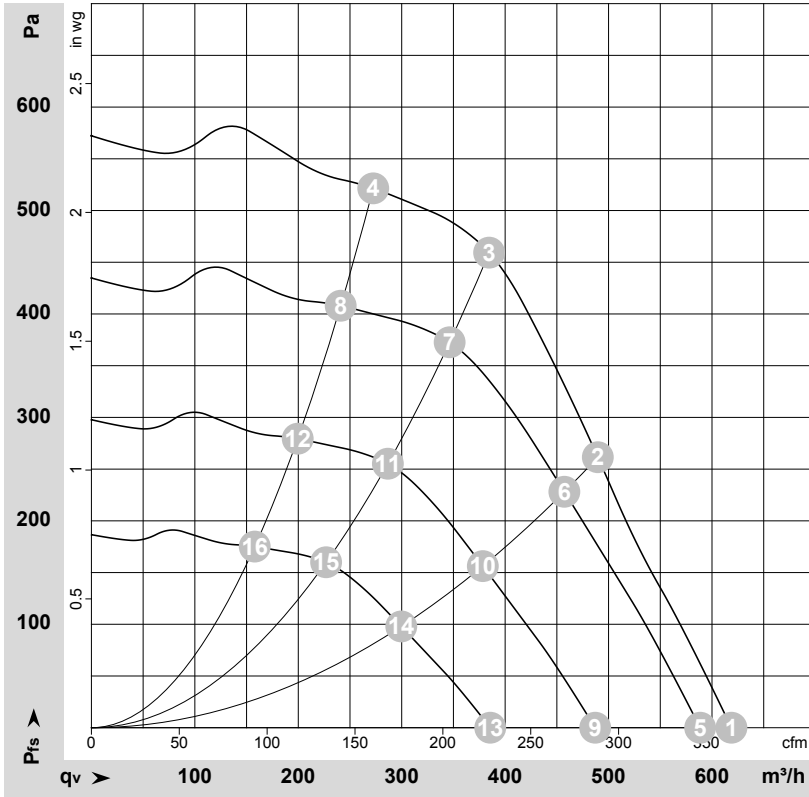

$\rho = 1.15 \text{ kg/m}^3 \pm 2 \%$

Measurement: LU-166312-1

Air performance measured according to ISO 5801 installation category A. For detailed information on the measurement setup, contact ebmpapst. Intake sound level: Sound power level according to ISO 13347 / sound pressure level measured at 1 m distance from fan axis. The values given are valid under the specified measuring conditions and may vary due to conditions of installation. For deviations from the standard configuration, the parameters have to be checked on the installed unit.

## Measured values

	Wired	U	f	n	P <sub>ed</sub>	I	q <sub>v</sub>	P <sub>fs</sub>	q <sub>v</sub>	P <sub>fs</sub>
		V	Hz	min <sup>-1</sup>	W	A	m <sup>3</sup> /h	Pa	cfm	in. wg
1	Y	230	50	3050	176	1.40	620	0	365	0.00
2	Y	230	50	3105	176	1.40	490	260	290	1.04
3	Y	230	50	3220	164	1.33	385	460	225	1.85
4	Y	230	50	3280	145	1.19	270	520	160	2.09
5	Y	230	50	2900	152	1.21	590	0	345	0.00
6	Y	230	50	2900	143	1.15	455	228	270	0.92
7	Y	230	50	2900	120	0.97	345	374	205	1.50
8	Y	230	50	2900	100	0.82	240	408	140	1.64
9	Y	230	50	2400	86	0.69	485	0	285	0.00
10	Y	230	50	2400	81	0.65	380	156	220	0.63
11	Y	230	50	2400	68	0.55	285	256	170	1.03
12	Y	230	50	2400	57	0.47	200	280	115	1.12
13	Y	230	50	1900	43	0.34	385	0	225	0.00
14	Y	230	50	1900	40	0.32	300	98	175	0.39
15	Y	230	50	1900	34	0.27	225	160	135	0.64
16	Y	230	50	1900	28	0.23	160	175	95	0.70

Wired = Wiring · U = Voltage · f = Frequency · n = Speed (rpm) · P<sub>ed</sub> = Power consumption · I = Current draw · q<sub>v</sub> = Air flow · p<sub>fs</sub> = Pressure increase

